

REV	DATE	BY	DESCRIPTION
A	25-6-2015	CR	KNOB ADDED FOR SECURING FRONT PLATE ON GRID
B	30-6-2017	AvD	ITEM 1 (INSERT PLATE) CHANGED
C	3-3-2022	AvD	E0028964 AND 70.4200006 MOVED TO UNDERLYING DRAWING, TYPE PLATE ADDED, MATERIAL CHANGED INTO AISI316L, PRODUCT KEY CORRECTED.

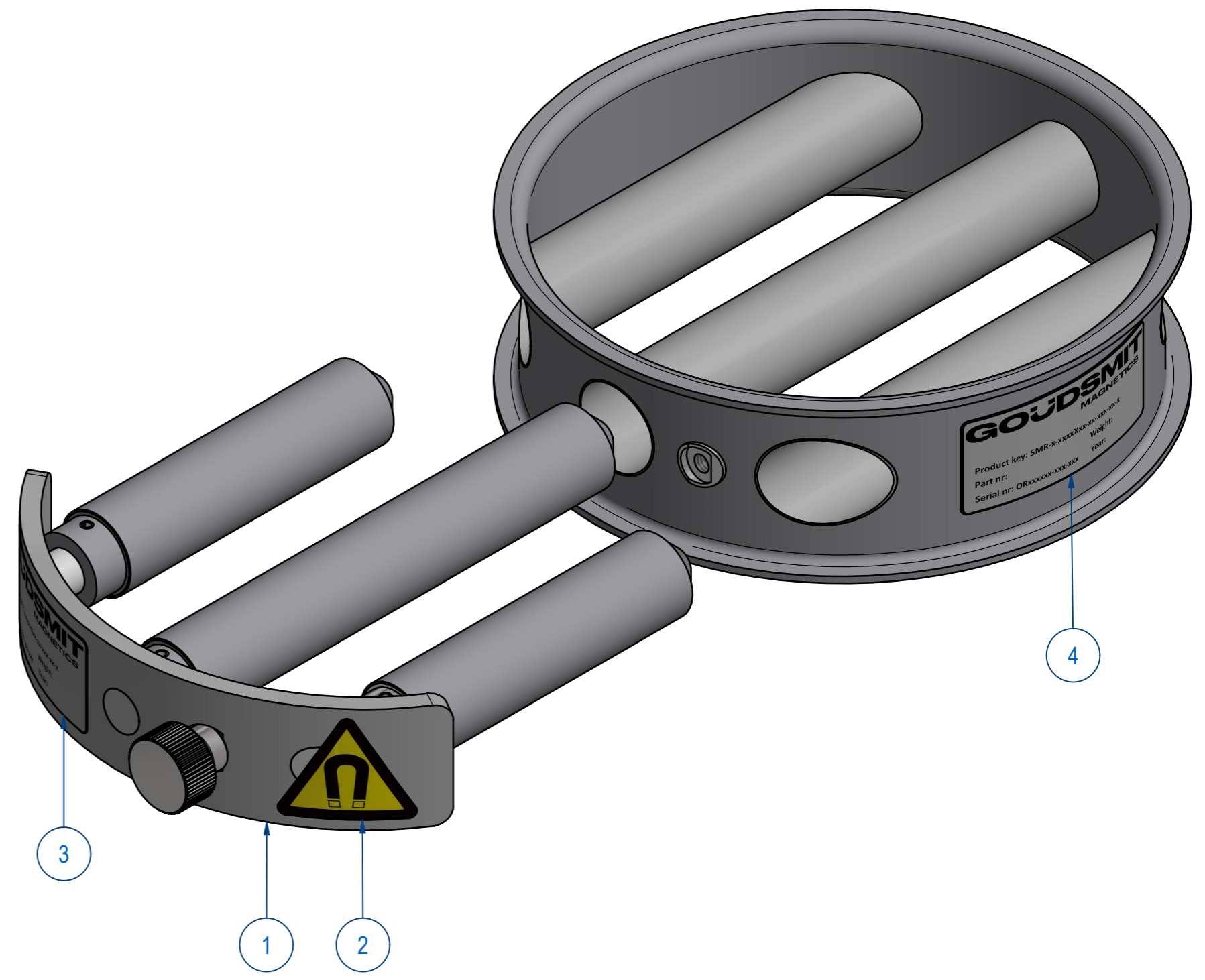
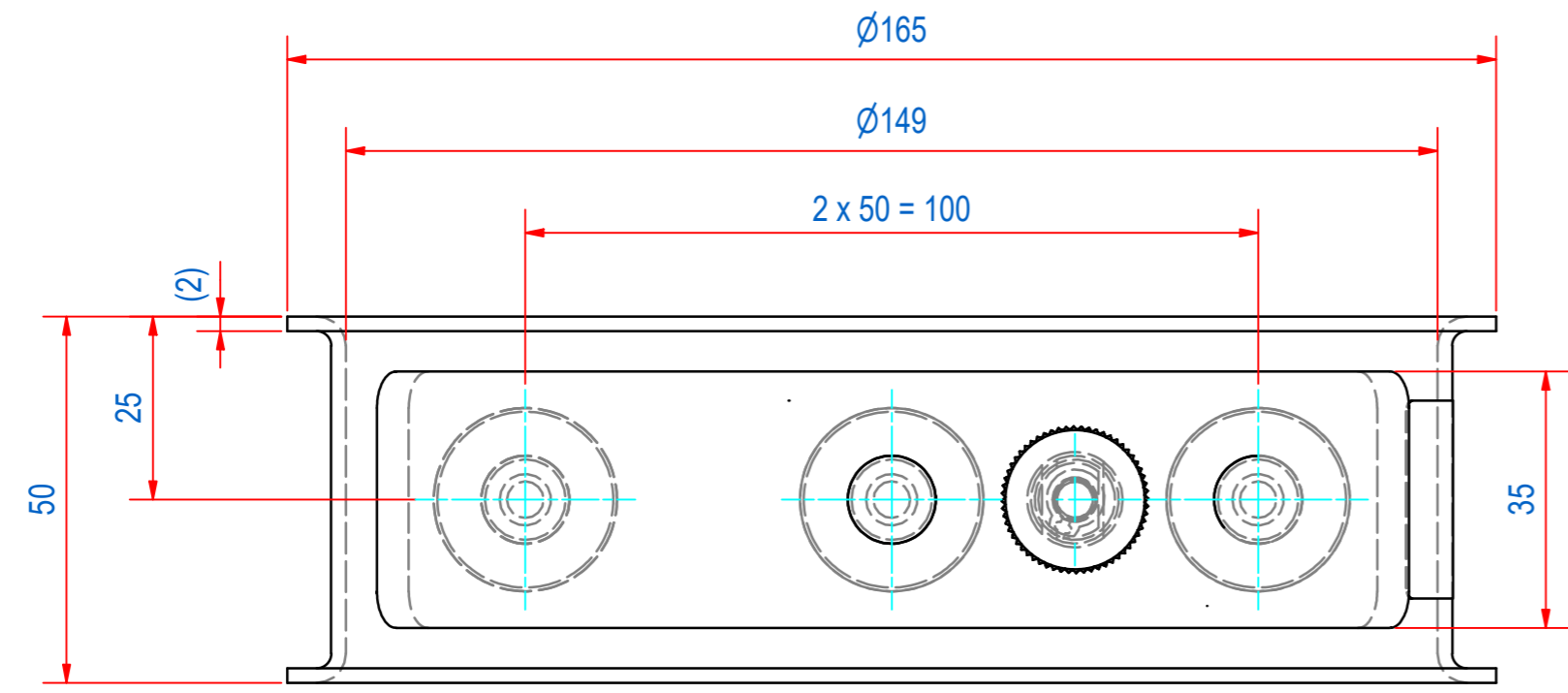
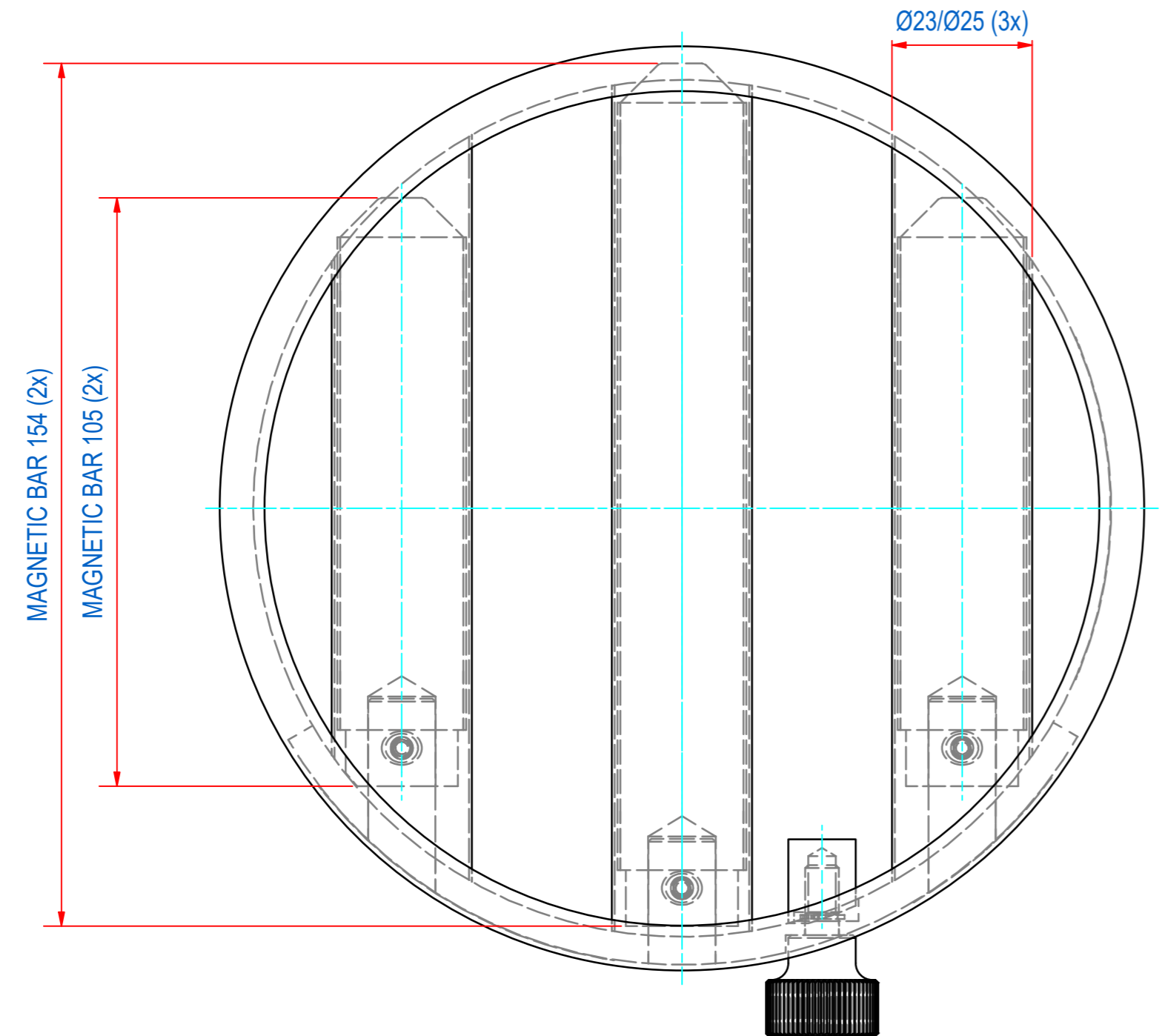

ITEM	QTY	PART NUMBER	DESCRIPTION	Dimensions
4	1	E0150254	TYPE PLATE SMR-JF-D150-HOUSE	
3	1	E0150253	TYPE PLATE SMR-JF-D150-INSERT	
2	1	E0150278	STICKER MAGN FIELD 30MM SMR-JF-D150	
1	1	A110026	SMR-N-D150x50-JF-03E GRID ASSY	

RAW MAT.	Quantity	Material Number	Material Description	Length (mm)	Width (mm)
	1				

Sheet:	A2	Extra info:	MAGNETIC GRID	General tolerance:	ISO 2768- mK
Drawn:	CR	Weight (kg):	1,9	Drawn according:	ISO286; ISO1101; ISO2553
Date:	31-7-2014	Status:	Standard	Customer reference number:	
Spare part:	False	Source:	MC-C	Document number:	SEMR015078
Quick search:	MRNB0150	Description:	SMR-N-D150x50-JF-03E-S6-S	Doc.Rev:	C
				Part number:	SEMR015078
				Rev:	C