

REV	DATE	BY	DESCRIPTION
-	3-6-2013	CR	NEW REVISION VAULT, NOTHING CHANGED, OLD REV WAS B
A	26-2-2015	CR	KNOB ADDED FOR SECURING GRONT PLATE ON GRID
B	3-3-2022	AvD	E0028964 AND 70.4200006 MOVED TO UNDERLYING DRAWING, TYPE PLATE ADDED, MATERIAL CHANGED INTO AISI316L, PRODUCT KEY CORRECTED.

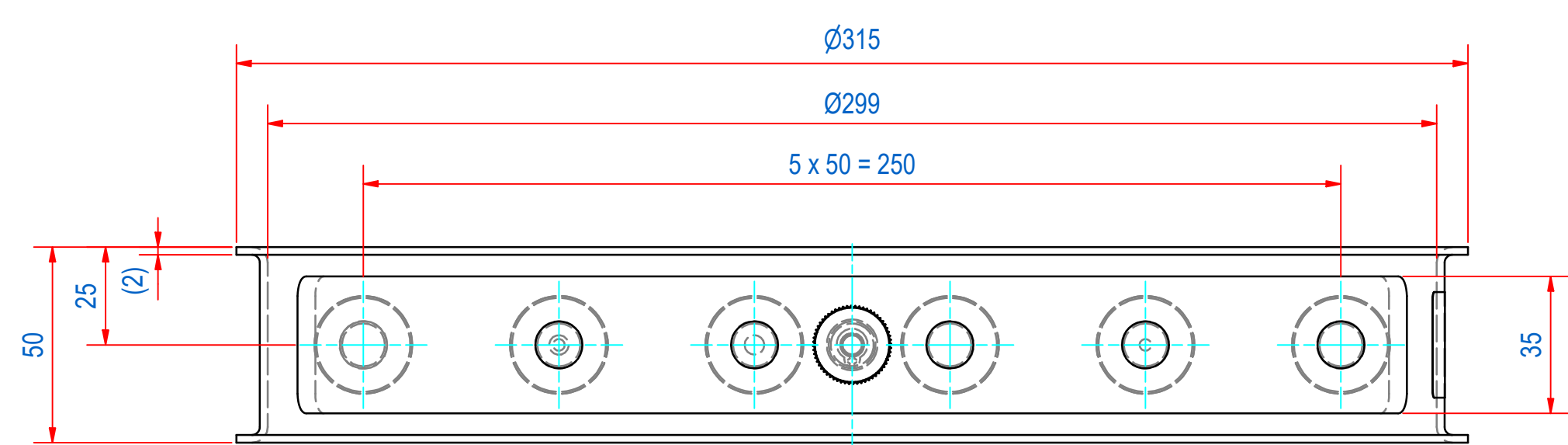
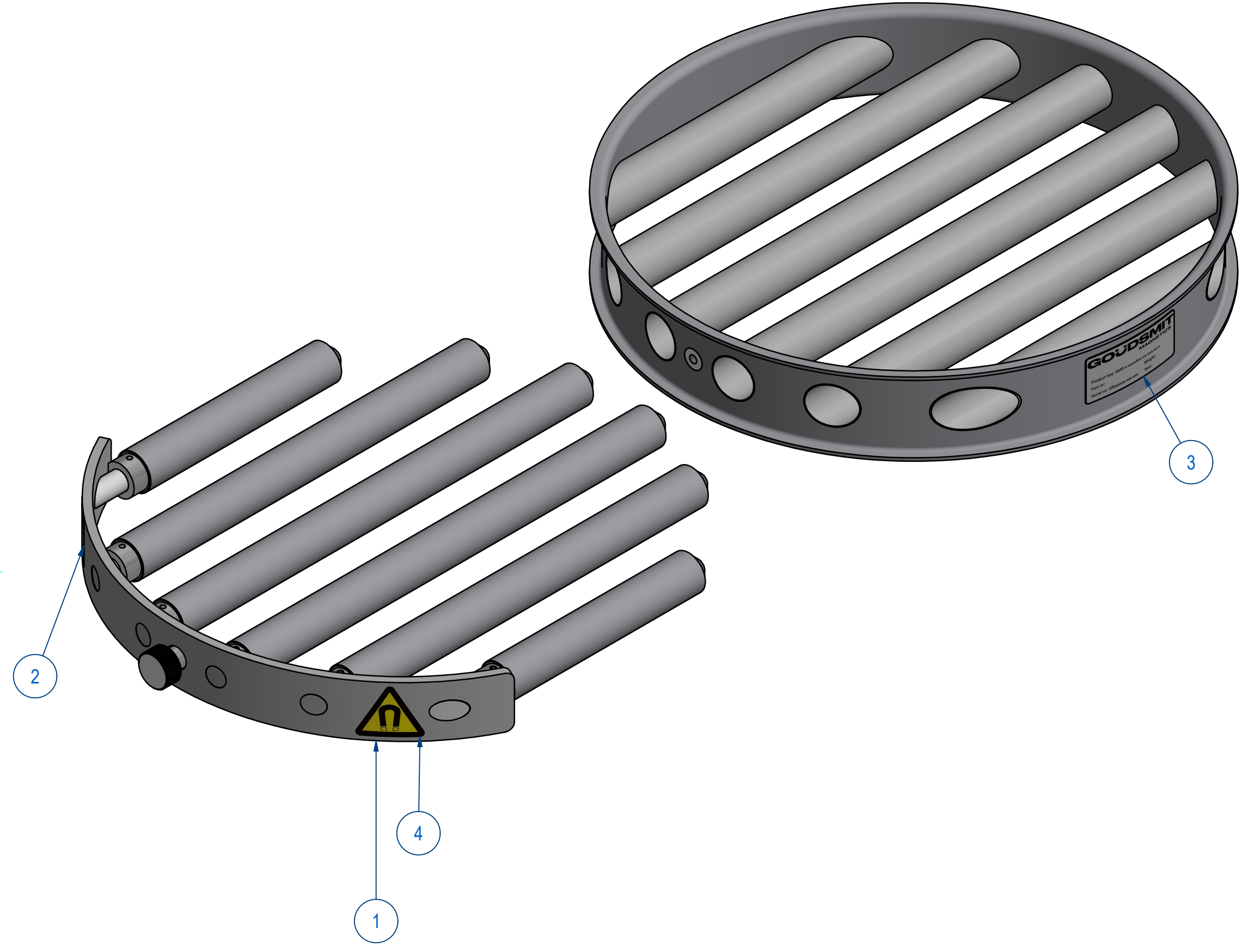
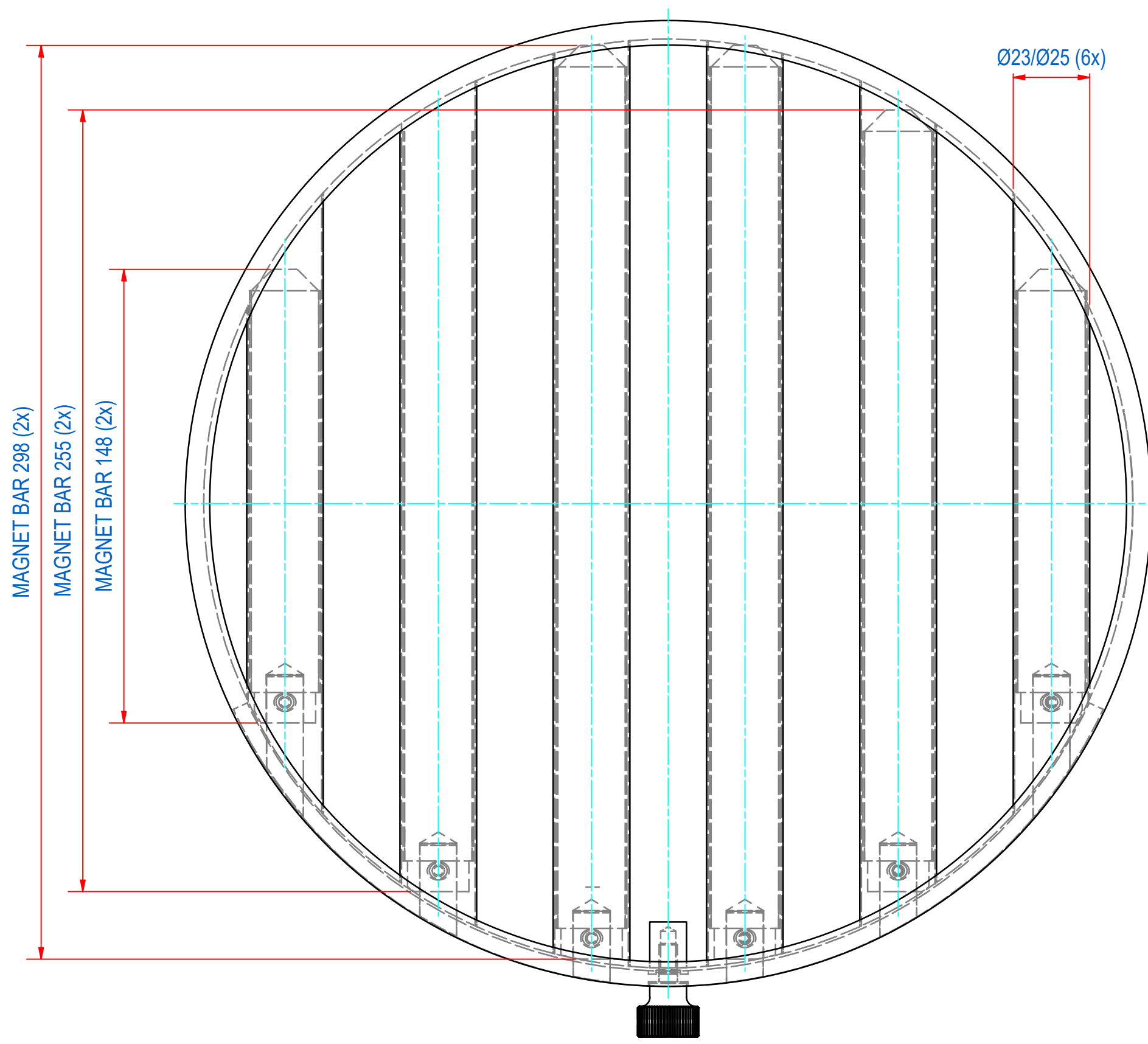

ITEM	QTY	PART NUMBER	DESCRIPTION	Dimensions
4	1	E0150281	STICKER MAGN FIELD 30MM SMR-JF-D300	
3	1	E0150260	TYPE PLATE SMR-JF-D300-HOUSE	
2	1	E0150259	TYPE PLATE SMR-JF-D300-INSERT	
1	1	A250499	SMR-N-D300x50-JF-06E GRID ASSY	

RAW MAT.	Quantity	Material Number	Material Description	Length (mm)	Width (mm)
	1				

Sheet:	A2	Extra info:	MAGNETIC GRID	General tolerance:	ISO 2768- mK
Drawn:	CR	Weight (kg):	6,1	Drawn according:	ISO286; ISO1101; ISO2553
Date:	16-4-2009	Status:	Standard	Customer reference number:	
Spare part:	False	Source:	MC-C	Document number:	SEMR030078
Quick search:	MRNB0300			Doc.Rev:	B
Description:	SMR-N-D300x50-JF-06E-S6-S			Part number:	SEMR030078
				Rev:	B