

REV	DATE	BY	DESCRIPTION
A	12-4-2018	CR	TYPE PLATE AND WARNING STICKERS ADDED
B	5-7-2018	CR	ITEM 5 ADDED
C	22-10-2020	CR	UNDERLYING DRAWING CHANGED

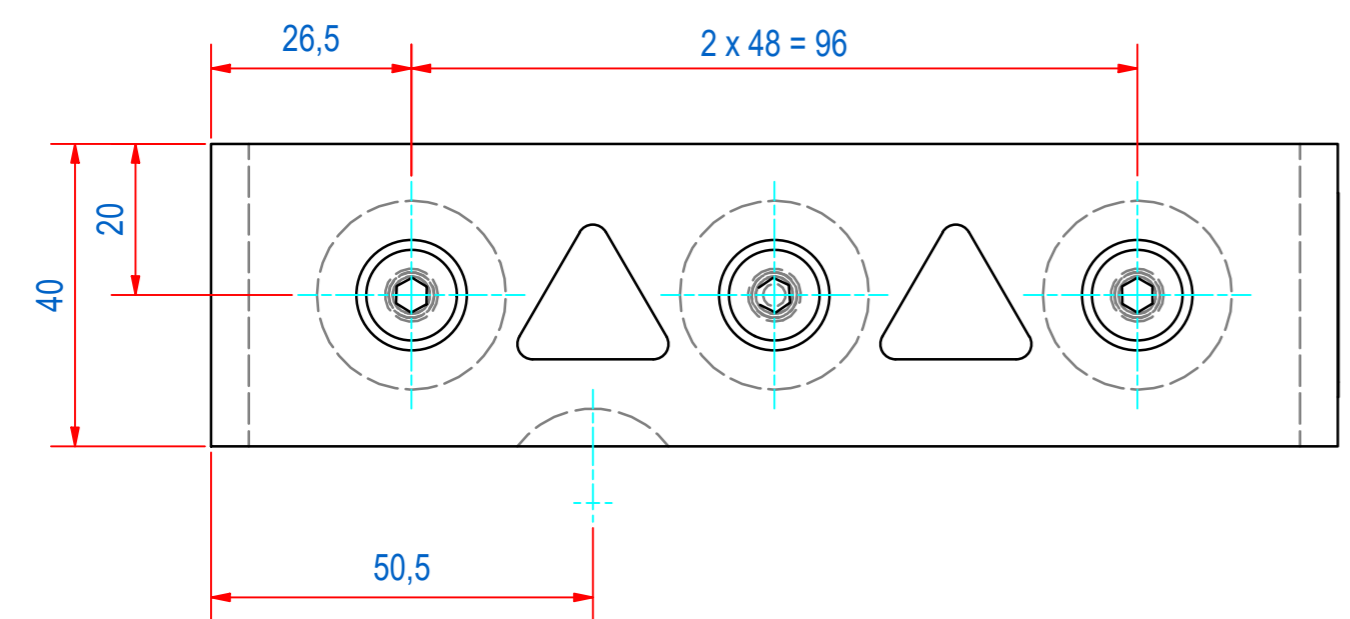
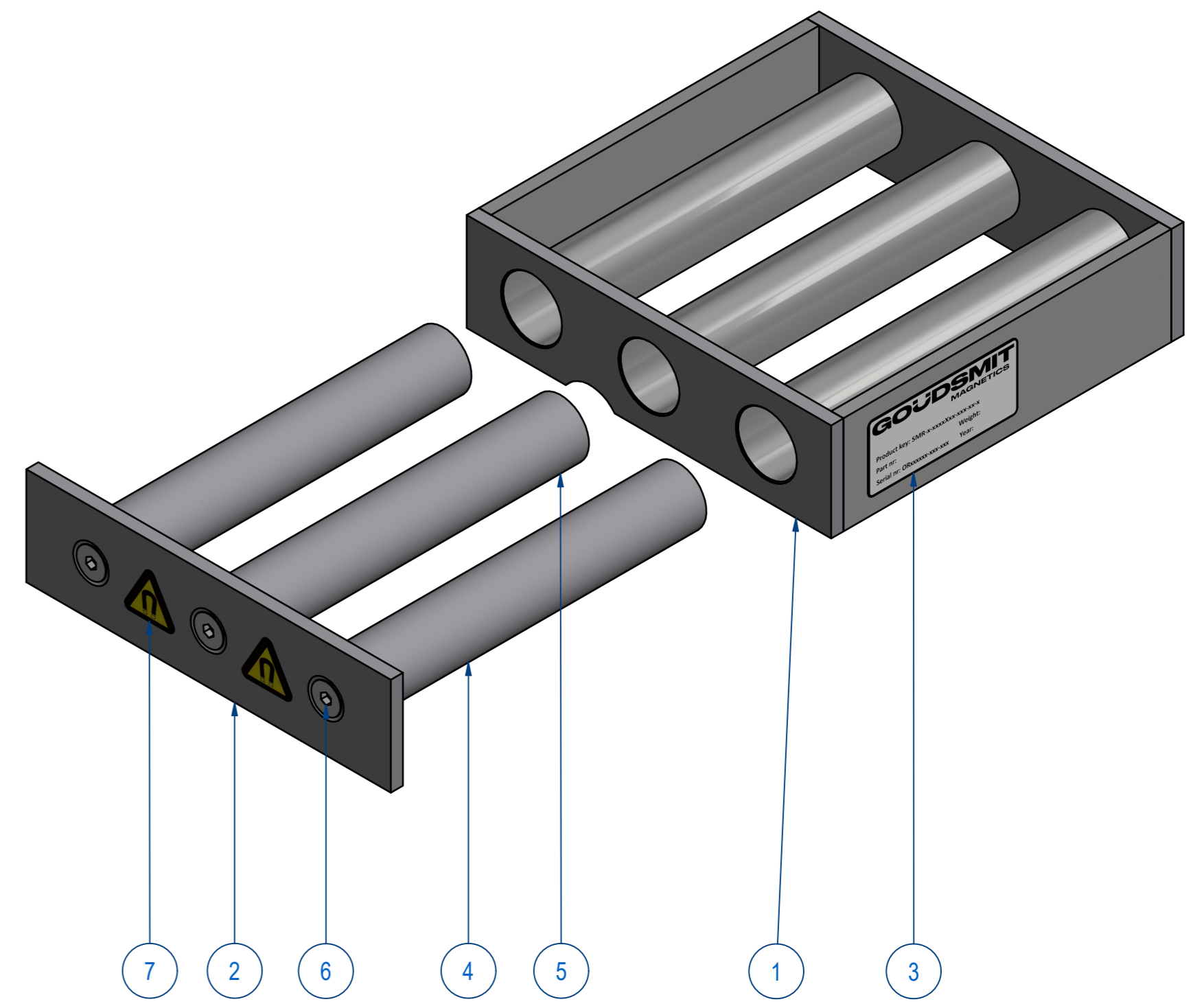
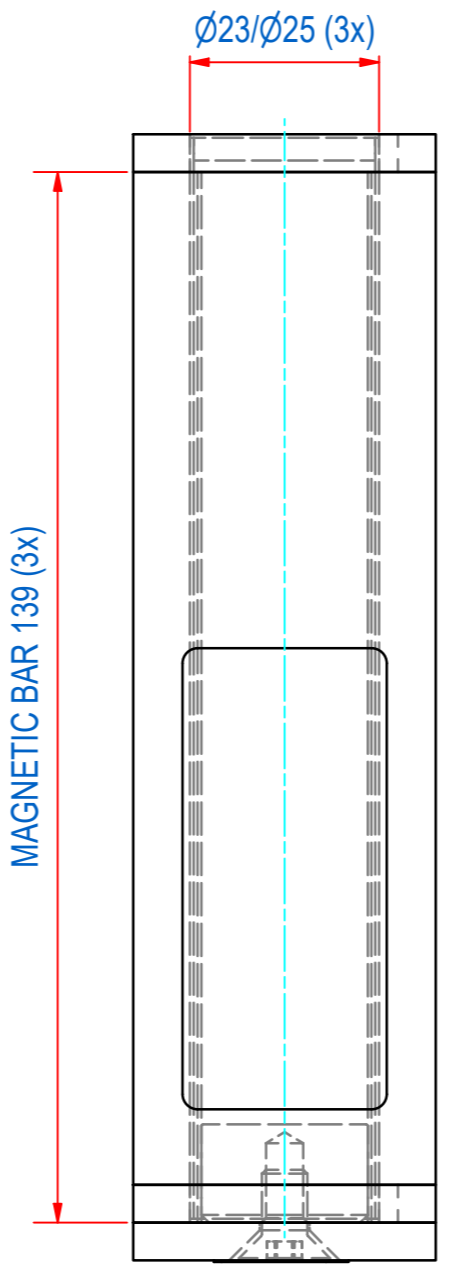
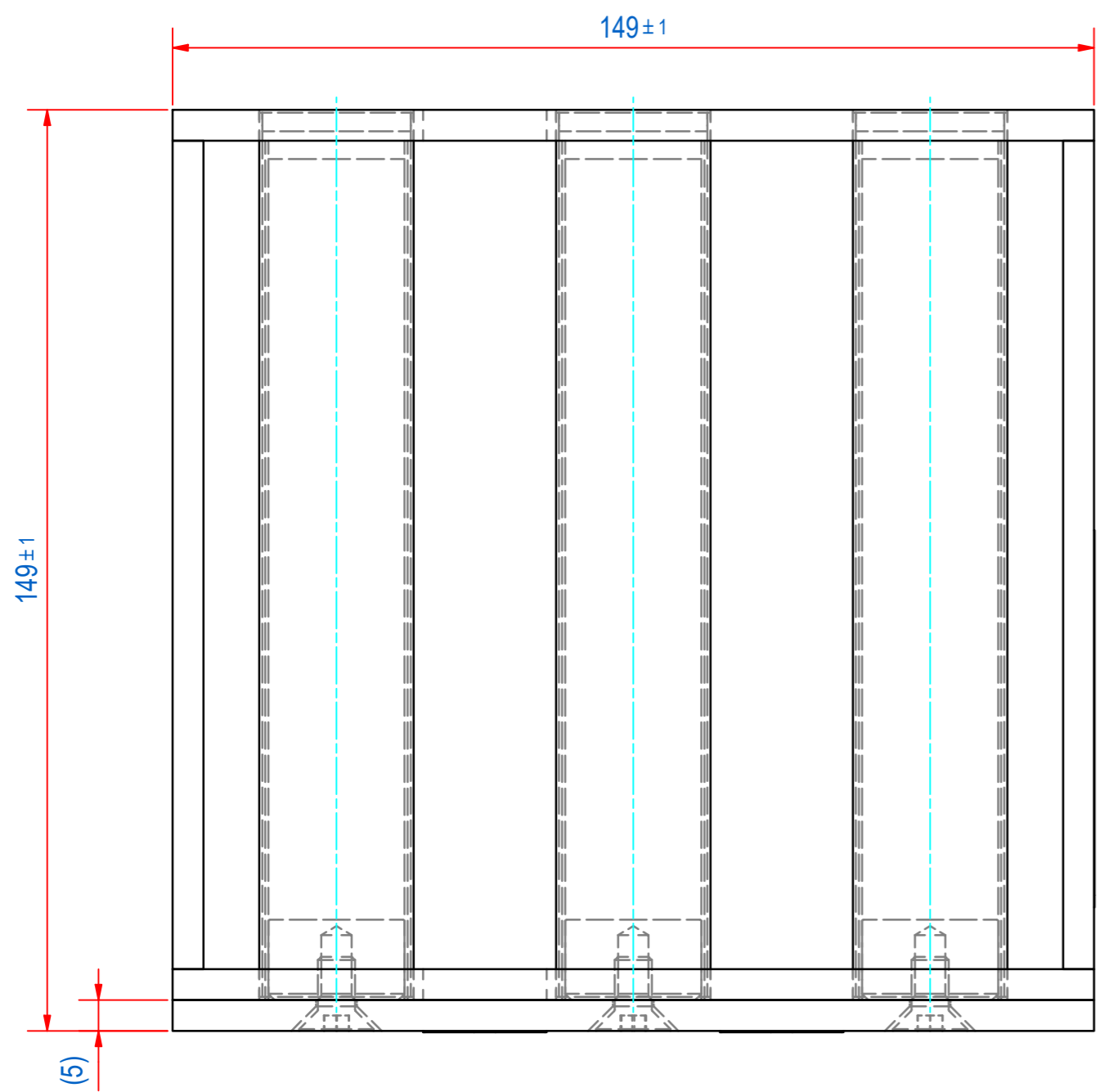

ITEM	QTY	PART NUMBER	DESCRIPTION	Dimensions
7	2	1000.20080	STICKER MAGNETIC FIELD 20mm	
6	3	52.0306012	SCREW, HEX S CS M6x12 - A4	M6x12
5	1	SBAMA100019-139	BAR-N-23-139-25-1M6-NH-B	
4	2	SBAMA100010-139	BAR-N-23-139-25-1M6-NW-B	
3	1	E0086577	TYPE PLATE SQUARE GRID SMR	
2	1	S240043	FRONT MAGNET STRIP 40x5 L149	
1	1	A240026	SMR-EXTRACTOR #149x40 3B 316L	

RAW MAT.	Quantity	Material Number	Material Description	Length (mm)	Width (mm)
	1				

Sheet: A2	Extra info: MAGNETIC GRID	General tolerance: ISO 2768 - mK
Drawn: CR	Weight (kg): 2,5	Drawn according: ISO286; ISO1101; ISO2553
Date: 27-8-2014		Status: Standard
Spare part: False	Source: MC-C	Customer reference number:
Quick search: MRNB1515		
Description: SMR-N-0150x150x40-03E-S6-B	Document number: SEMR151538	Doc.Rev: C
	Part number: SEMR151538	Rev: C