

REV	DATE	BY	DESCRIPTION
-	14-6-2013	CR	NEW REVISION VAULT, OLD REV WAS D - MAGNETIC BARS CHANGED: NdFeB WAS NdFeB HT
A	22-10-2020	CR	UNDERLYING DRAWING LASER WELDED, TYPE PLATE AND WARNING STICKERS ADDED

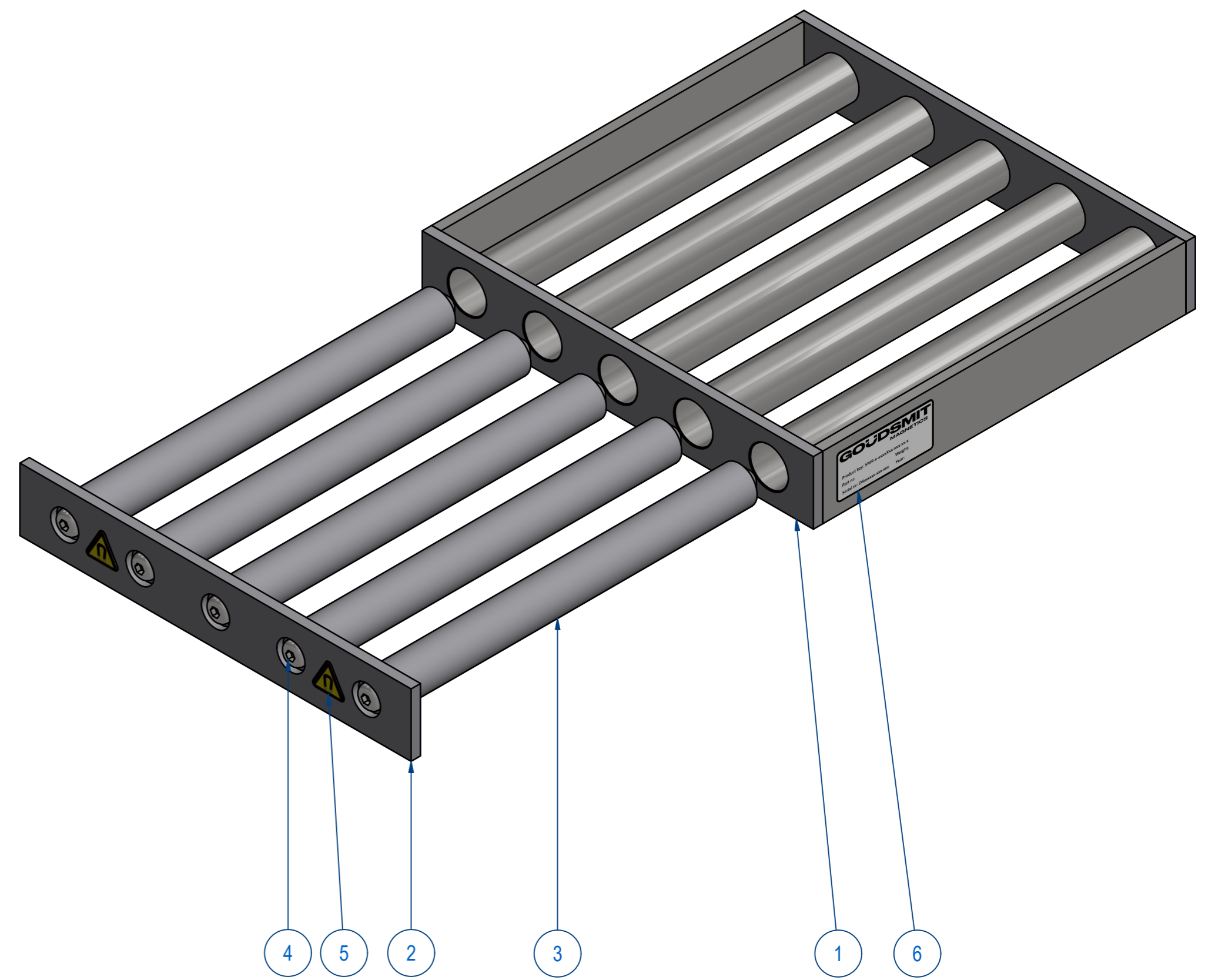
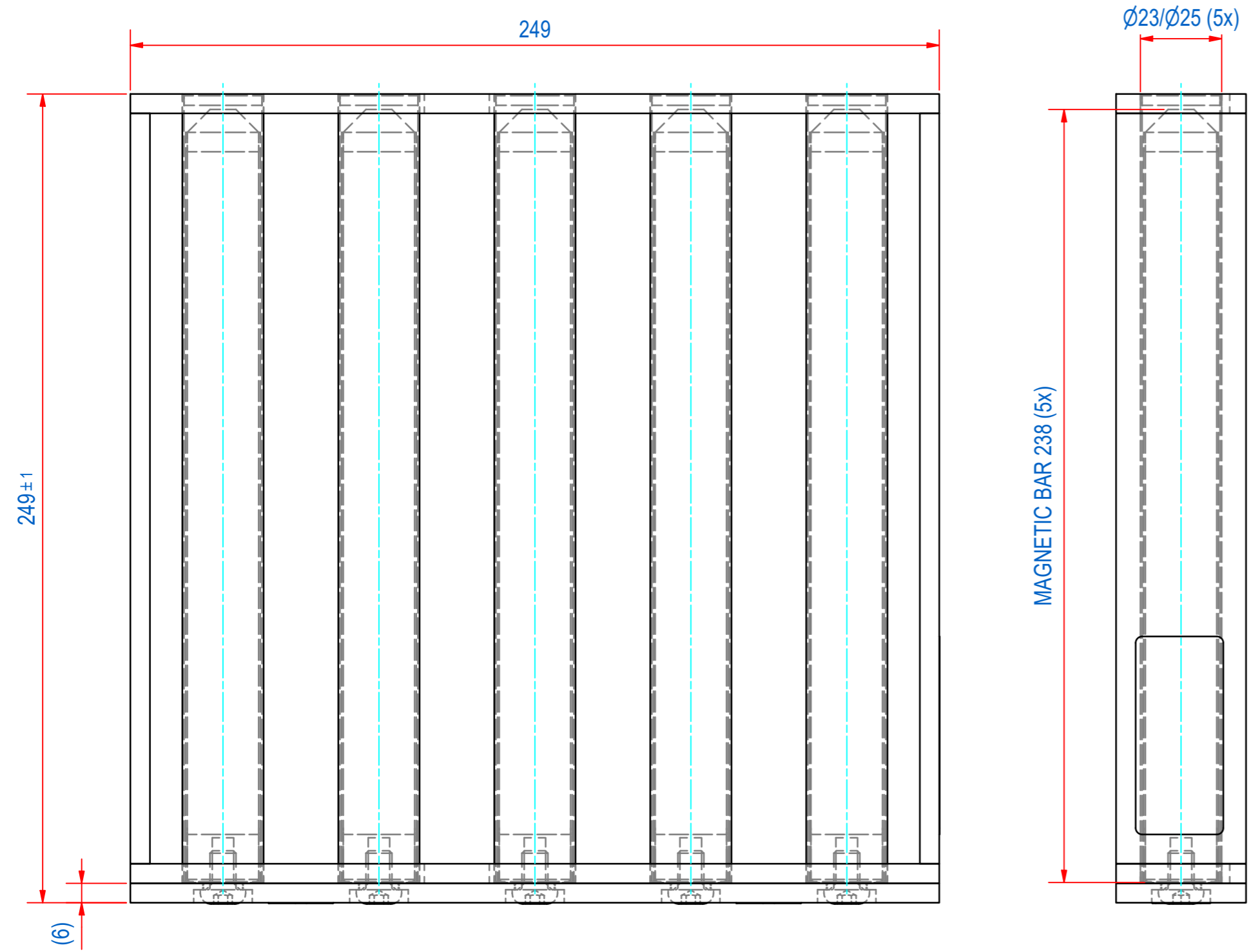

ITEM	QTY	PART NUMBER	DESCRIPTION	Dimensions
6	1	E0086577	TYPE PLATE SQUARE GRID SMR	
5	2	1000.20080	STICKER MAGNETIC FIELD 20mm	
4	5	54.1208012	SCREW, HEX S BH LOW M8x12-A2	
3	5	SBAMB100030-238	BAR-N-23-238-25-CM8-SH-B	
2	1	S240056	SMR-FRONT MAGNET STRIP 40x6 L249	
1	1	A240028	SMR-EXTRACTOR #149x40 5B 316L	

RAW MAT.	Quantity	Material Number	Material Description	Length (mm)	Width (mm)
	1				

Sheet:	A2	Extra info:	MAGNETIC GRID	General tolerance:	ISO 2768- mK
Drawn:	JM	Weight (kg):	6,2	Drawn according:	ISO286; ISO1101; ISO2553
Date:	29-10-1995	Status:	Standard	Customer reference number:	
Spare part:	False	Source:	MC-C	Document number:	SEMR252538
Quick search:	MRNB2525	Description:	SMR-N-0250x250x40-05E-S6-B	Doc.Rev:	A
				Part number:	SEMR252538
				Rev:	A



© All rights reserved. Reproduction is not permitted without written permission of GOUDSMIT Magnetic Systems BV