

REV	DATE	BY	DESCRIPTION
-	14-5-2013	CR	ORIGINAL INVENTOR DRAWING
A	6-1-2014	AvD	NAME PLATE ADDED, TYPE PLATE CHANGED

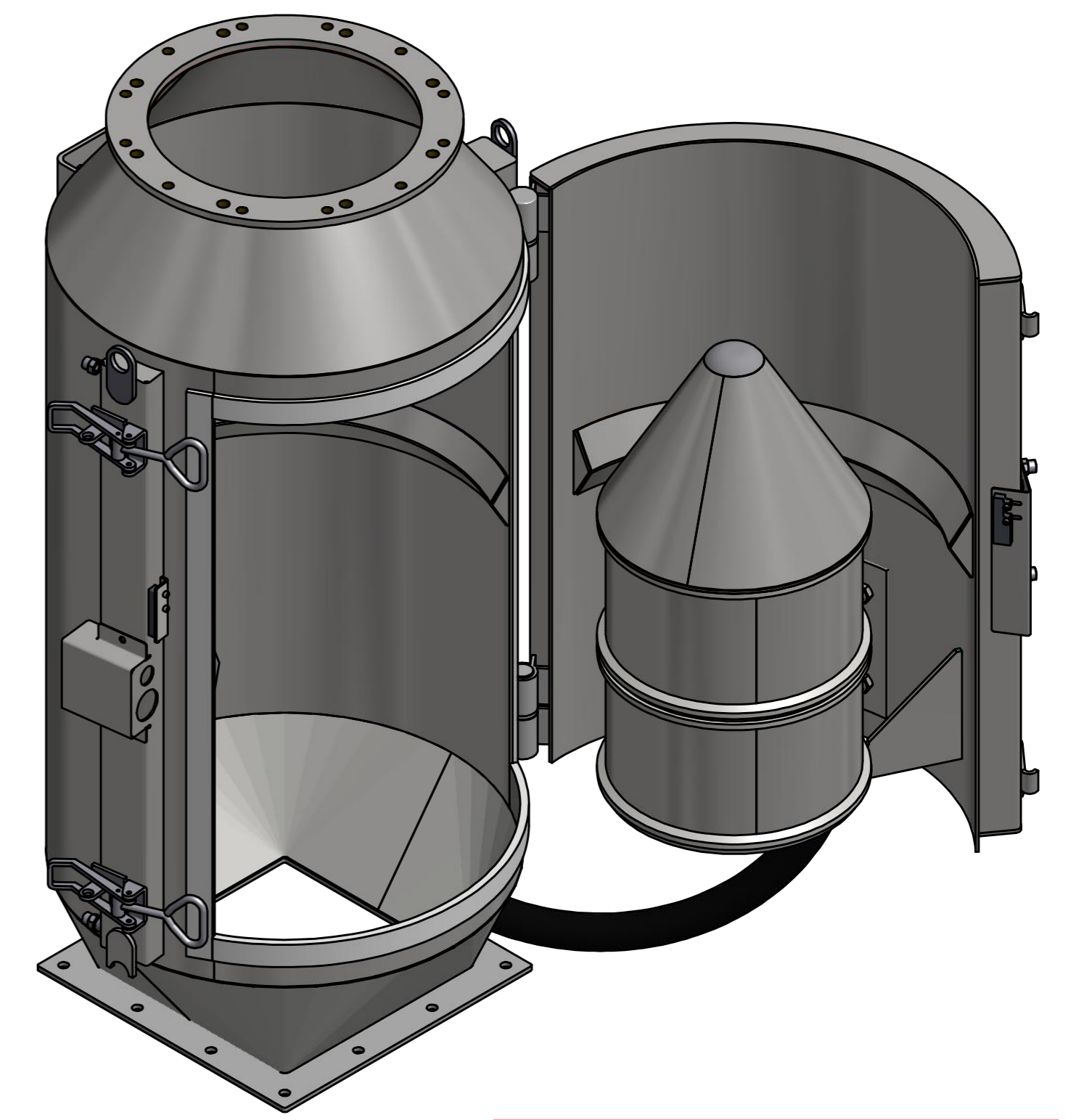
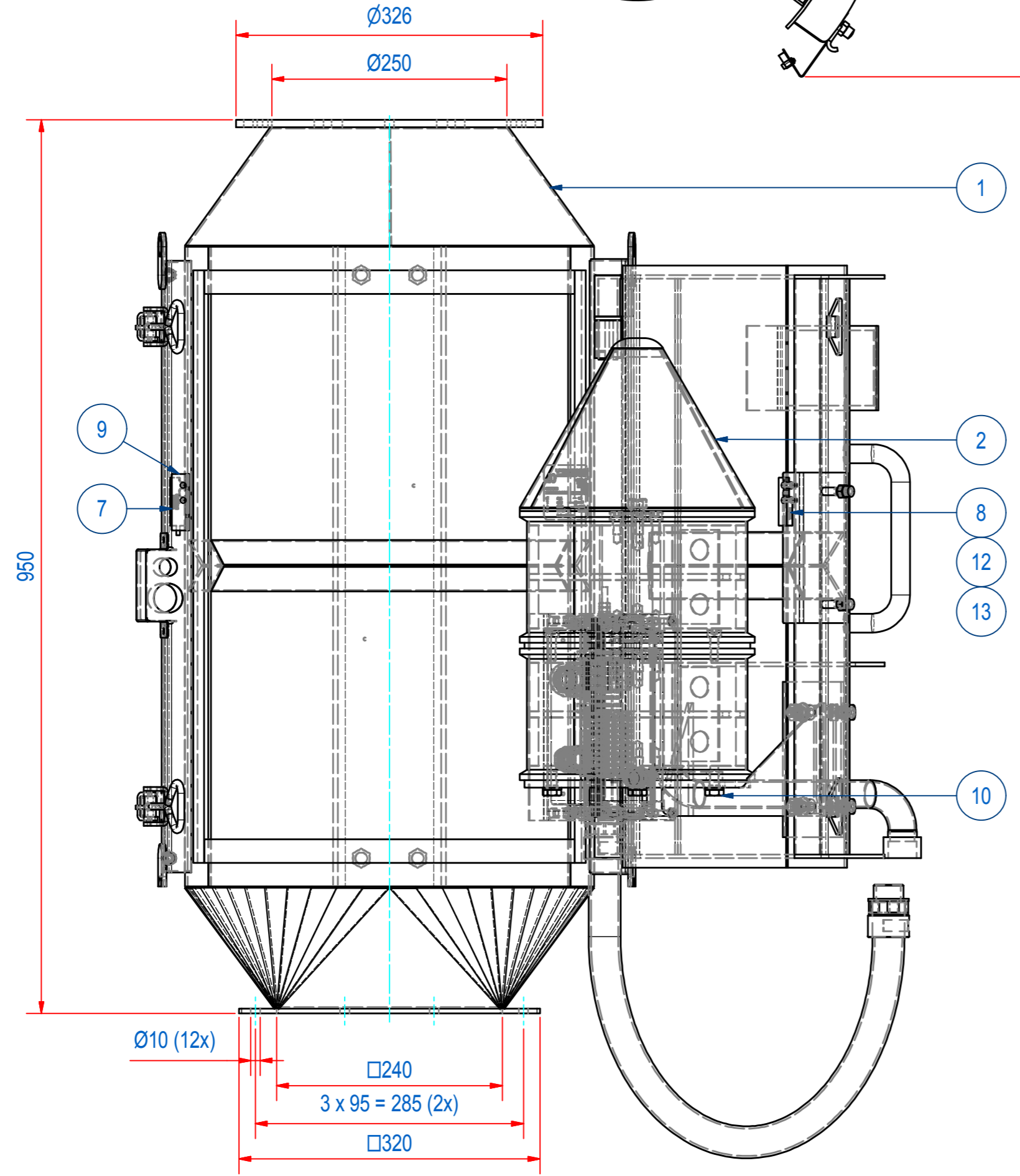
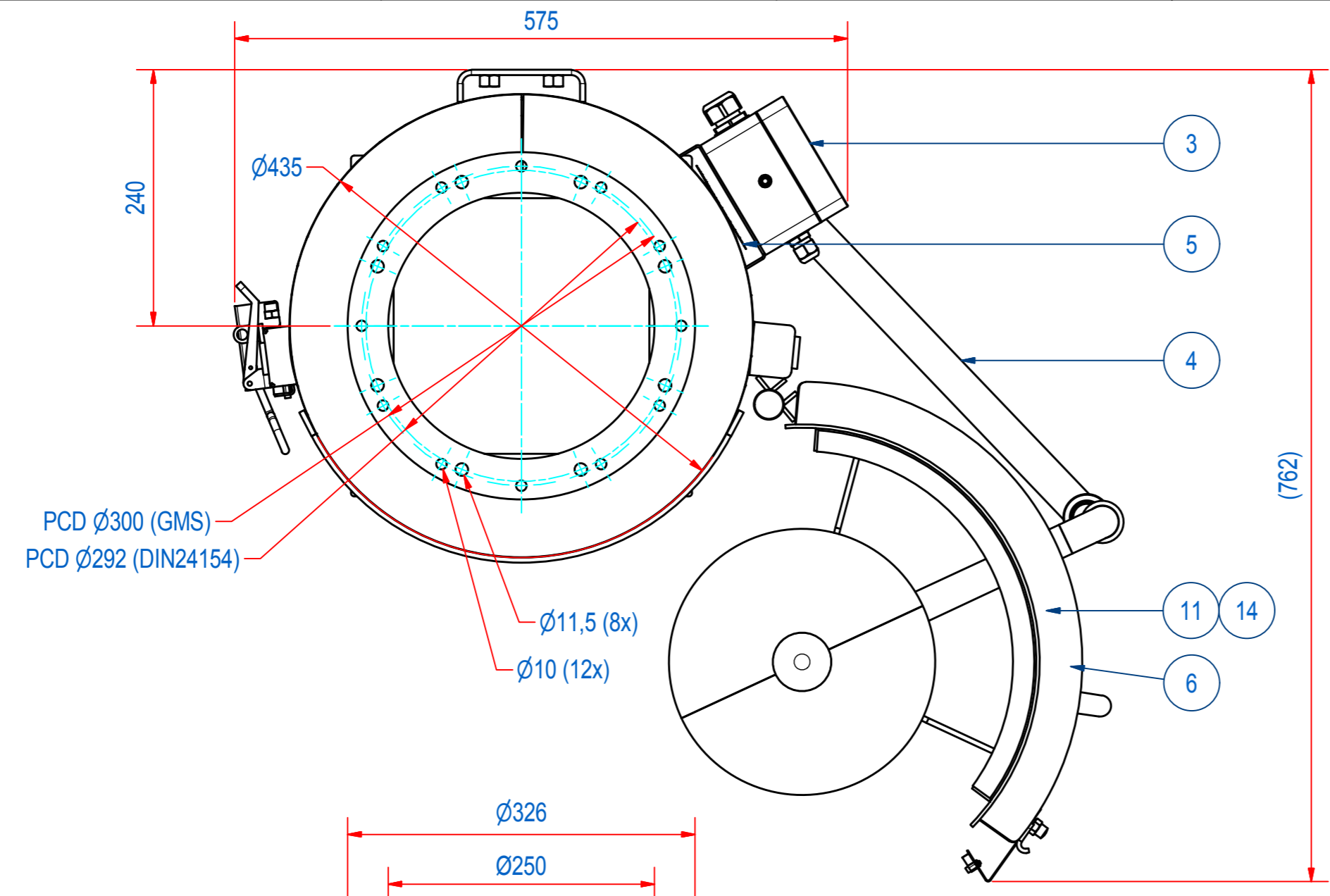

ATEX VERSION REFERS TO KEMA SCHEDULED DRAWING NR: M79009

ITEM	QTY	PART NUMBER	DESCRIPTION	Dimensions
14	8	70.0200010	WASHER M 10- A2	M 10
13	2	60.0200003	NUT, HEX M3 - A2	M3
12	4	51.0203012	SCREW, HEX SH M3 x 12 - A2	M3 x 12
11	4	51.0210020	SCREW, HEX SH M10 x 20 - A2	M10 x 20
10	4	50.1210020	BOLT, HEX M10x20 - A2	M10x20
9	1	E0011344	MAGN SWITCH COVER	
8	1	EITA542000	MAGNET for PSS P3000100	
7	1	EITA042000	CODED MAGNETIC SWITCH II2GD	
6	1	E0011316	NAME PLATE 220x80	
5	1	M60398	SPAx ATEX MARKING ExII1/2D	
4	1	A110077	CONDUIT EM3-8 Ex	
3	1	SCBTP00004	TERMINAL BOX EM3-8 EX	
2	1	SPAK005063	SPA-3-CORE-60-Ex	
1	1	SPME001063	HOUSE EM3 60° IN-OUTLET Ø250-V240	

RAW MAT.	QTY	MAT. NUMBER	MAT. DESCRIPTION	LENGTH (mm)	WIDTH (mm)
1	1				

Sheet: A2	Extra info:	General tolerance: ISO 2768 - mK
Drawn: CR	Weight (kg): 138,536	Drawn according: ISO268; ISO1101; ISO2553
Date: 24-4-2013		Status: Standard
Spare part: False		Customer reference number:
Quick search: EM3 EX	GOUDSMIT MAGNETIC SYSTEMS	File number: SPAE000063 Rev: A
Description: SPA-3-B-TC-OS-ST-Ex-D-B	© All rights reserved. Reproduction is not permitted without written permission of GOUDSMIT Magnetic Systems BV	Part number: SPAE000063 Rev: A