

REV	DATE	BY	DESCRIPTION
-	22-3-2013	CR	ORIGINAL INVENTOR DRAWING
A	7-1-2014	AvD	NAME PLATE AND PLATE FOR SENSOR ADDED
B	3-6-2014	CR	HEIGHT CHANGED: 1300MM WAS 1370MM

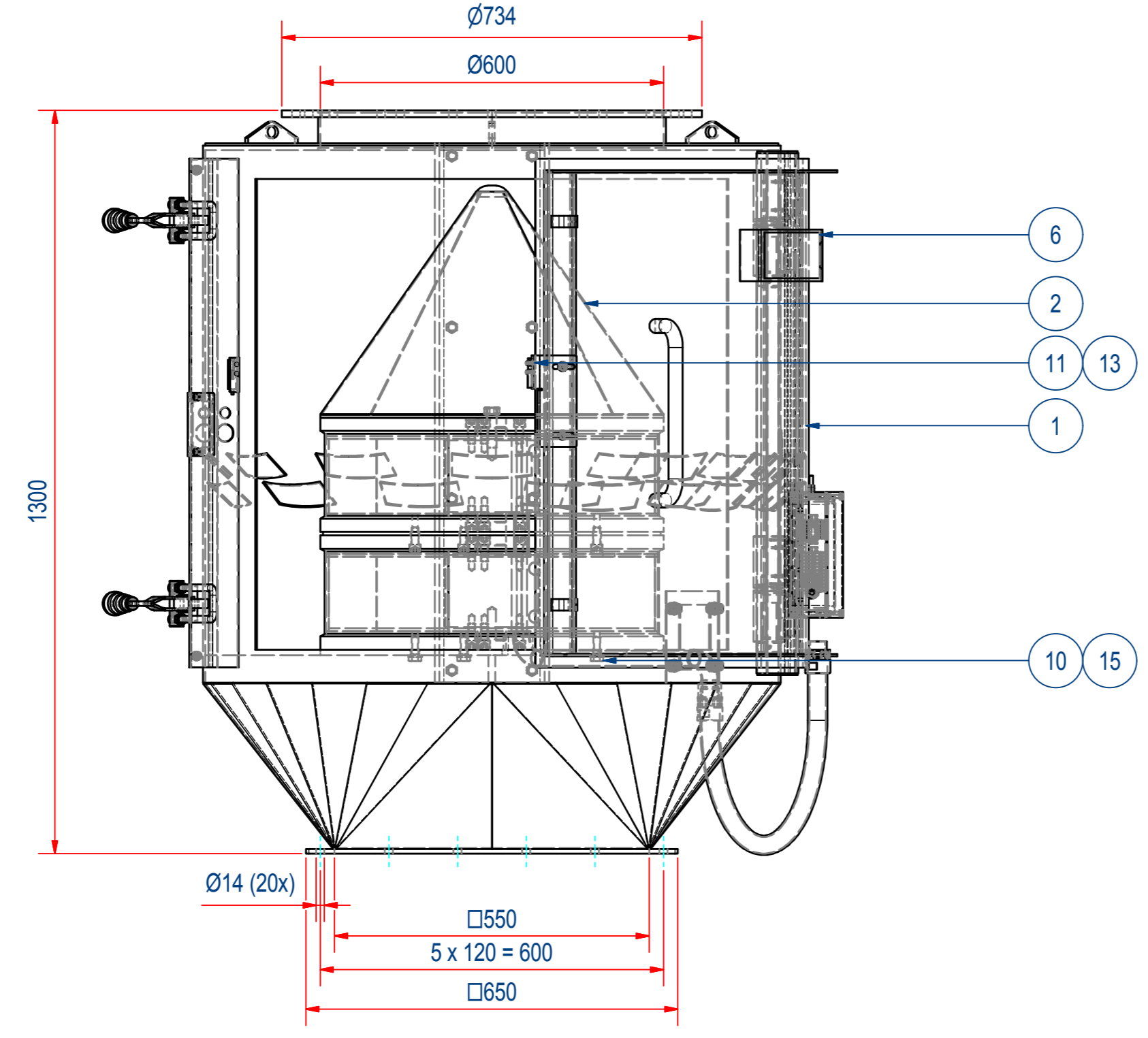
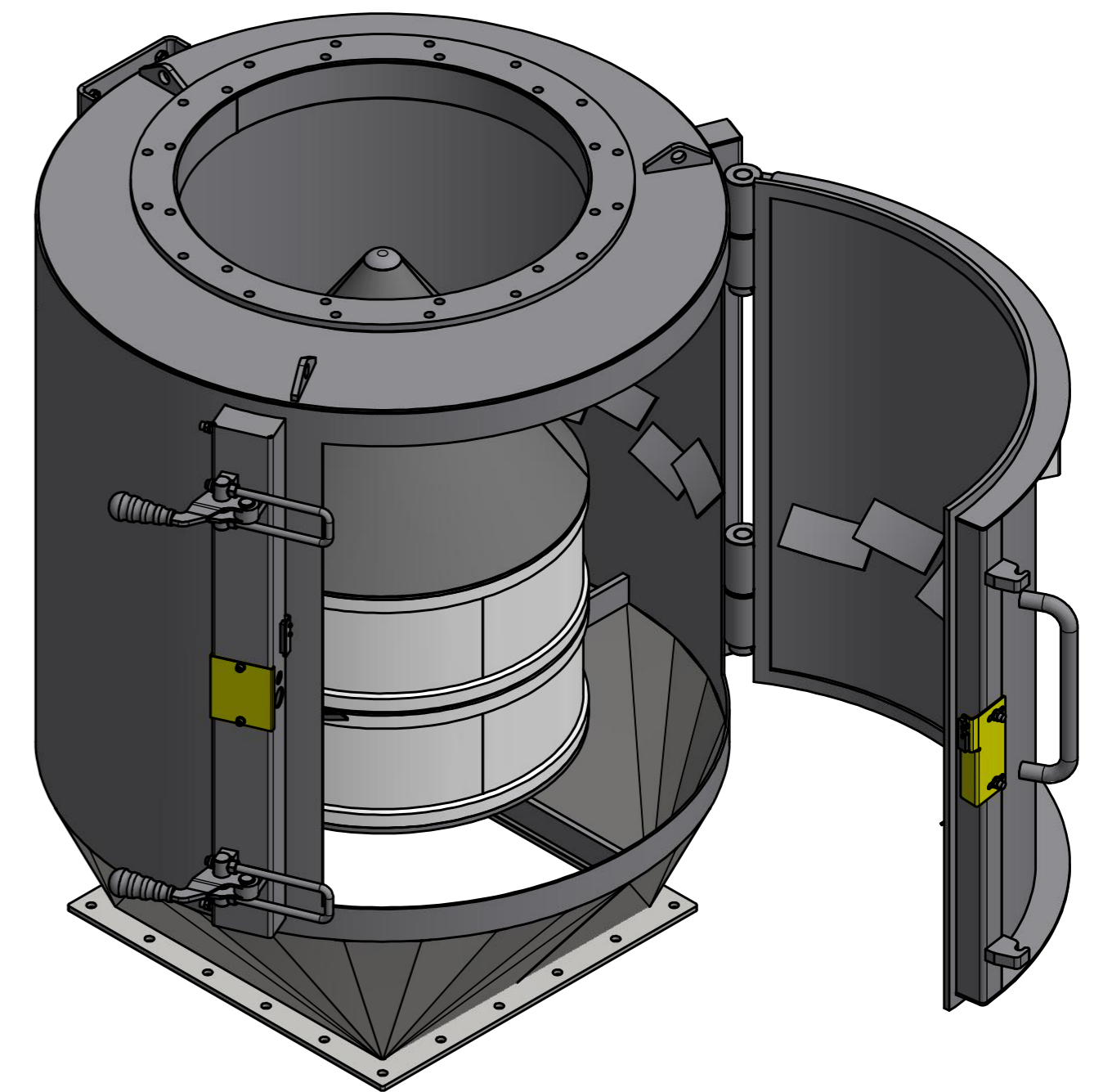
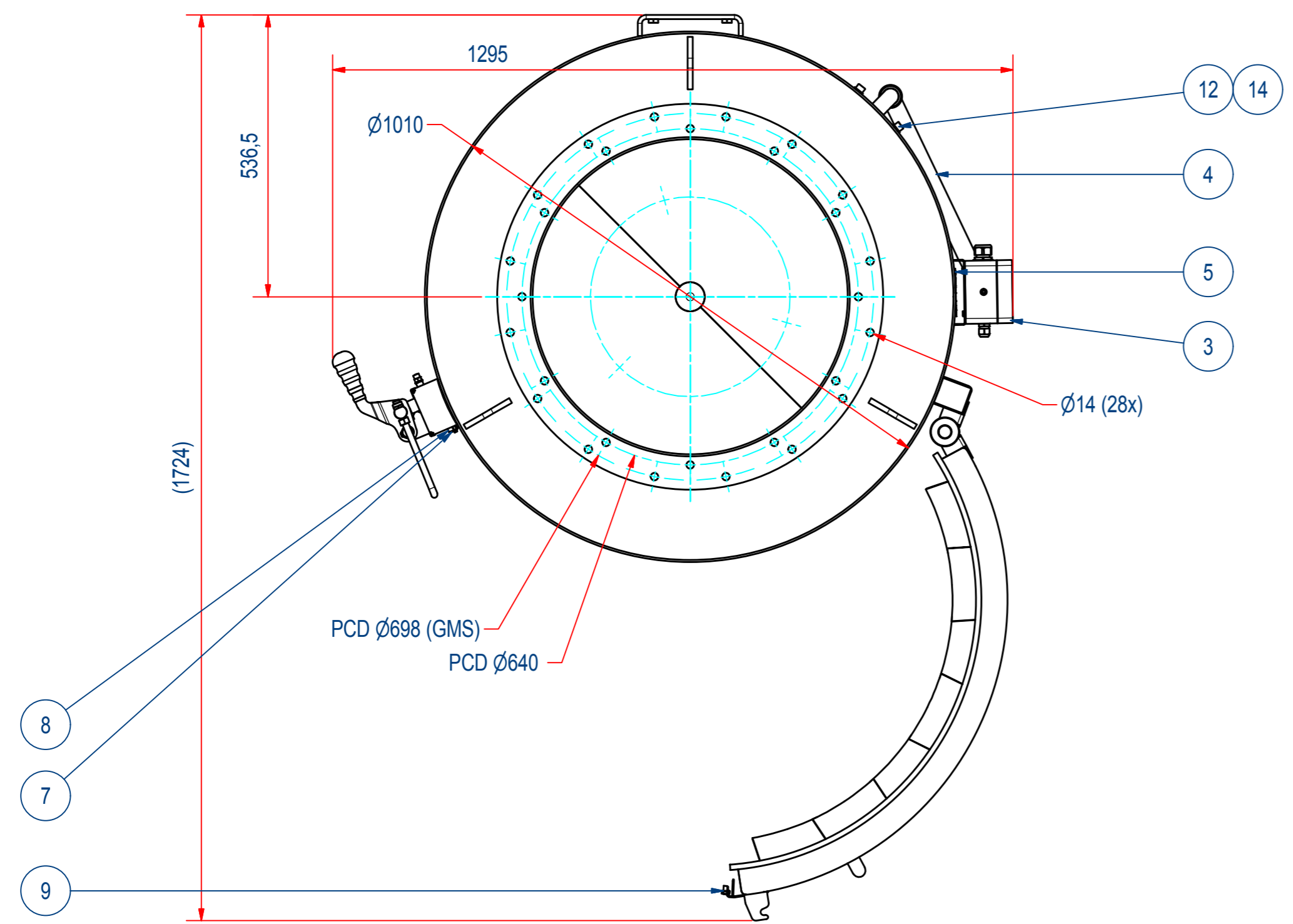

ATEX VERSION REFERS TO KEMA SCHEDULED DRAWING NR: M79009

ITEM	QTY	PART NUMBER	DESCRIPTION	Dimensions
15	3	70.0200012	WASHER M 12- A2	M 12
14	4	70.0200010	WASHER M 10- A2	M 10
13	2	60.0200003	NUT, HEX M3 - A2	M3
12	4	51.0210020	SCREW, HEX SH M10 x 20 - A2	M10 x 20
11	4	51.0203012	SCREW, HEX SH M3 x 12 - A2	M3 x 12
10	3	50.1212035	BOLT, HEX M12x35 - A2	M12x35
9	1	EITA542000	MAGNET for PSS P3000100	
8	1	EITA042000	CODED MAGNETIC SWITCH II2GD	
7	1	E0011344	MAGN SWITCH COVER	
6	1	E0011316	NAME PLATE 220x80	
5	1	M60398	SPAx ATEX MARKING ExII1/2D	
4	1	A110077	CONDUIT EM3-8 Ex	
3	1	SCBTP00004	TERMINAL BOX EM3-8 EX	
2	1	SPAK005067	SPA-7-CORE-60-Ex	
1	1	SPME001067	HOUSE EM7 70° IN-OUTLET Ø550-V550	

RAW MAT.	QTY	MAT. NUMBER	MAT. DESCRIPTION	LENGTH (mm)	WIDTH (mm)
1	1				

Sheet: A2	Extra info:	General tolerance: ISO 2768 - mK
Drawn: CR	Weight (kg): 963,076	Drawn according: ISO268; ISO1101; ISO2553
Date: 22-3-2013		Status: Standard
Spare part: False		Customer reference number:
Quick search: EM7 EX	GOUDSMIT MAGNETIC SYSTEMS	File number: SPAE000067
Description: SPA-7-B-FI-OS-ST-Ex-D-B	© All rights reserved. Reproduction is not permitted without written permission of GOUDSMIT Magnetic Systems BV	Rev: B
		Part number: SPAE000067
		Rev: B