

REV	BY	DATE	DESCRIPTION
-	PW	27.07.2018	New Vault, nothing changed, old rev.F

HOISTING LUG  
B (1:5)

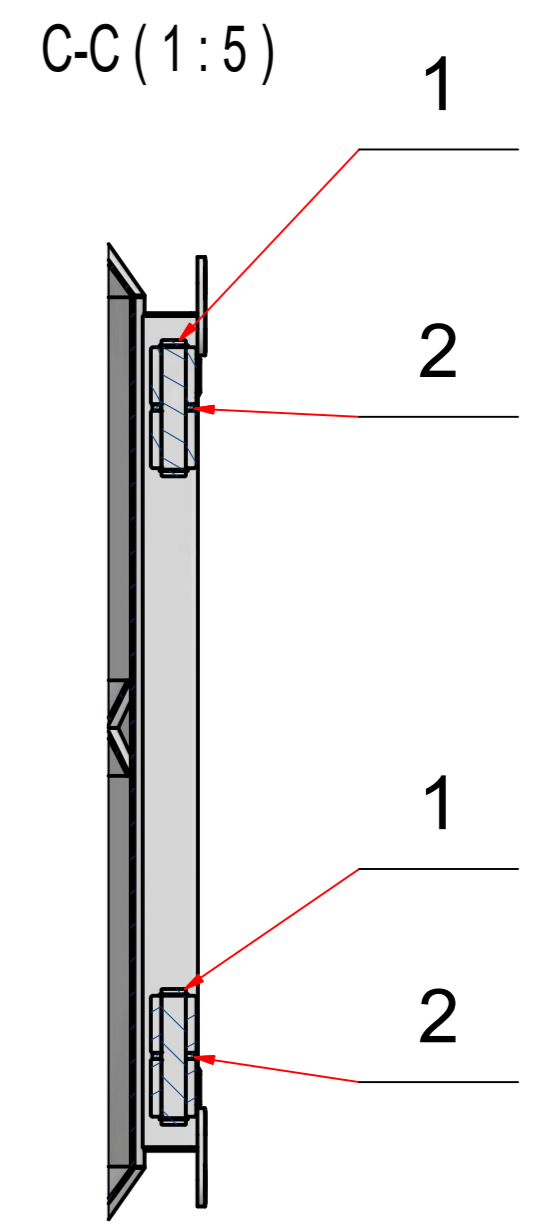

HOLE D19 FOR M18 DOORSENSOR  
HOLE D31 FOR M30 DOORSENSOR

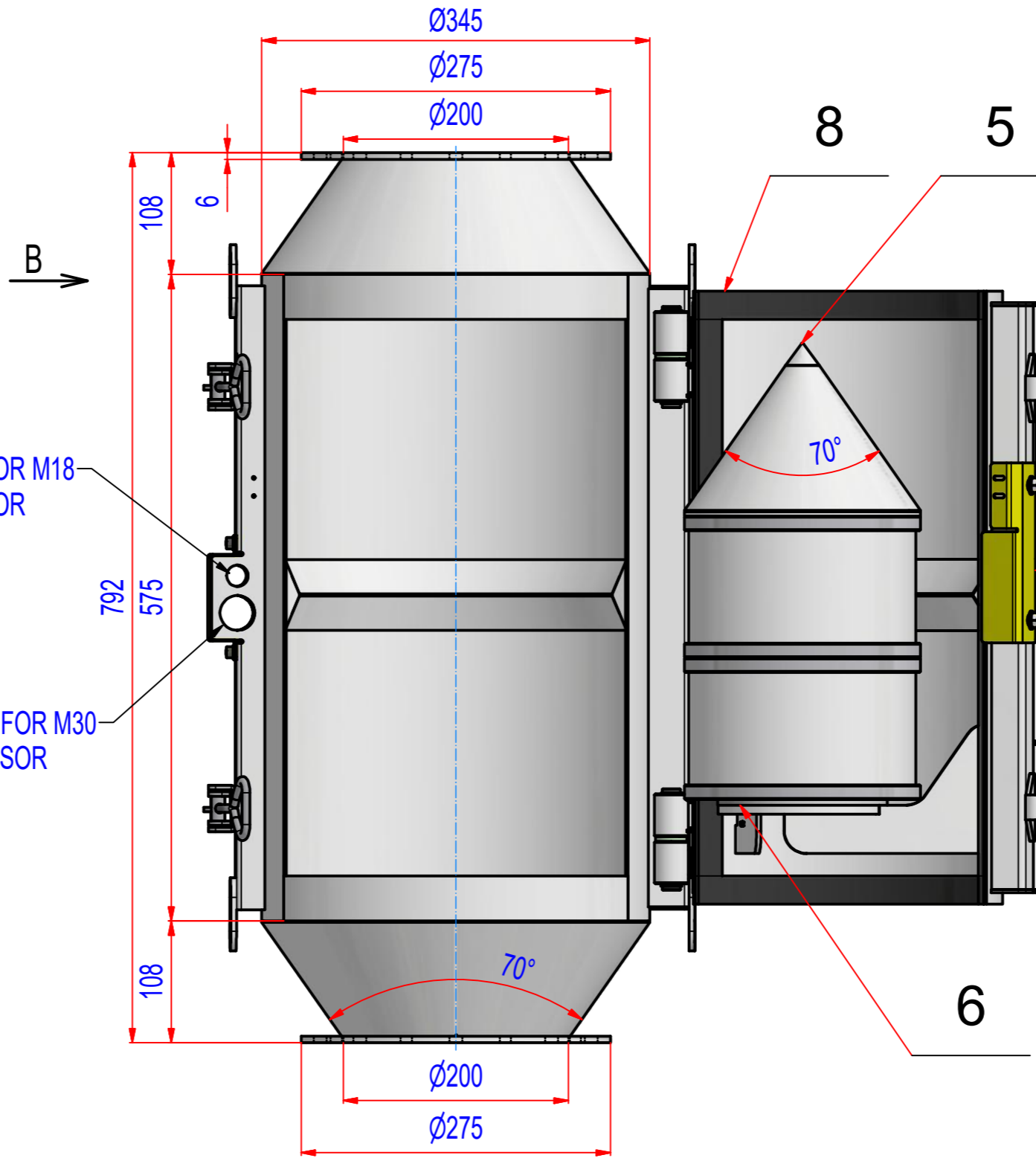
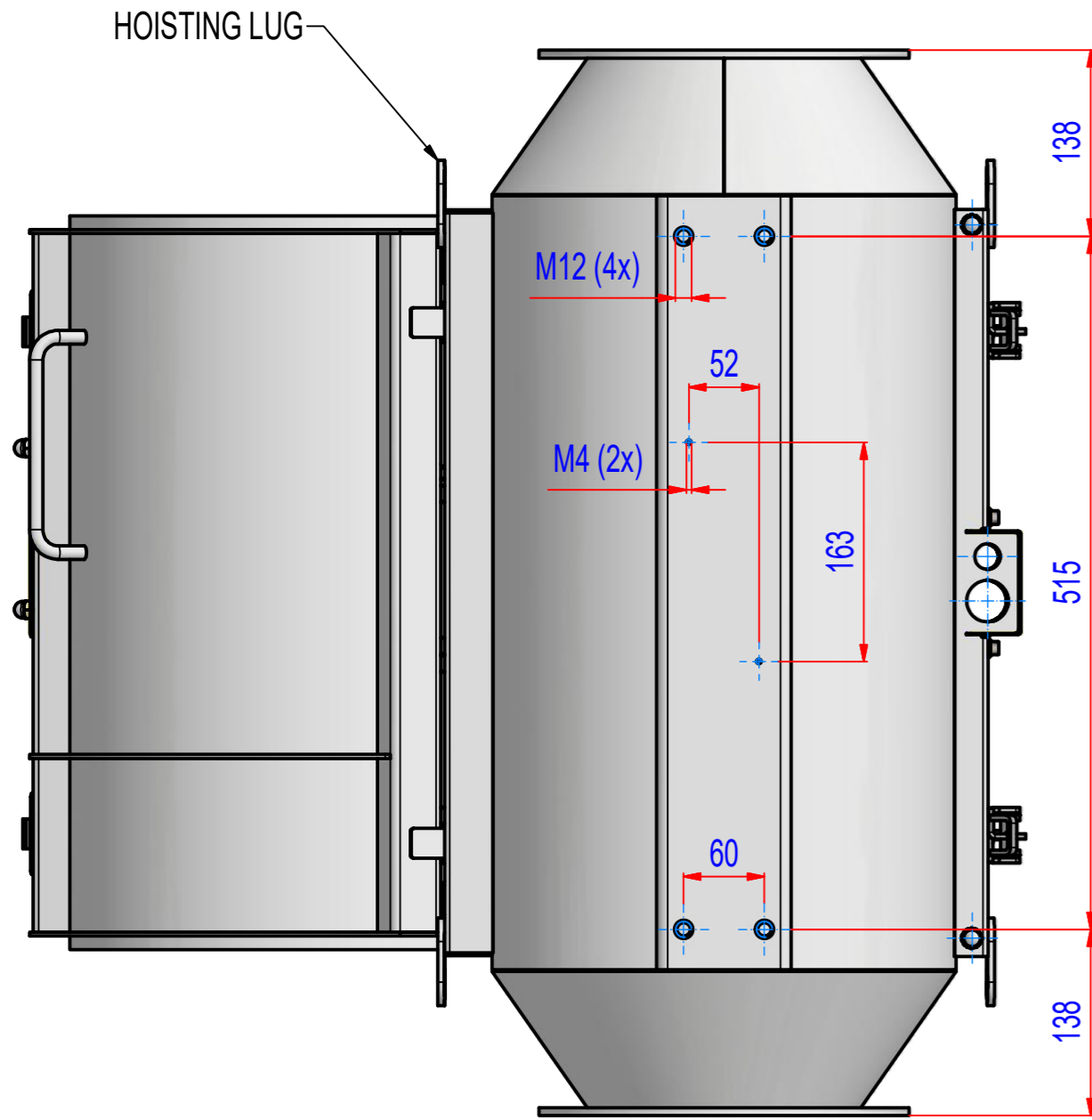
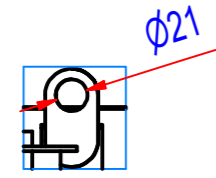
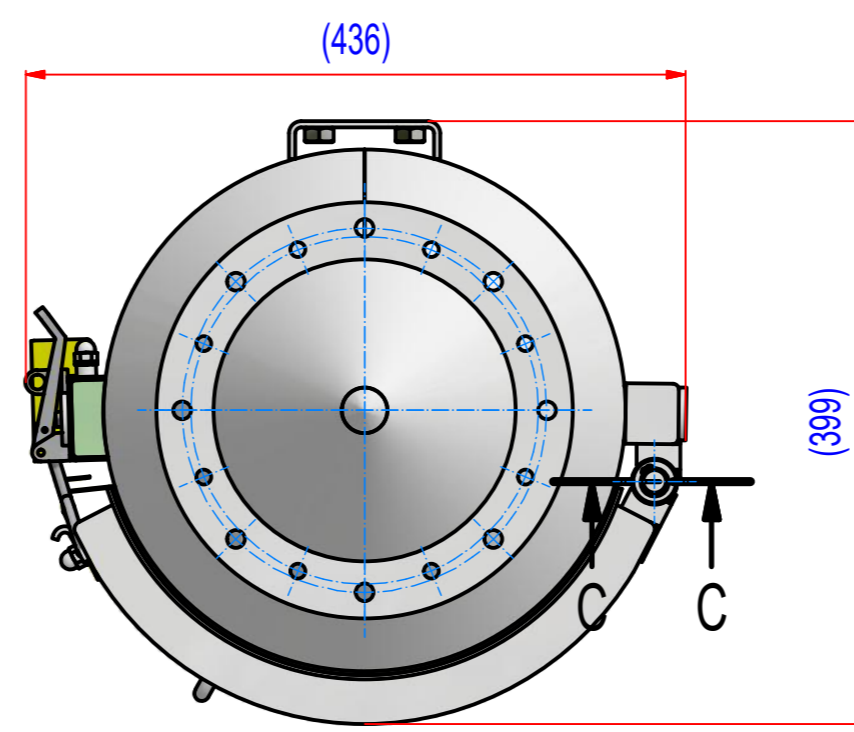
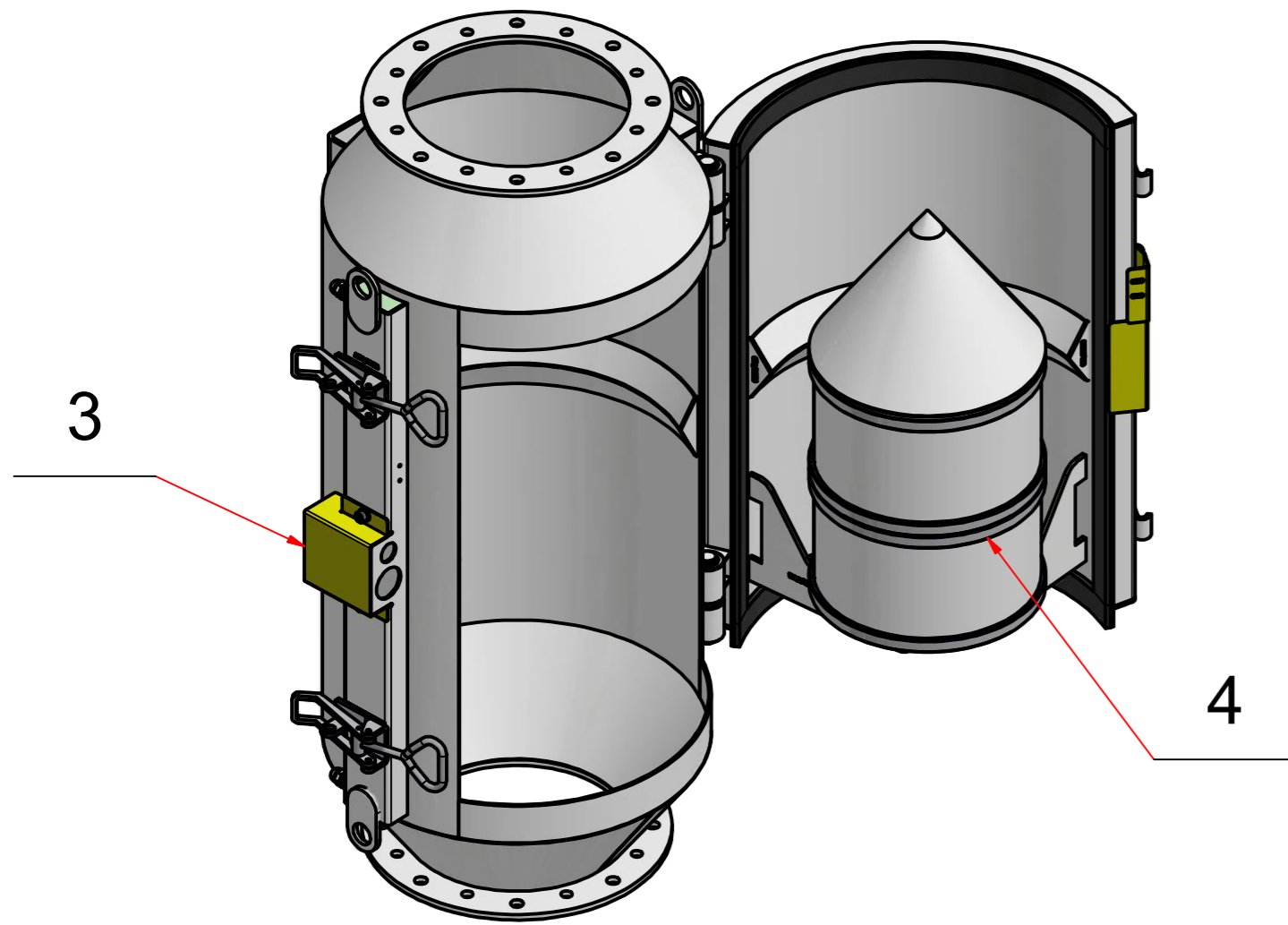

POZ.	Č. SOUČÁSTI	POPIS	MATERIÁL	HMOT.	MN.
8	A004_000001	Gasket PM2; 25x5, L=1870mm	Silikon	0,3	1
7	G37_000003_B	Sensor plate	AISI304	0,1	1
6	G37_020003	Slide pad magnet PM2		0,1	1
5	G37_030300	Cone for PM2 70 st	AISI304	2,2	1
4	H54_030000	Magnet core for PM2 - 60°		42	1
3	G32_010302	Cover for sensor	AISI304	0,1	1
2	G80_010007	Washer wear PM1	POLYAMID	0	2
1	G80_010006	Hinge pin for PM1	AISI304	0,1	2

Sheet: A2 Drawn: PW Date: 27.07.2018 Predecessor:	Extra info:  © All rights reserved. Reproduction is not permitted without written permission of GOUDSMIT Magnetic Systems BV.	General tolerance: ISO 2768 - cL Drawn according: ISO268; ISO1101; ISO2553 Status: Customer reference number: Product key: SPP-2-TC-FO-S4-B-BB Part number: SPPE000162_SP Rev: -
Quick search: XSPP 2 Description: Spare parts for SPPE000162		