

REV	BY	DATE	DESCRIPTION
-	PW	11.05.2017	New Vault, nothing changed, old rev.C

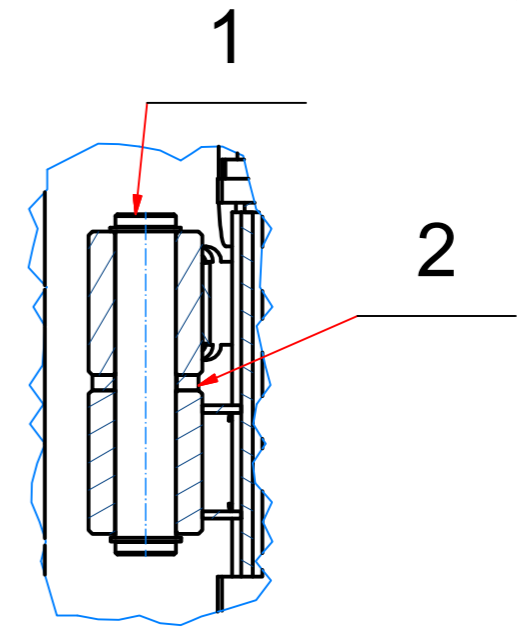
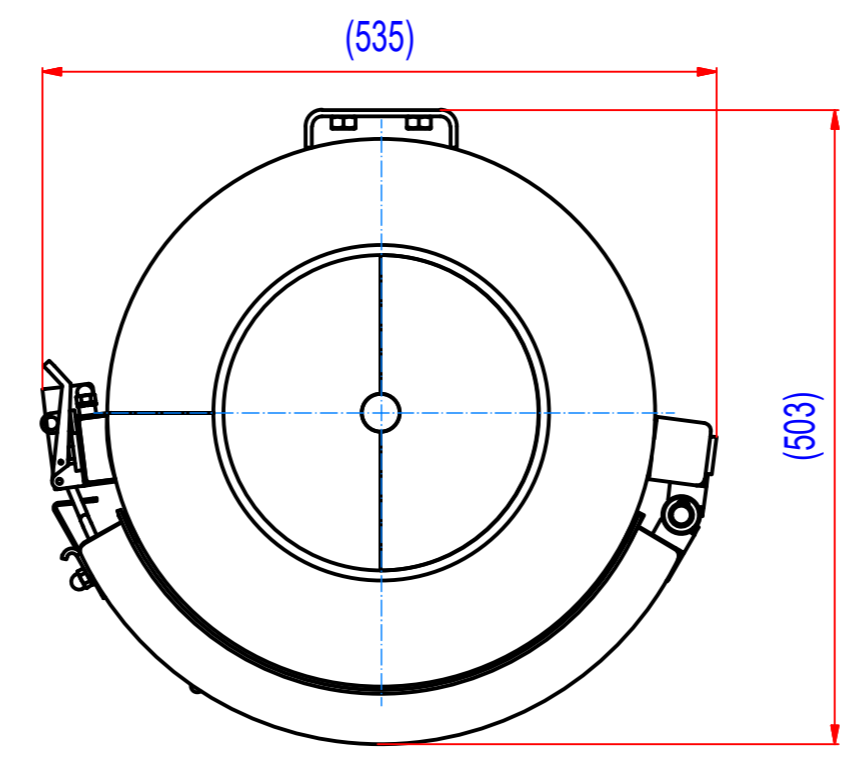
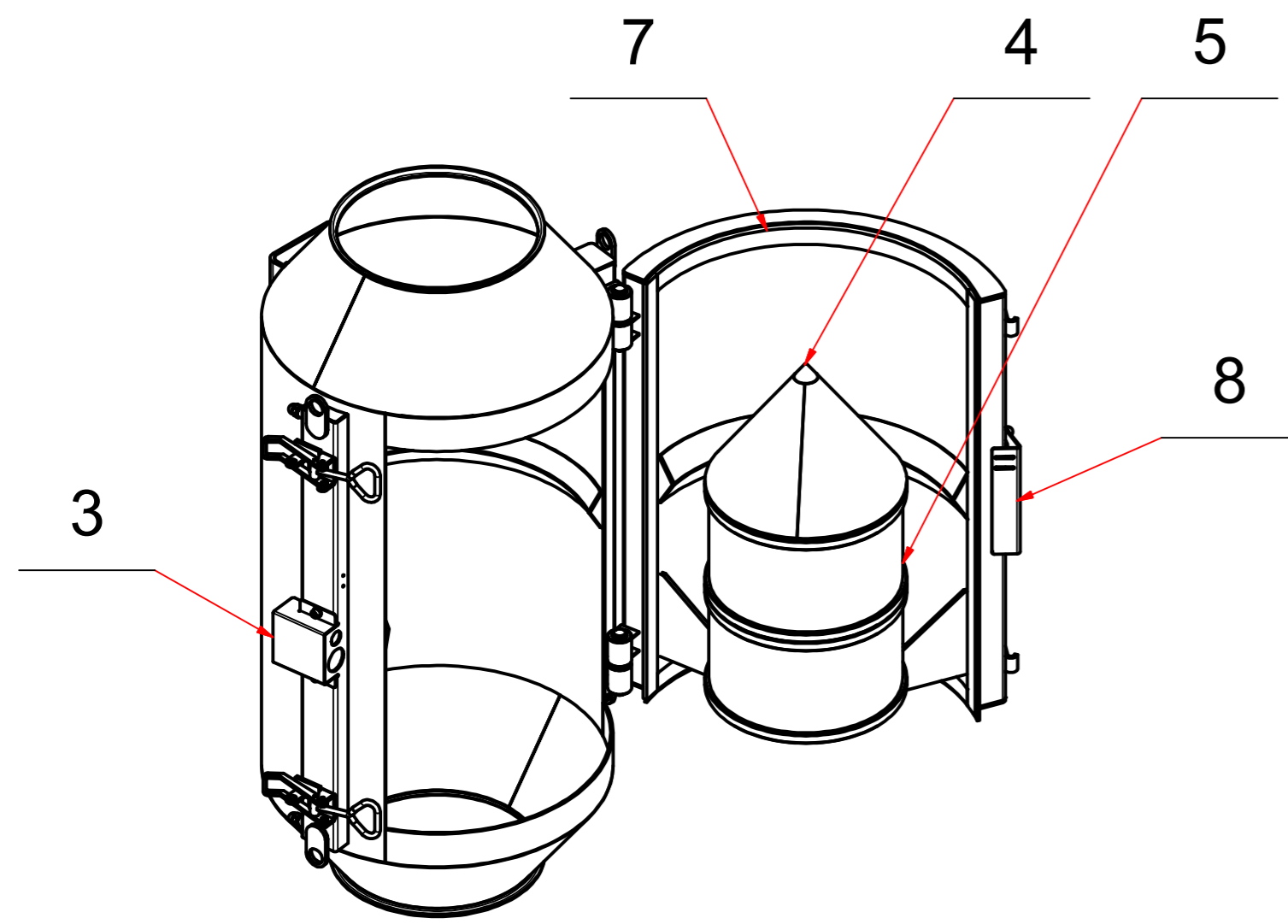
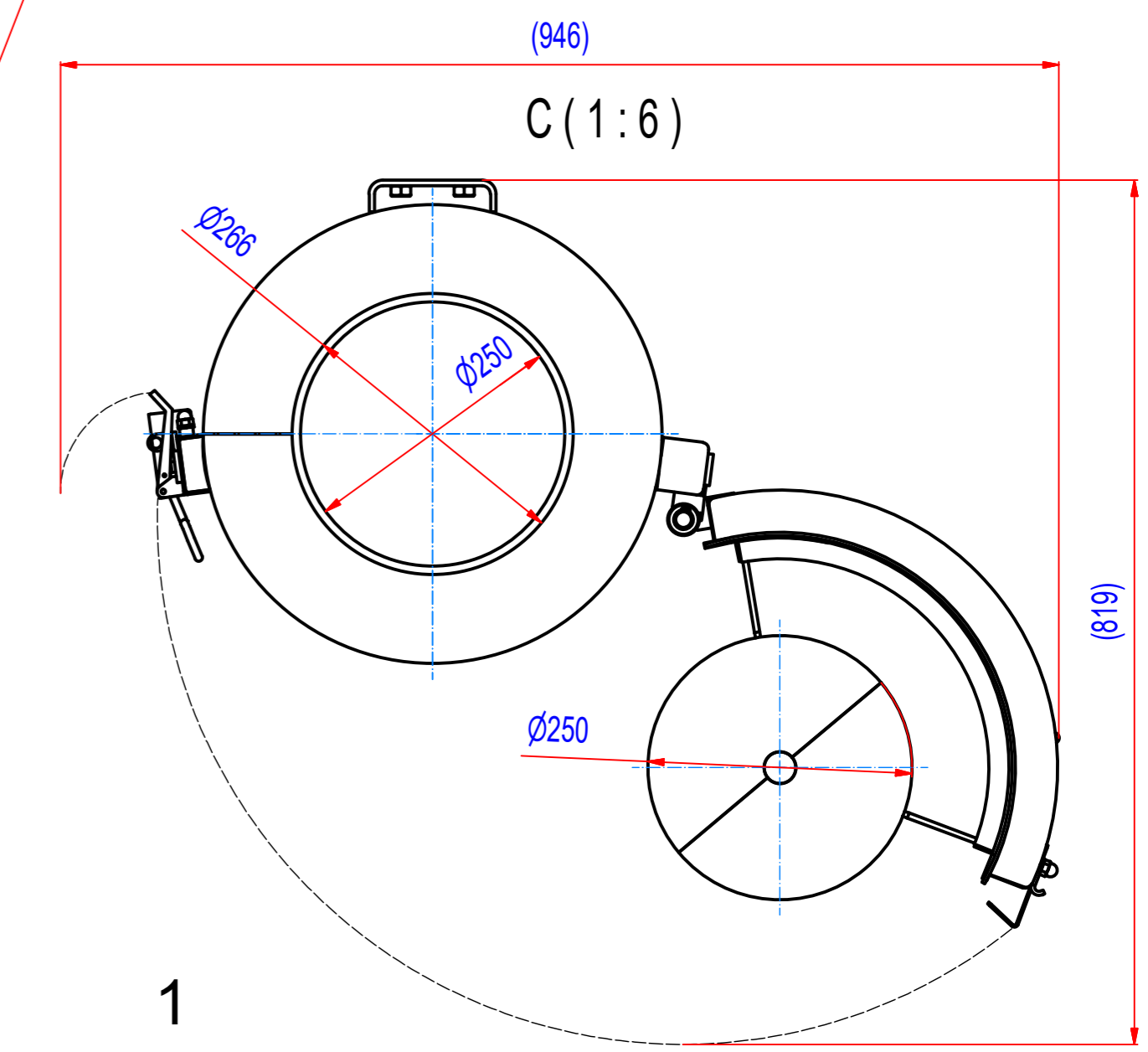
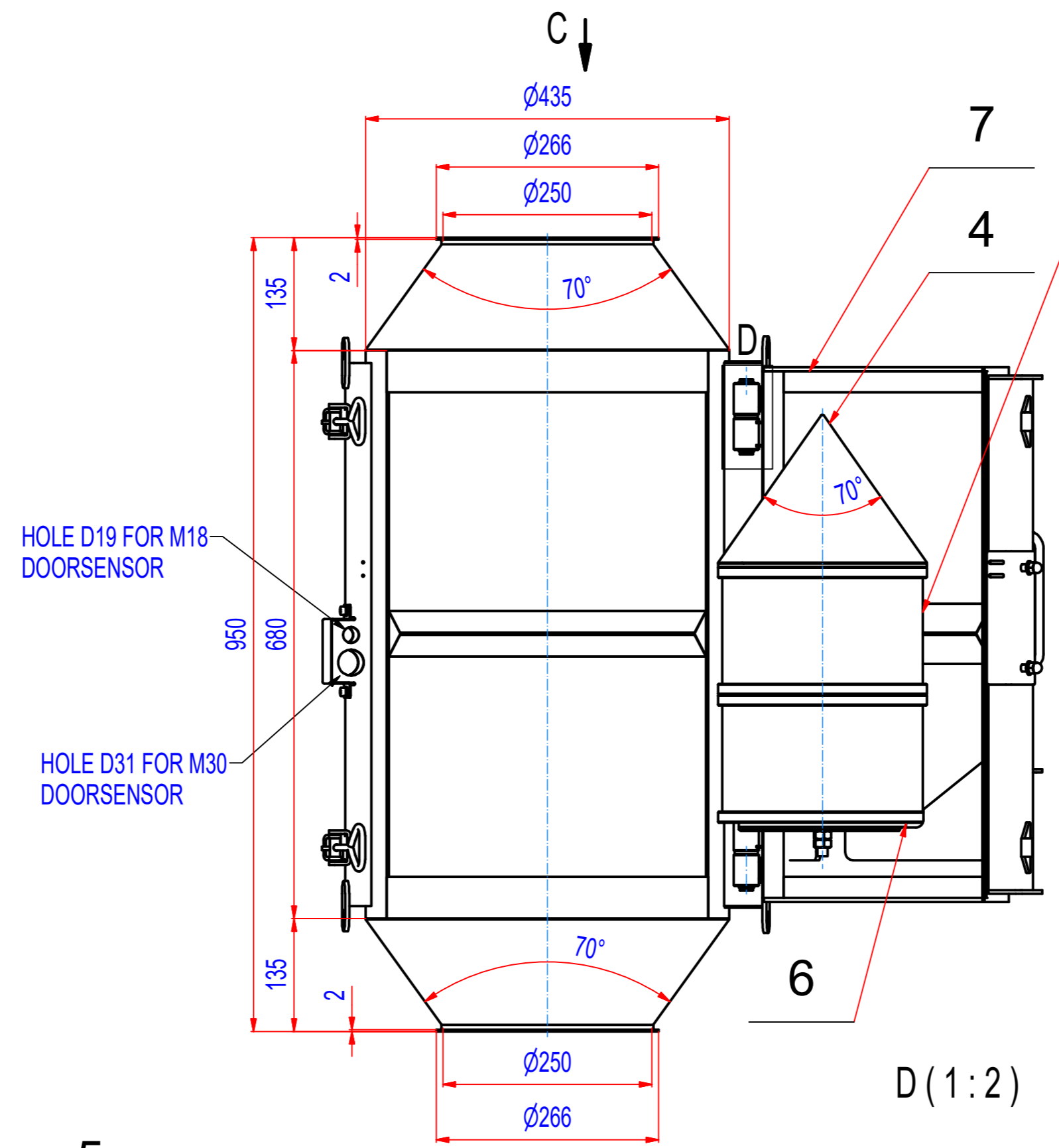
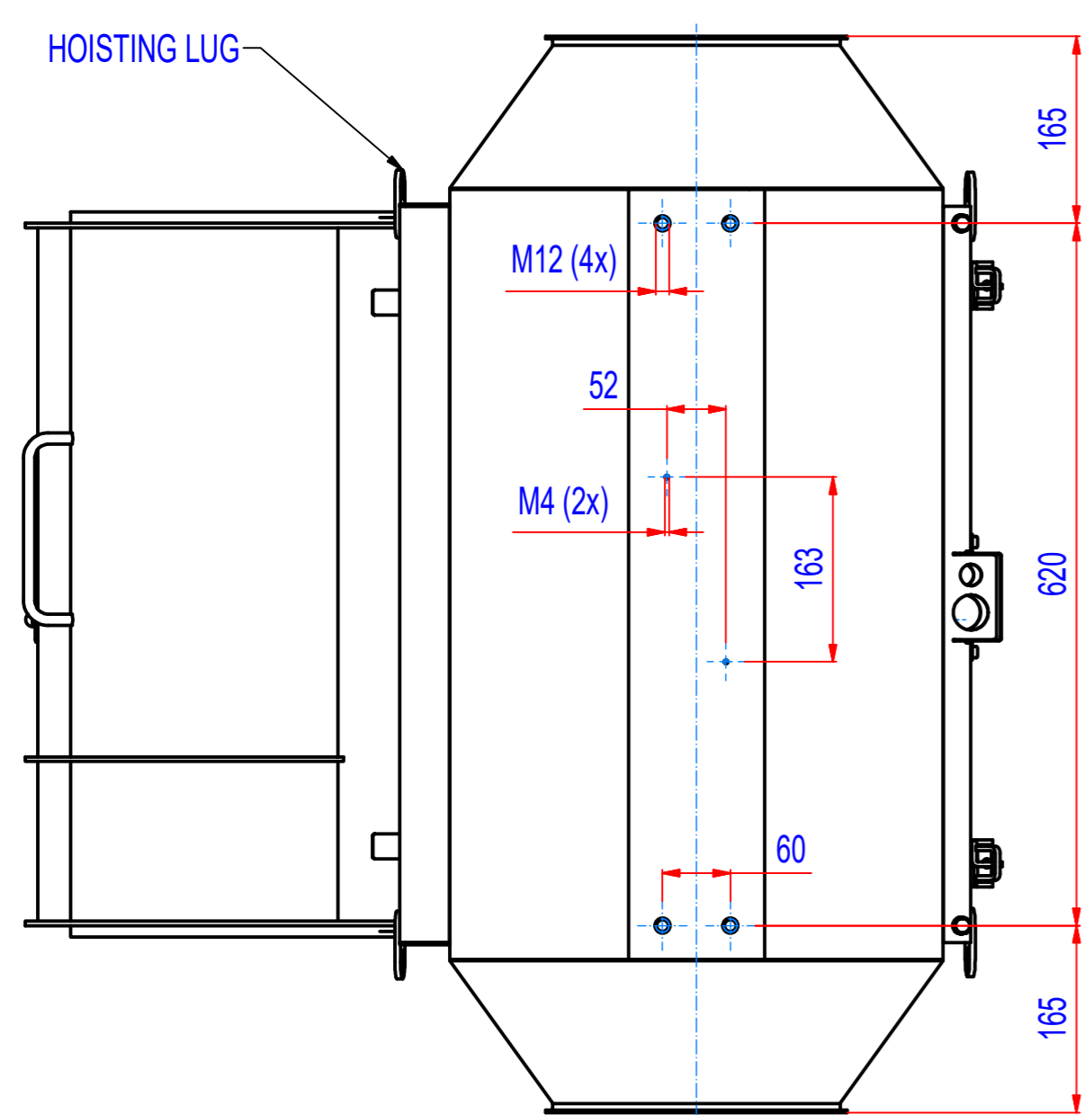

POZ.	Č. SOUČÁSTI	POPIS	MATERIÁL	HMOT.	MN.
8	G32_000004	Sensor plate	S235JR (11373)	0,3	1
7	A031_000001	Band PM3 25x5, L=2230mm	Silikon	0,3	1
6	G32_020001	Slide pad for PM3		0	1
5	389_030004	Magnet core PM3		64	1
4	G32_030102	Cone for PM3, 70dgr	AISI304	0,1	1
3	G32_010302	Cover for sensor	AISI304	0,1	1
2	G80_010007	Washer wear PM1	POLYAMID PA6	0	2
1	G80_010006	Hinge pin PM1	AISI304	0,1	2

Sheet: A2	Extra info:	General tolerance: ISO 2768 - cL
Drawn: PW	Weight (kg): 113,8	Drawn according: ISO268; ISO1101; ISO2553
Date: 11.05.2017		Status:
Predecessor:		Customer reference number:
Quick search: XSP3	<p>© All rights reserved. Reproduction is not permitted without written permission of GOUDSMIT Magnetic Systems BV</p>	Product key: SPP-3-TC-FJ-ST-B-BB
Description: Spare parts for SPPE010063		Part number: SPPE010063_SP