

REV	DATE	BY	DESCRIPTION
A	8.2.2011	JKA	REF: SPPE010064w

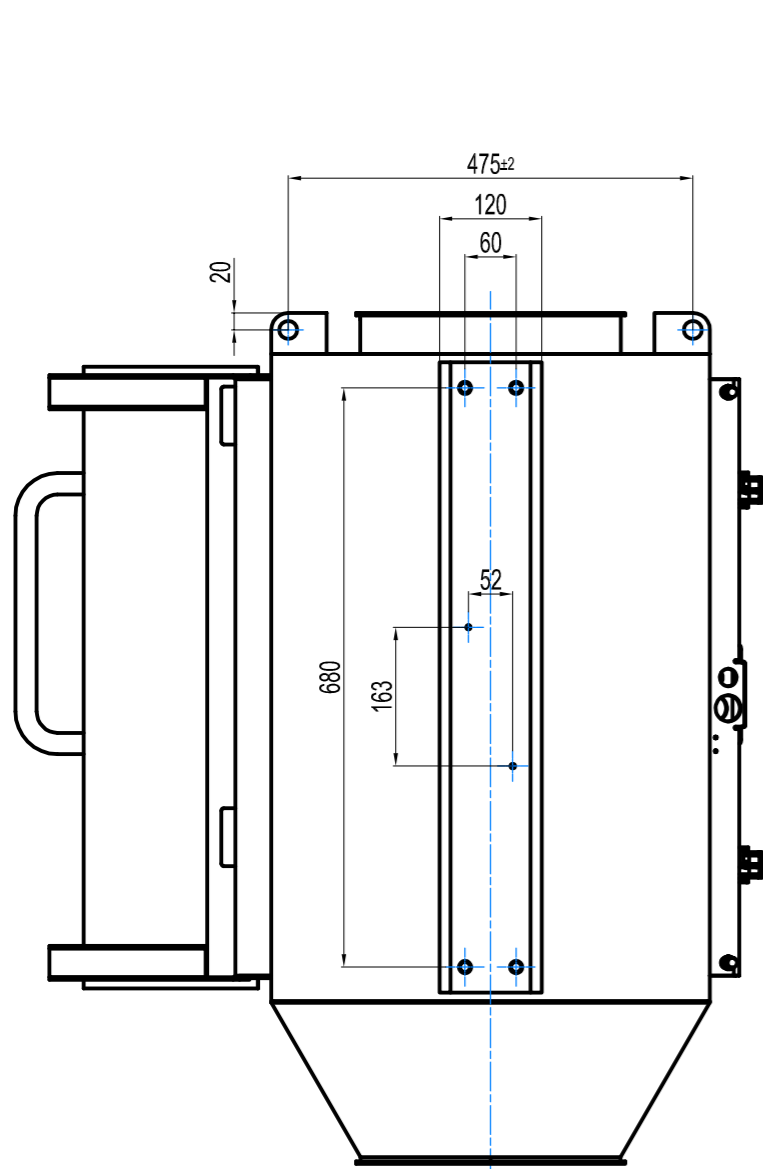

HOLE D19 FOR M18 DOORSENSOR  
HOLE D31 FOR M30 DOORSENSOR

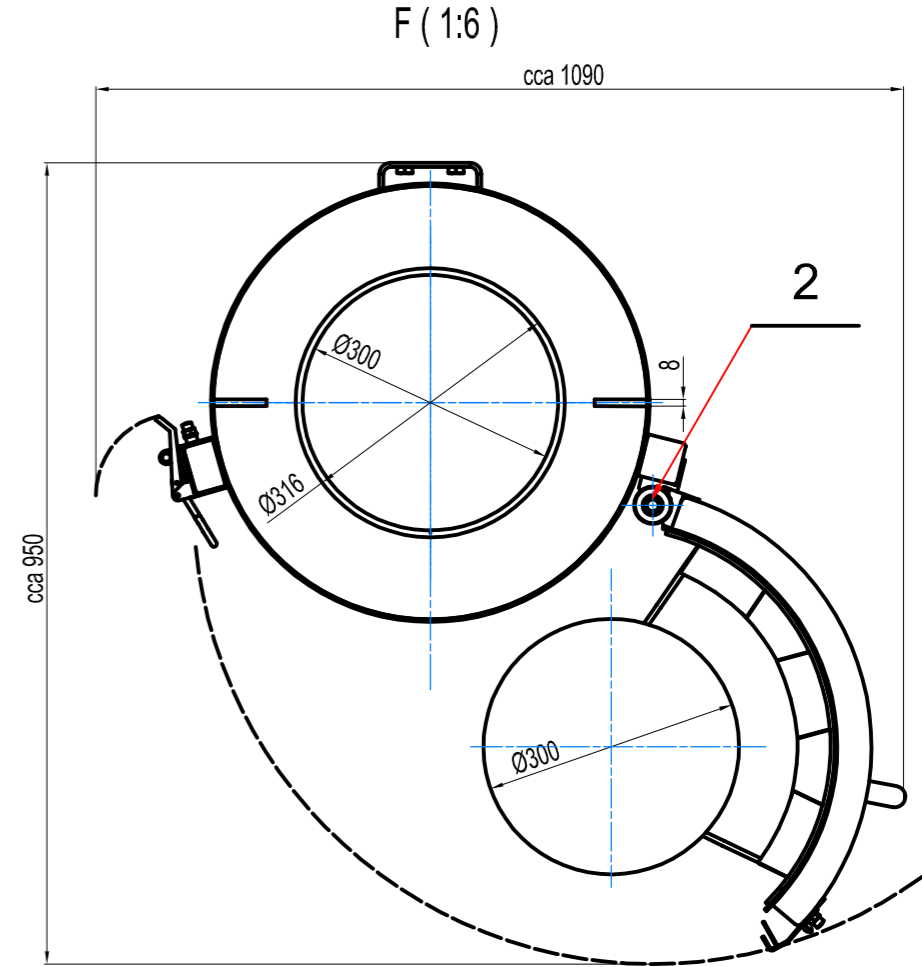
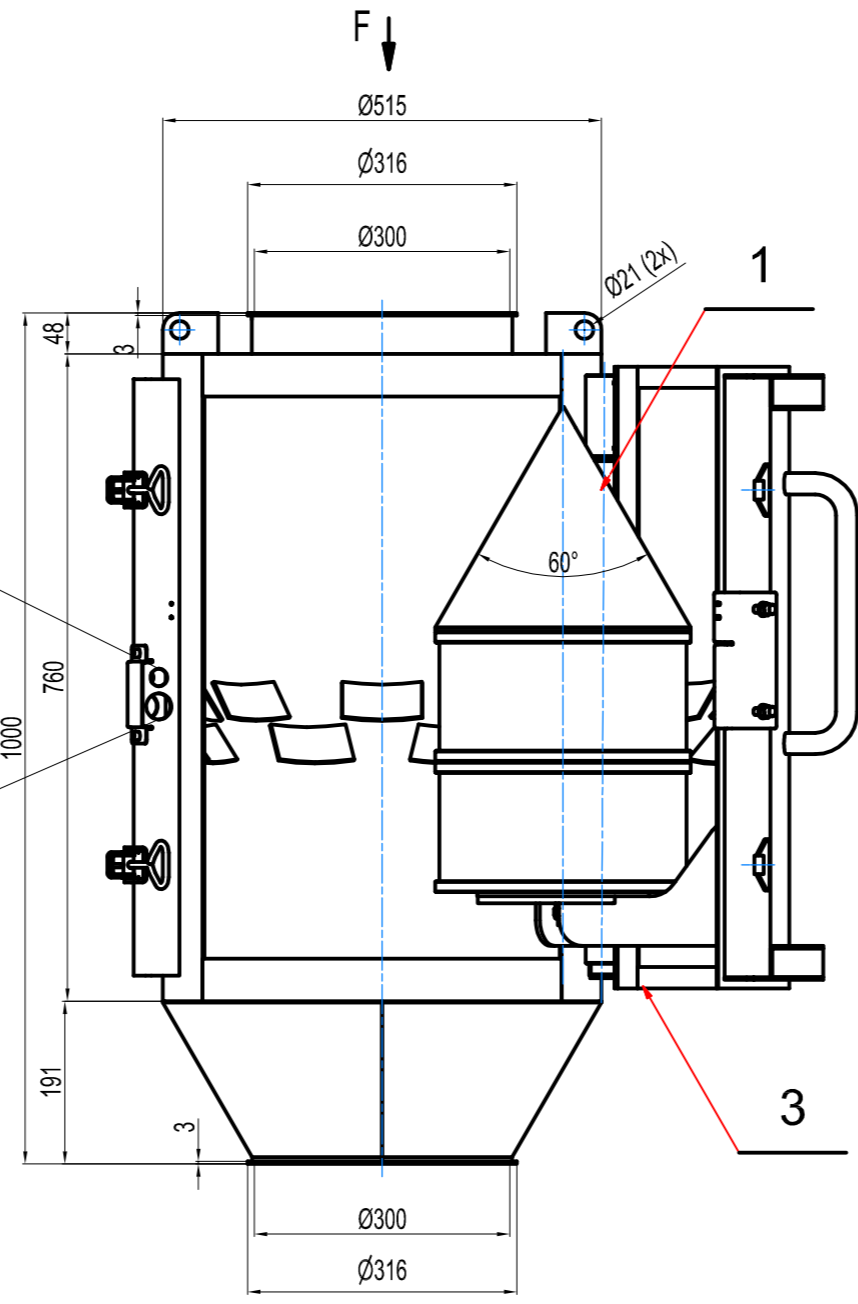

POZ.	MN.	Č. SOUČÁSTI	POPIS	MATERIAL	HMOT.
3	2	G35 000001 BV	Band 25x5, L=2,5 m		0,1
2	2	15 1151204	BEARING 51204		0,1
1	1	G35 030000 B	CONE PM4 60DGR		96,9

General Tolerances (not tol. measures) ISO 2768 - cL	General Tolerances on weld length	Drawing rules acc.	
Drawn: JKA	Scale: 1:6	Order:	Quant:
Date: 8.2.2011	Status:	Partorder:	

Title: SPARE PARTS FOR SPPE010064w STANDARD ST/AISI304, TOTAL WEIGHT 180 KG, JACOB QUICK CONNECT	
<b>GOUDSMIT</b> Magnetic systems	Number: SPPE010064w_SP Rev: A