

REV	BY	DATE	DESCRIPTION
-	PW	08.02.2017	New Vault, nothing changed, old rev.B

HOISTING LUG
B (1:5)

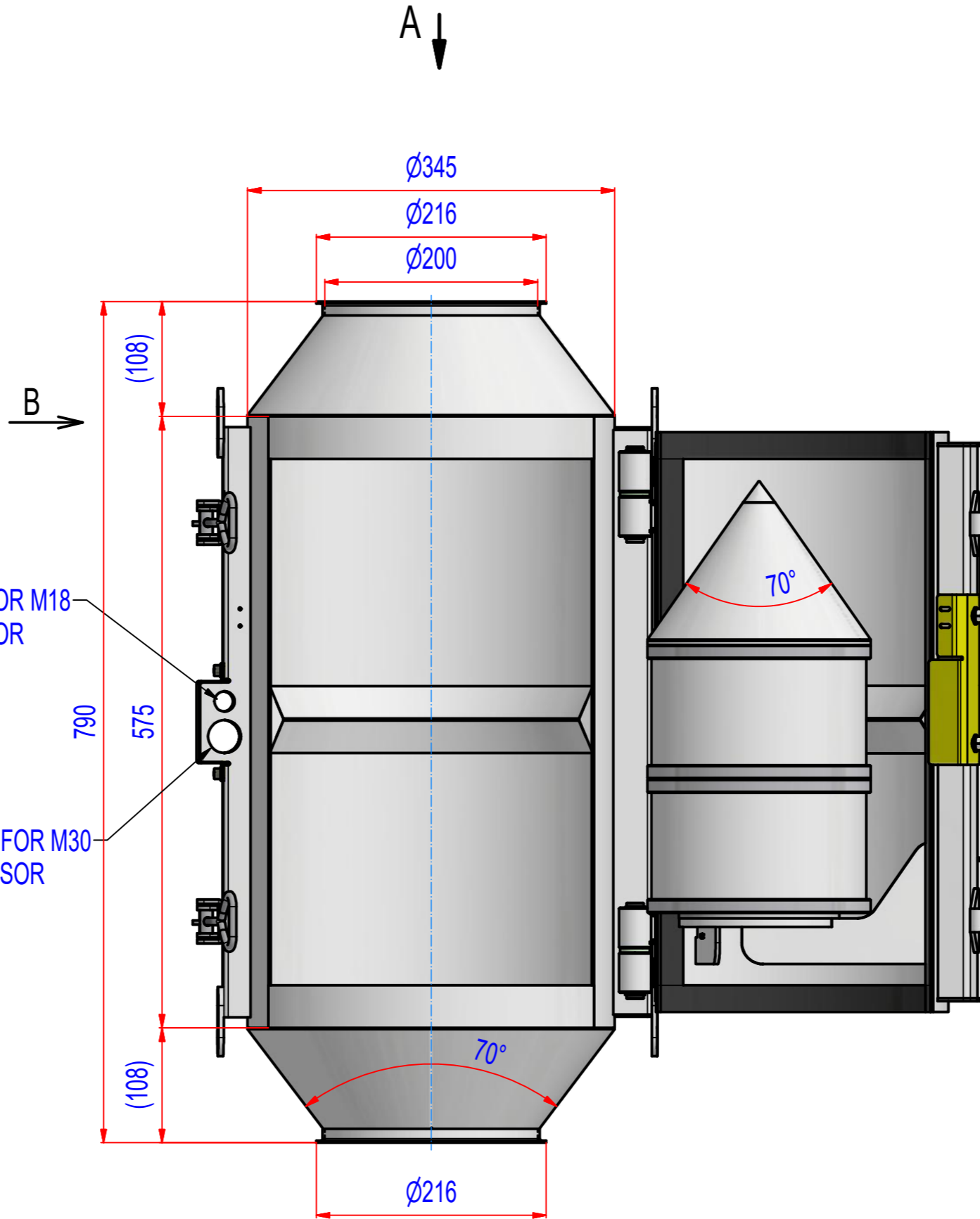

A (1:5)
(751)

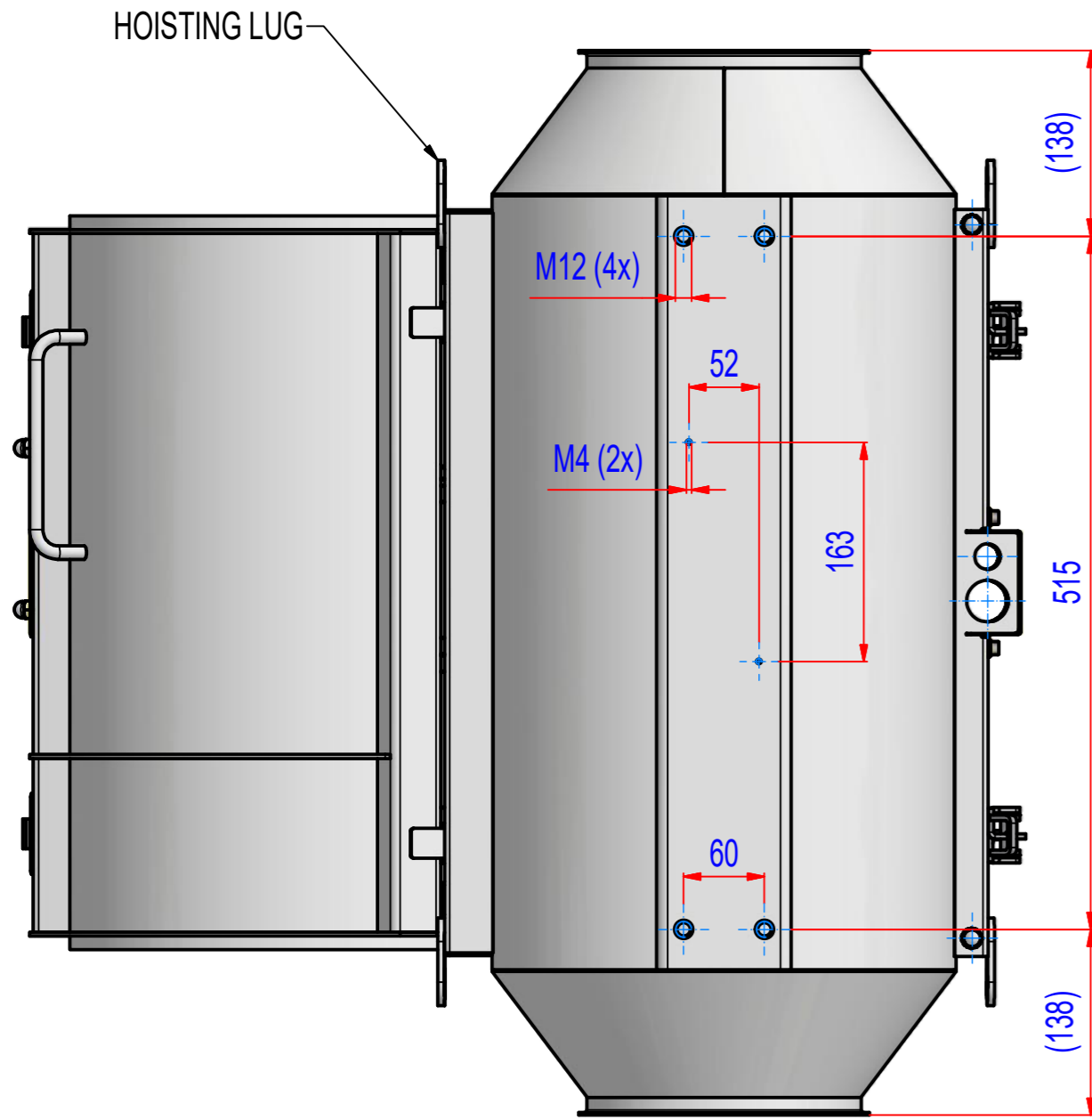
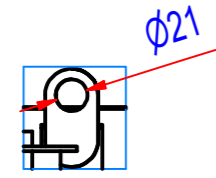
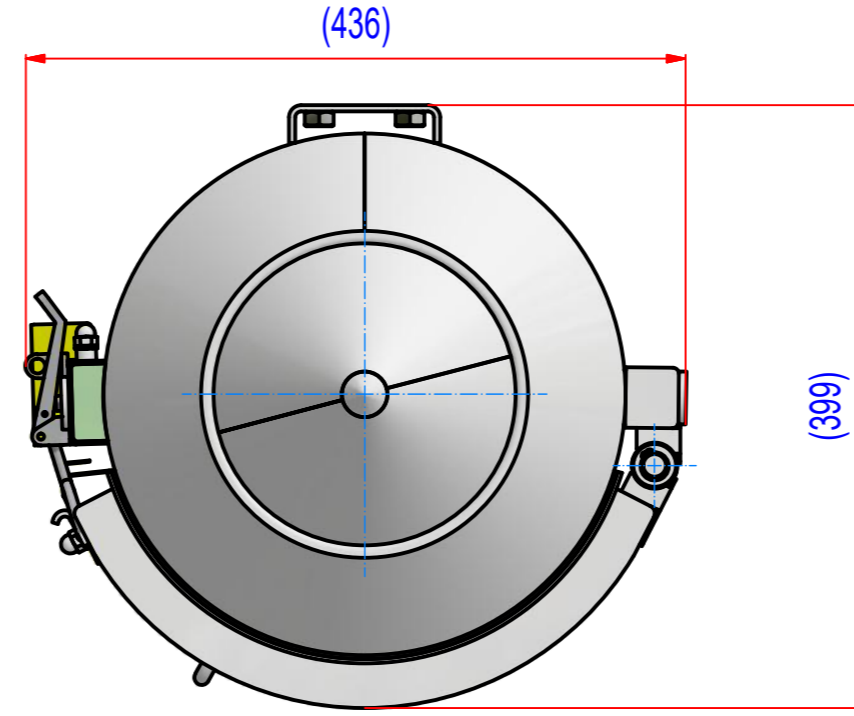
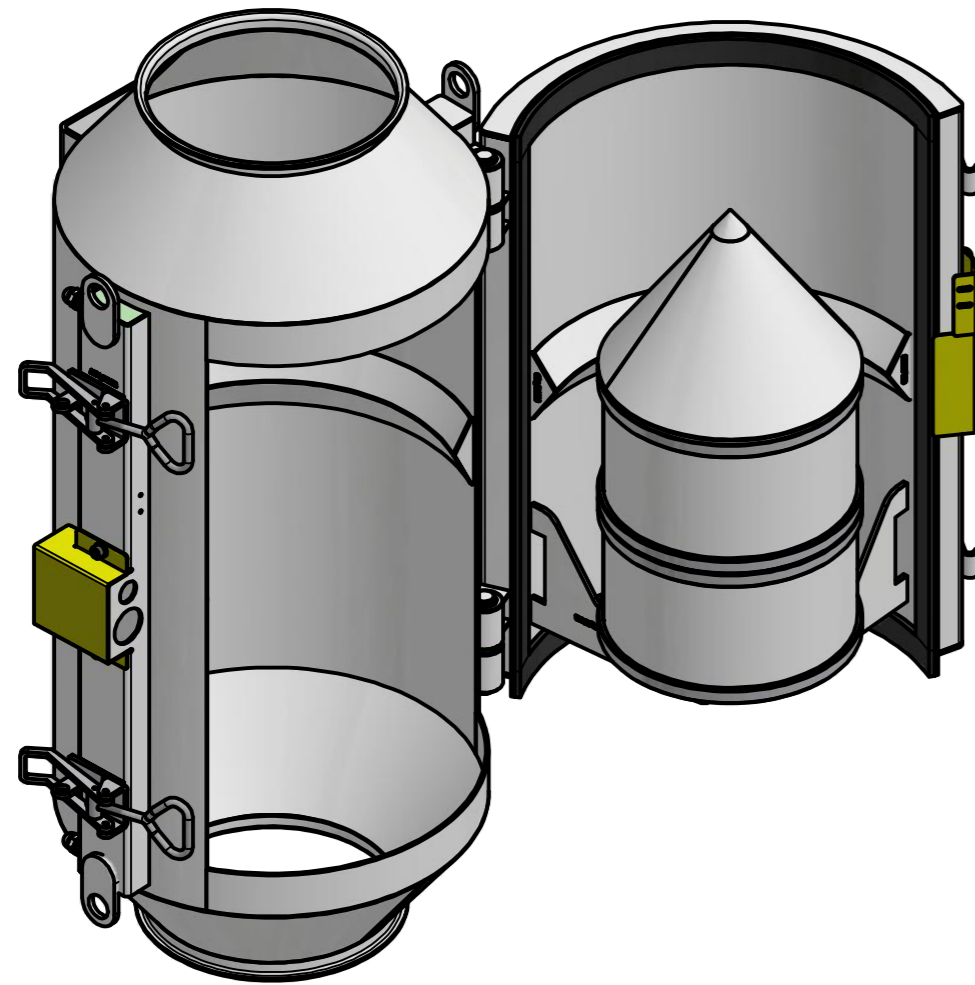
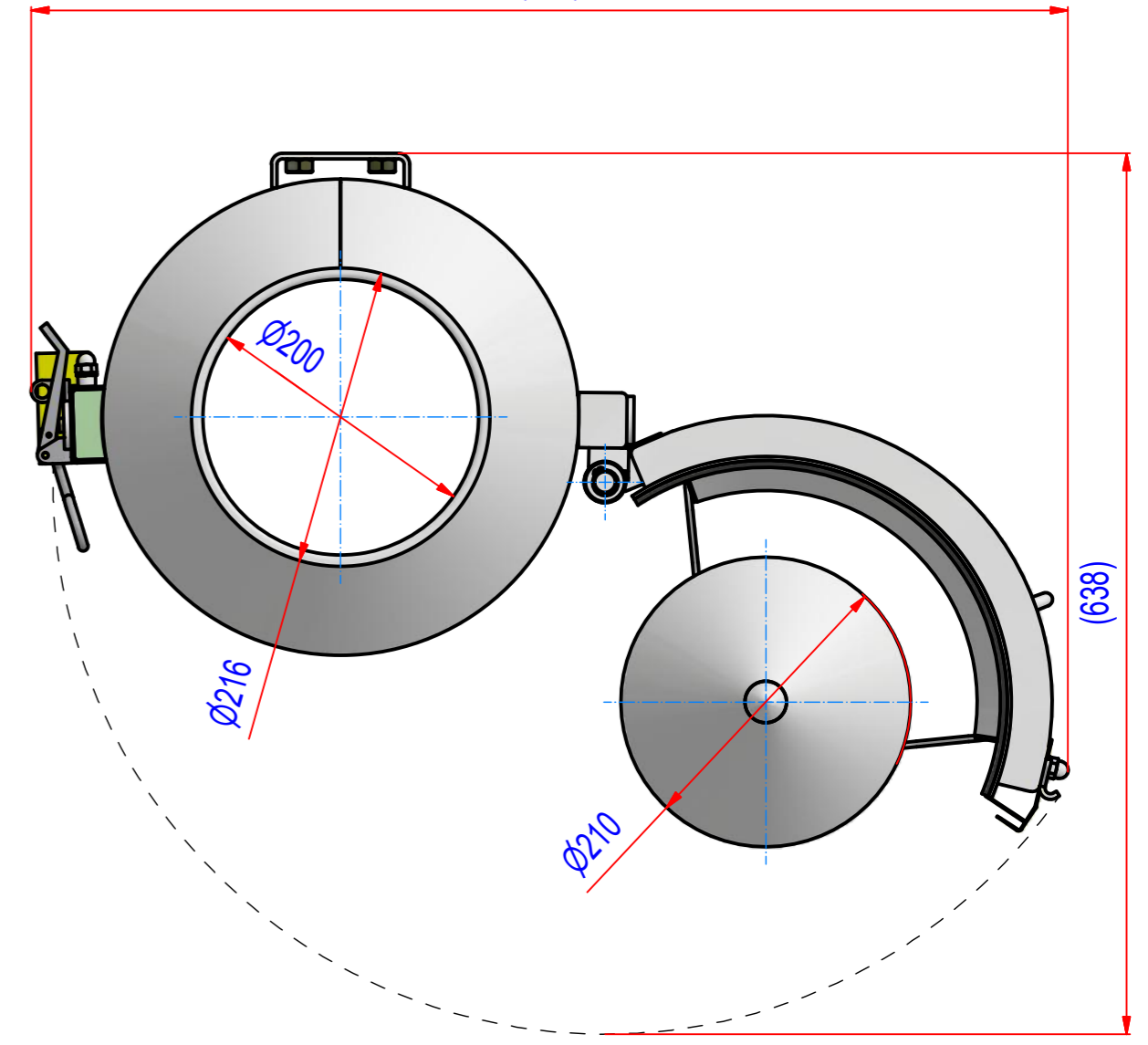

POZ./POS.	Č. SOUČÁSTI/ PART NUMBER	POPIS / DESCRIPTION	HMOT./ WEIGHT
1	A048_000000	SPPE010162	73,2
Sheet: A2 Drawn: PW Date: 08.02.2017 Predecessor: SPPE000162 Quick search: XSPP 2 Description: Pipe magnet, ferrite, PM2, type E, JACOB		Extra info: © All rights reserved. Reproduction is not permitted without written permission of GOUDSMIT Magnetic Systems BV	General tolerance: ISO 2768 - cL Drawn according: ISO268; ISO1101; ISO2553 Status: Customer reference number: Product key: SPP-2-TC-FJ-S4-B-BB Part number: SPPE010162 Rev: