

REV	BY	DATE	DESCRIPTION
-	PW	27.07.2018	New Vault, nothing changed, old rev.B

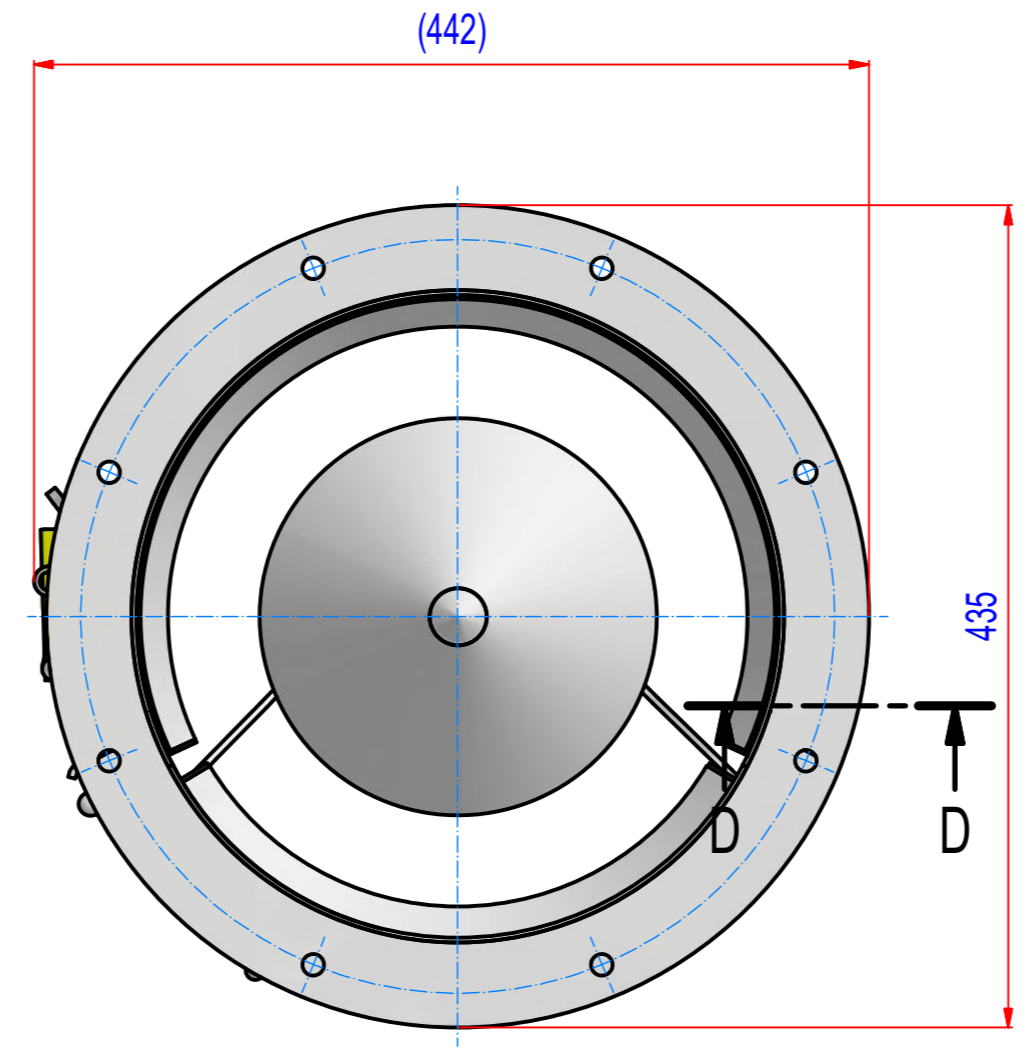
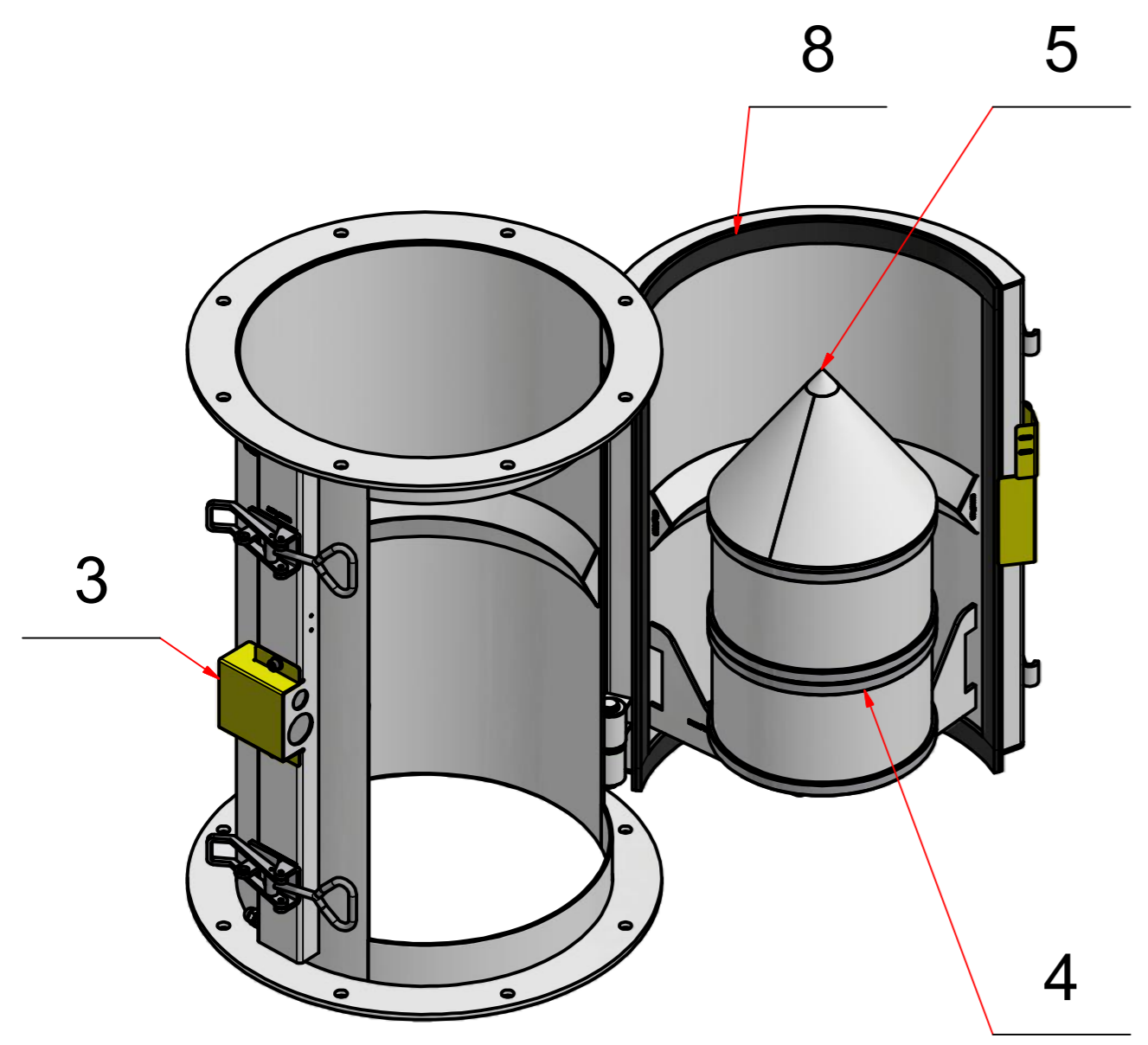
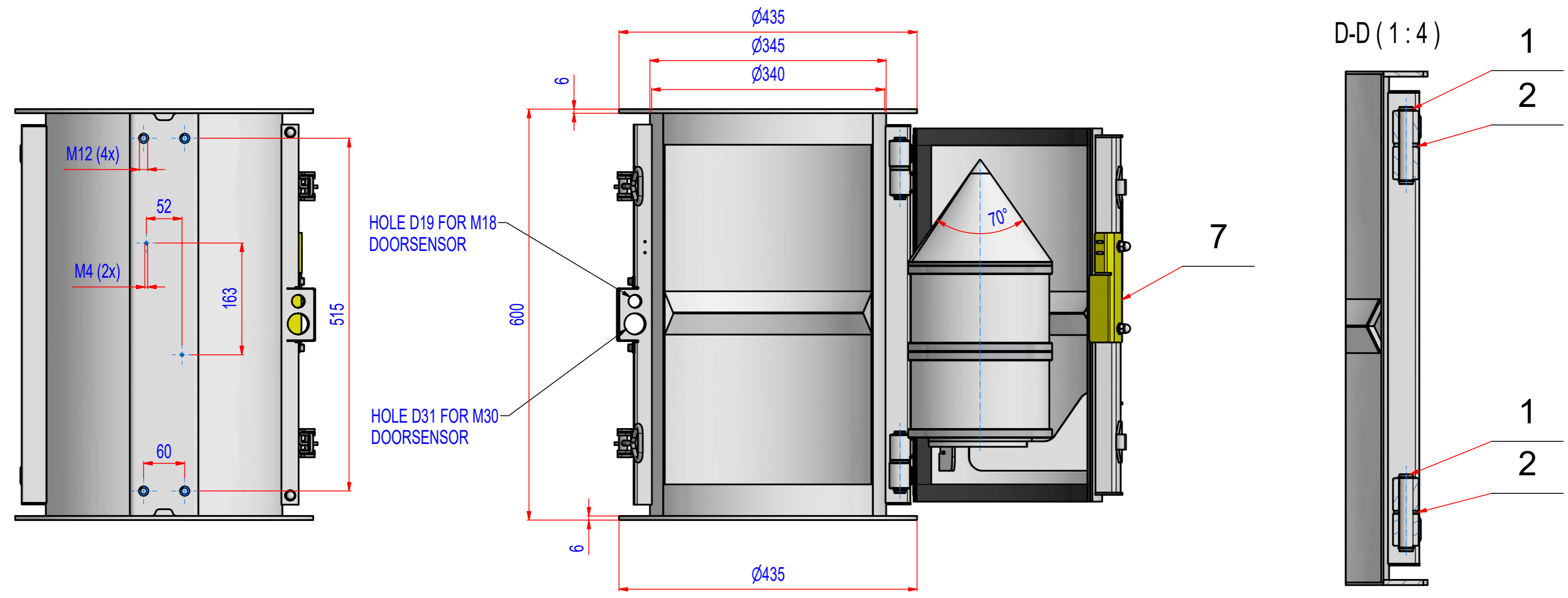

POZ.	Č. SOUČÁSTI	POPIS	MATERIÁL	HMOT.	MN.
8	A004_000001	Gasket PM2; 25x5, L=1870mm	Silikon	0,3	1
7	G37_000003_B	Sensor plate	AISI304	0,1	1
6	G37_020003	Slide pad magnet PM2		0,1	1
5	G37_030300	Cone for PM2 70 st	AISI304	2,2	1
4	H54_030000	Magnet core for PM2 - 60°		42	1
3	G32_010302	Cover for sensor	AISI304	0,1	1
2	G80_010007	Washer wear PM1	POLYAMID	0	2
1	G80_010006	Hinge pin for PM1	AISI304	0,1	2

Sheet: A2	Extra info:	General tolerance: ISO 2768 - cL
Drawn: PW	Weight (kg): 75	Drawn according: ISO268; ISO1101; ISO2553
Date: 27.07.2018		Status:
Predecessor:		Customer reference number:
Quick search: XSPP2	© All rights reserved. Reproduction is not permitted without written permission of GOUDSMIT Magnetic Systems BV	Product key: SPP-2-FC-FO-S4-B-BB
Description: Spare parts for SPPF000162		Part number: SPPF000162_SP