

REV	DATE	BY	DESCRIPTION
-	22-8-2022	AvD	REFERENCE DRAWING SRCC320101
A	8-12-2022	AvD	DRAWING CORRECTED

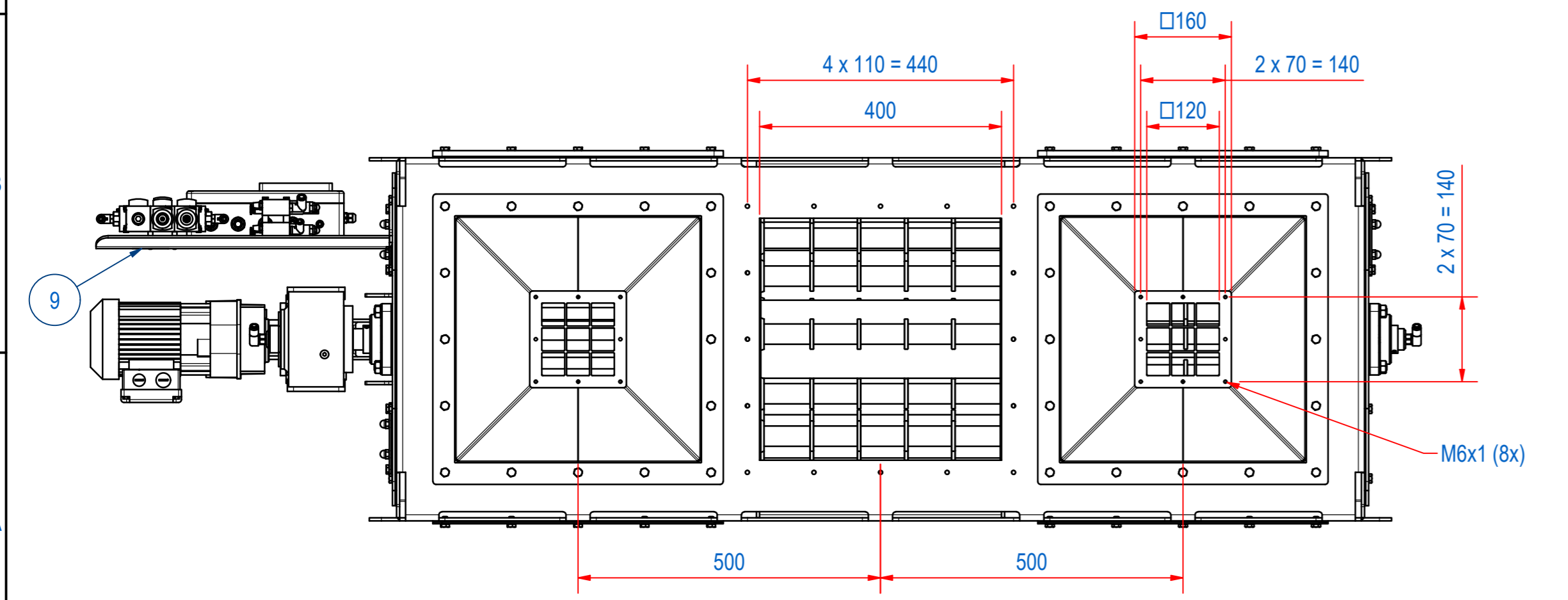
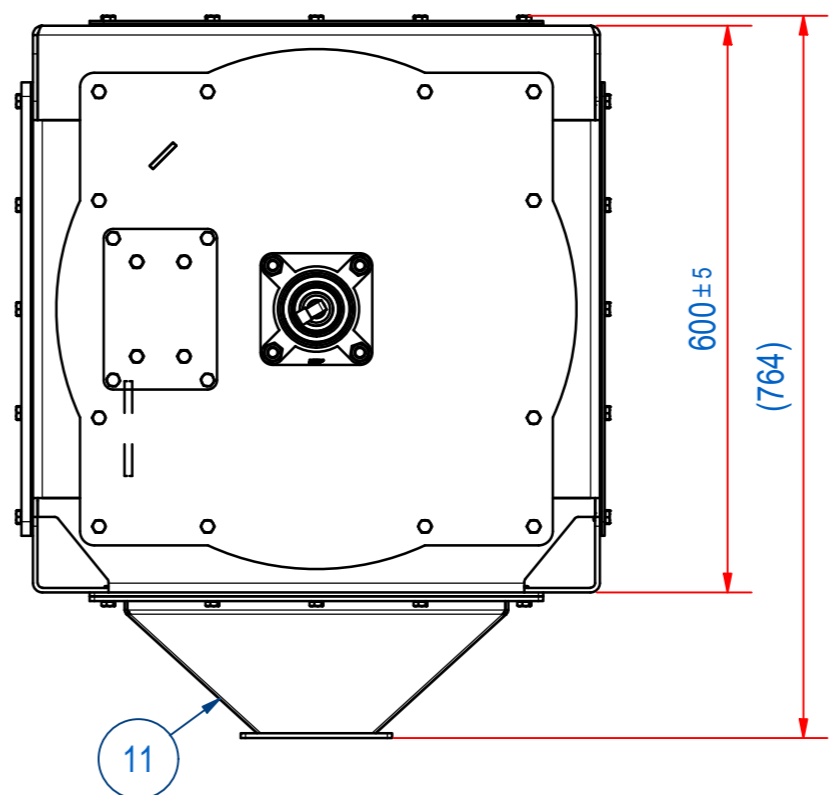
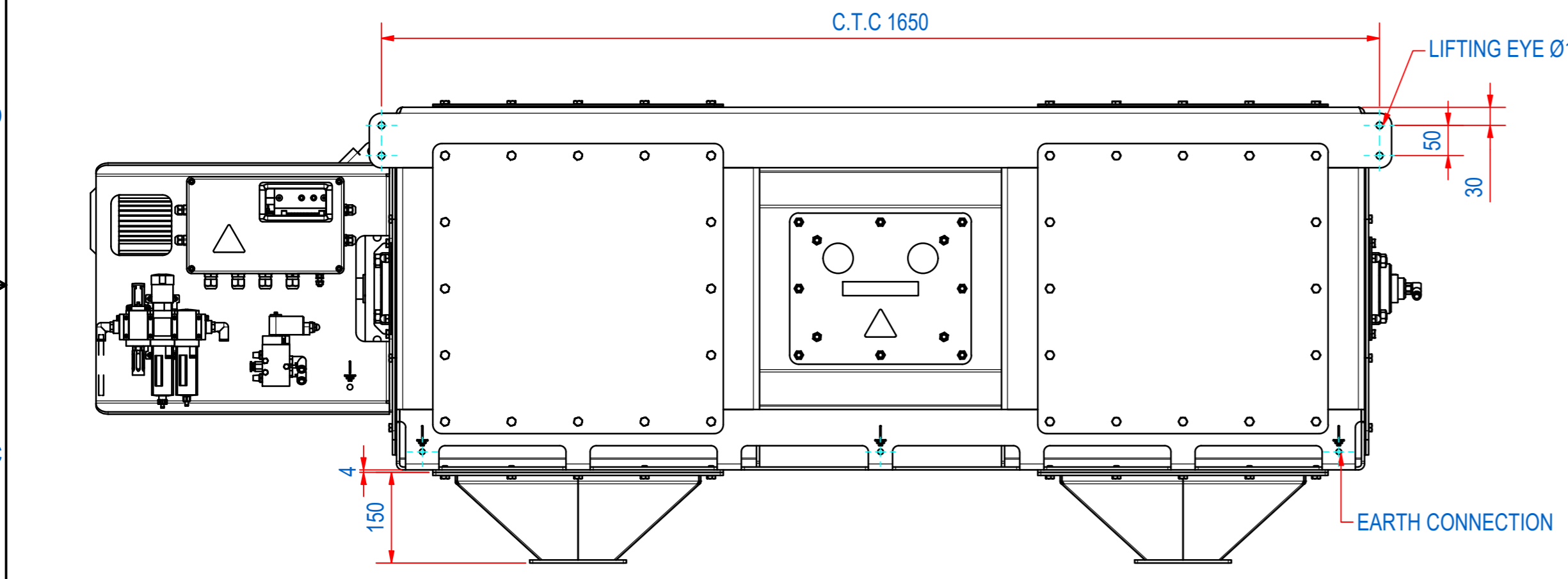
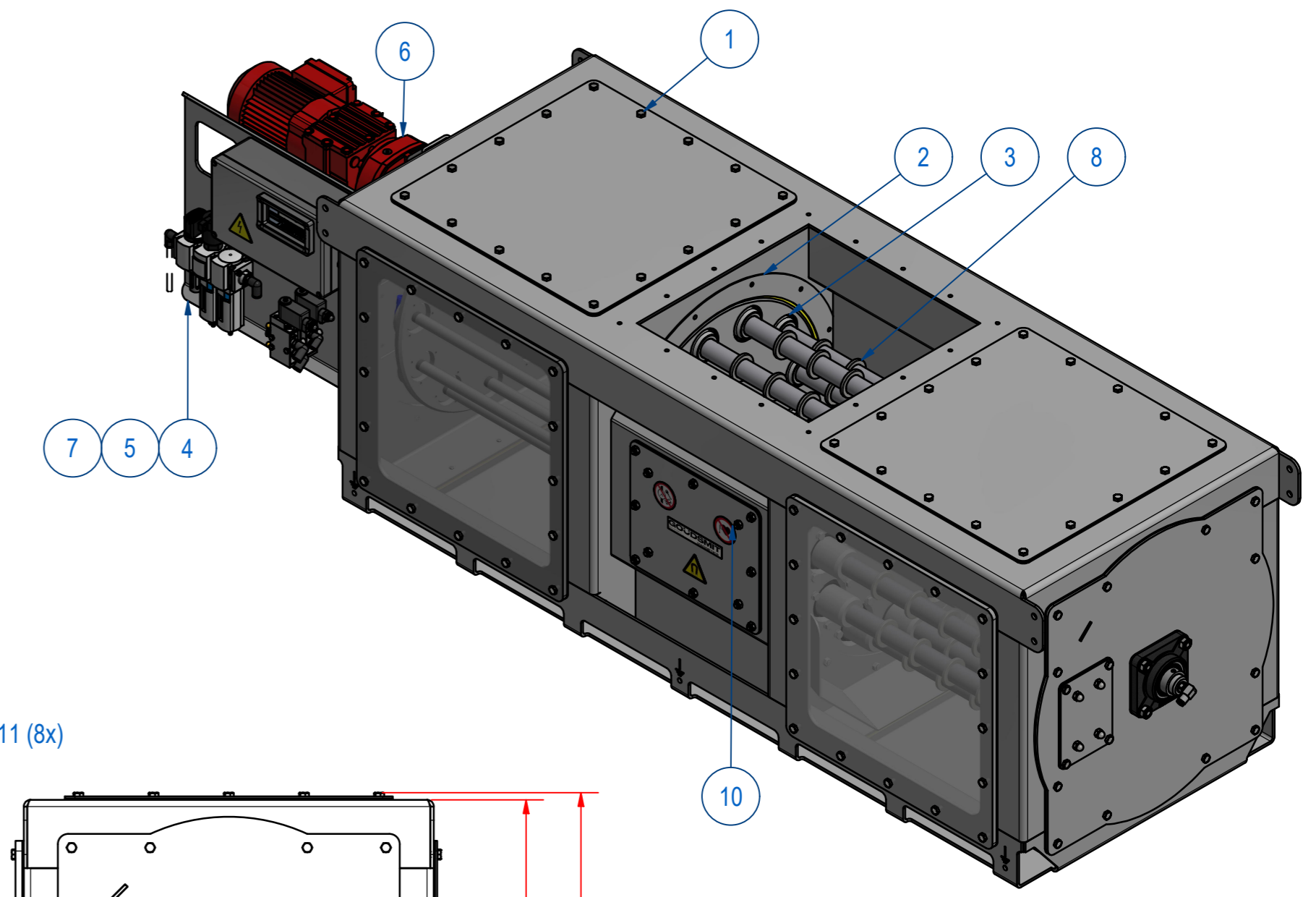
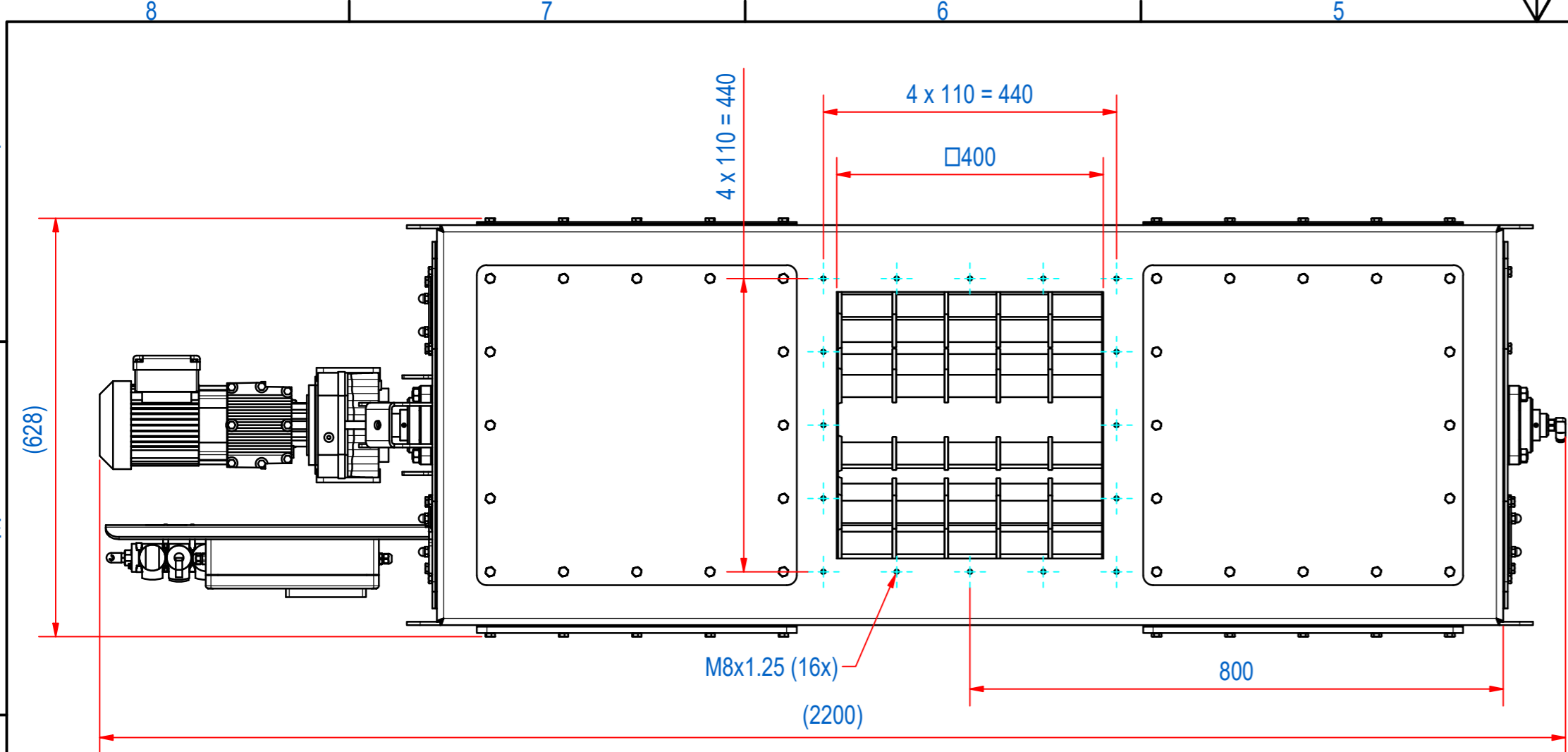

ITEM	QTY	PART NUMBER	DESCRIPTION	Dimensions
11	2	E0154443	SRCC-4040 REDUCER #120 H150	
10	1	E0141396	STICKERS FOR SRCC	
9	1	E0133462	TYPE PLATE SRCC NO ATEX	
8	11	SECC400916	SECC-S-400 MAGN ROD D34 NdFeB	
7	1	A120348	PNEU SCHEME Ex II3D T85°C RC000	
6	1	MH01200508	FA37/G R17II2GD EDRN63MS4/3D/AL 5RPM	
5	1	M25964	LOGO PROGRAM SRCC400	
4	1	E0068182	SRCC-CONTROL UNIT Ex	
3	1	E0065898	ROTOR ASSY RC4040	
2	2	E0066060	SRCC-4040 INNER RING ASSY	
1	1	E0154441	SRCC-4040 HOUSE+COVERS	

RAW MAT.	Quantity	Material Number	Material Description	Length (mm)	Width (mm)
1	1				

Sheet: A2	Extra info: CLEANFLOW MAGNET ROTATING	General tolerance: ISO 2768 - mK
Drawn: AvD	Weight (kg): 445	Drawn according: ISO268; ISO1101; ISO2553
Date: 22-8-2022		Status: Released
Spare part: False	Source:	Customer reference number:
Quick search: SRCC4040		
Description: SRCC-4040-11S-N-NA-F1H-L-B-F	Document number: SRCC400101	Doc.Rev: A
	Part number: SRCC400101	Rev: A