

REV	BY	DATE	DESCRIPTION
A	LF	18.06.2017	ORIGINAL DRAWING
B	PH	19.03.2020	SMALL TECHNOLOGICAL CHANGE
C	LF	08.01.2021	DRIVE CLASS. IE3 (WAS IE1)

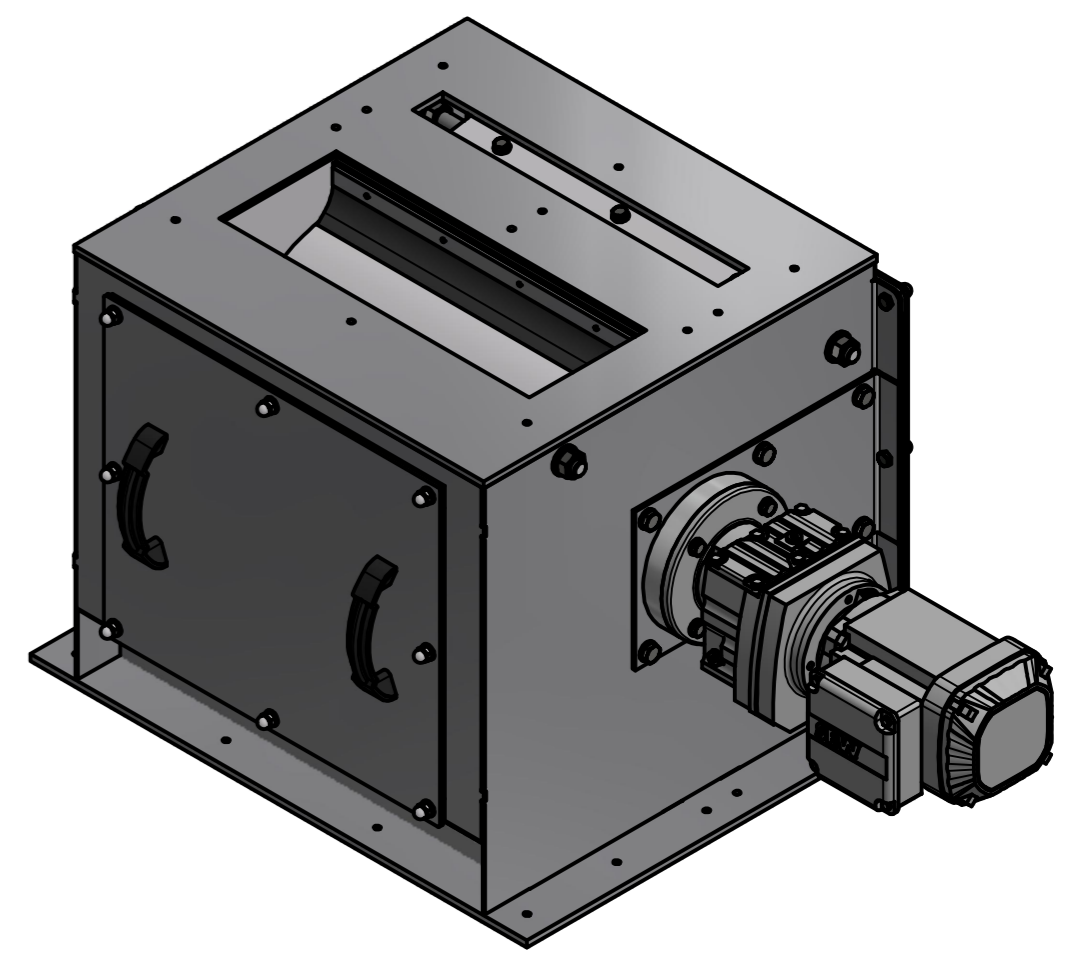

- GEARED BOX SEW RF37DRN71M4, i=55,76 (25RPM)

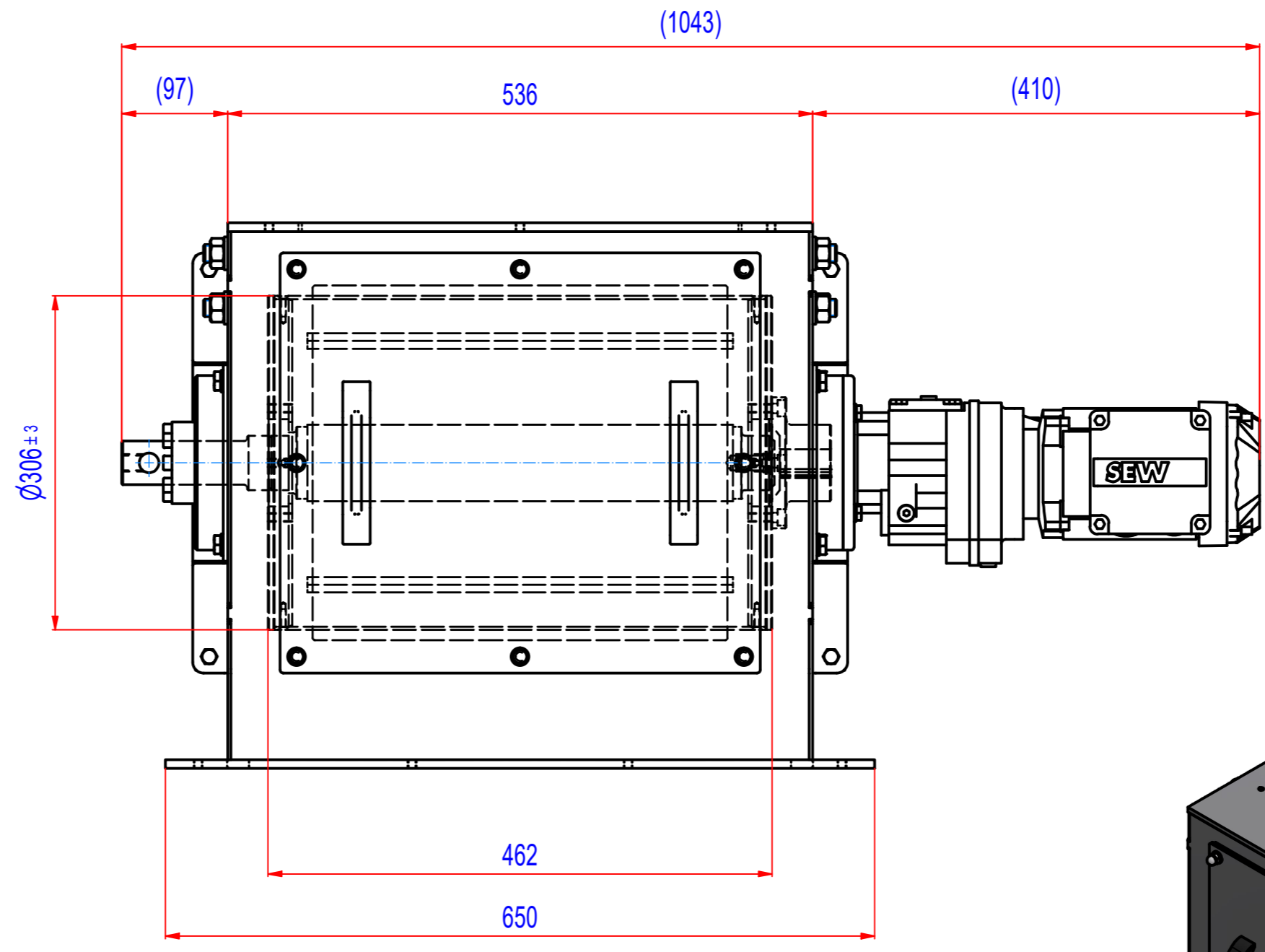
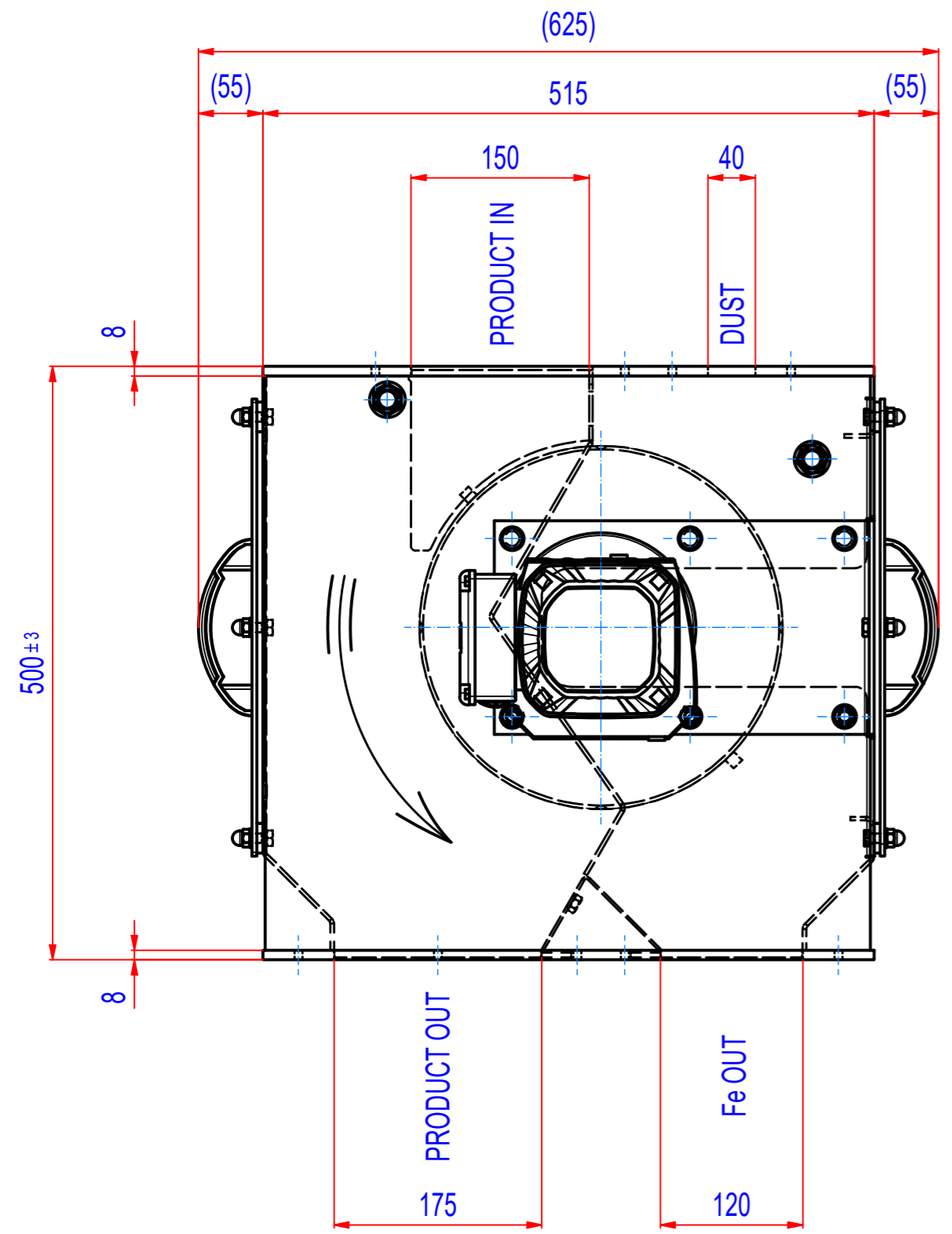
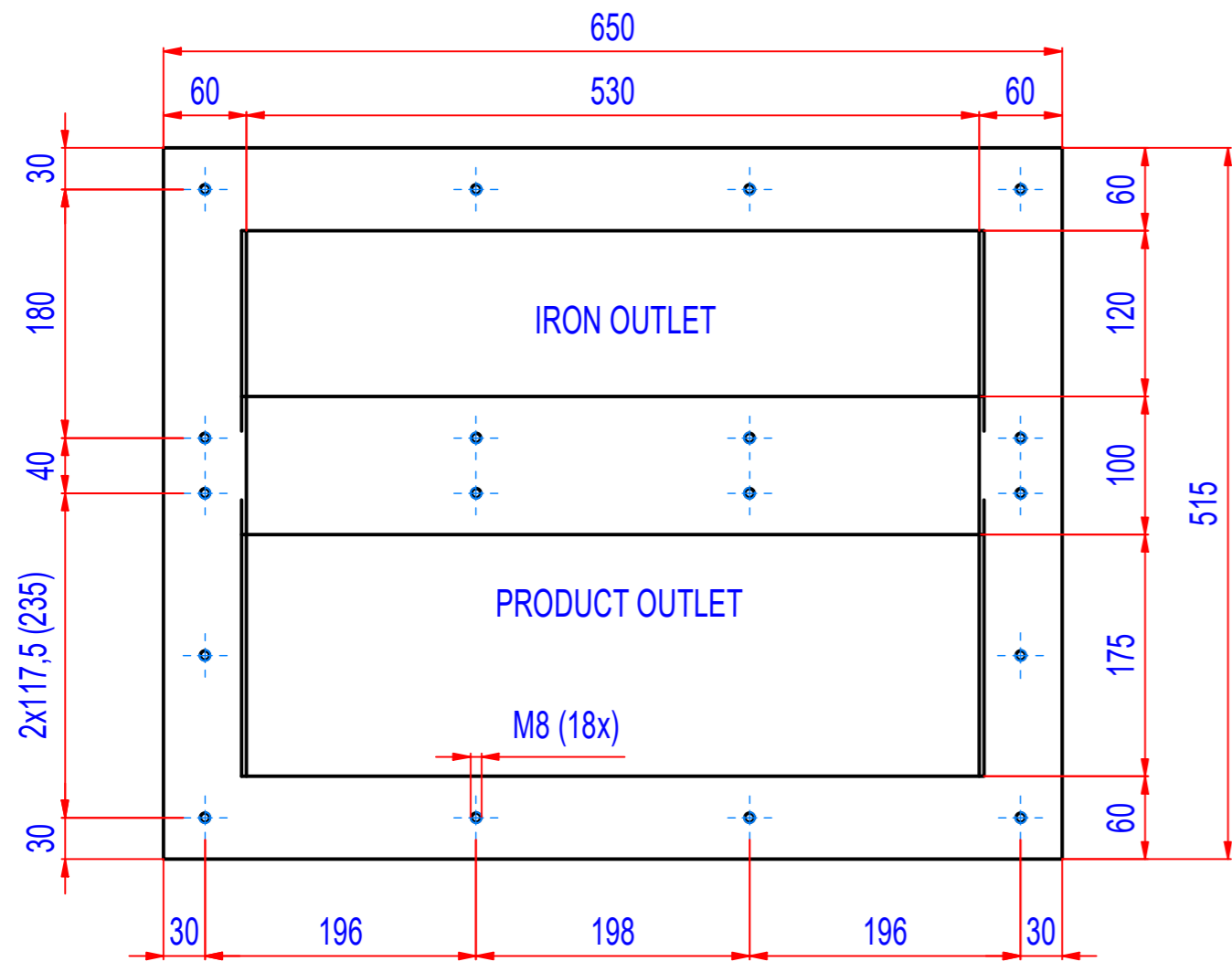

BOTTOM FLANGE

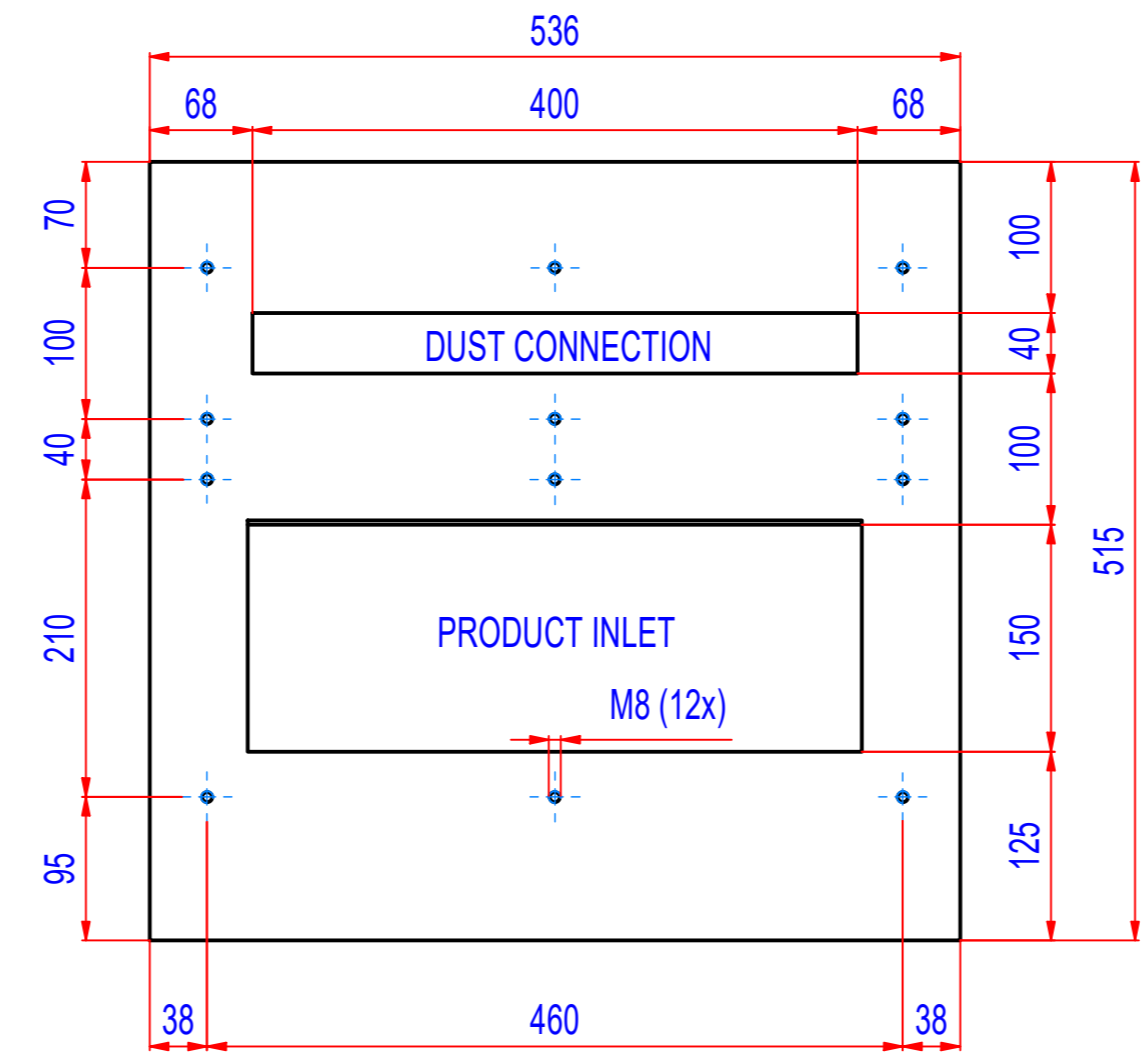

TOP FLANGE

1	A171_000000	SRTK040034	161
POZ./POS.	Č. SOUČÁSTI/ PART NUMBER	POPIS / DESCRIPTION	HMOT./ WEIGHT
Date:	Order ref.:	Responsible person:	
Sheet: A2 Drawn: LF Weight (kg): 161 Date: 08.01.2021 Predecessor:	Extra info:	General tolerance: ISO 2768 - cL Drawn according: ISO268; ISO1101; ISO2553 Status:	
Quick search: XSTK D306			Customer reference number:
Description: Drum separator, Comb, D=306, W=400	<small>© All rights reserved. Reproduction is not permitted without written permission of GOUDSMIT Magnetic Systems BV</small>		Product key: SETK-043-SD-B-30S2-NA-FZB-B-B Part number: SRTK040034 Rev: C