

REV	BY	DATE	DESCRIPTION
-	LF	18.06.2017	ORIGINAL DRAWING
A	PH	4.11.2020	Add note + food slats
C	LF	08.01.2021	DRIVE CLASS. IE3 (WAS IE1)

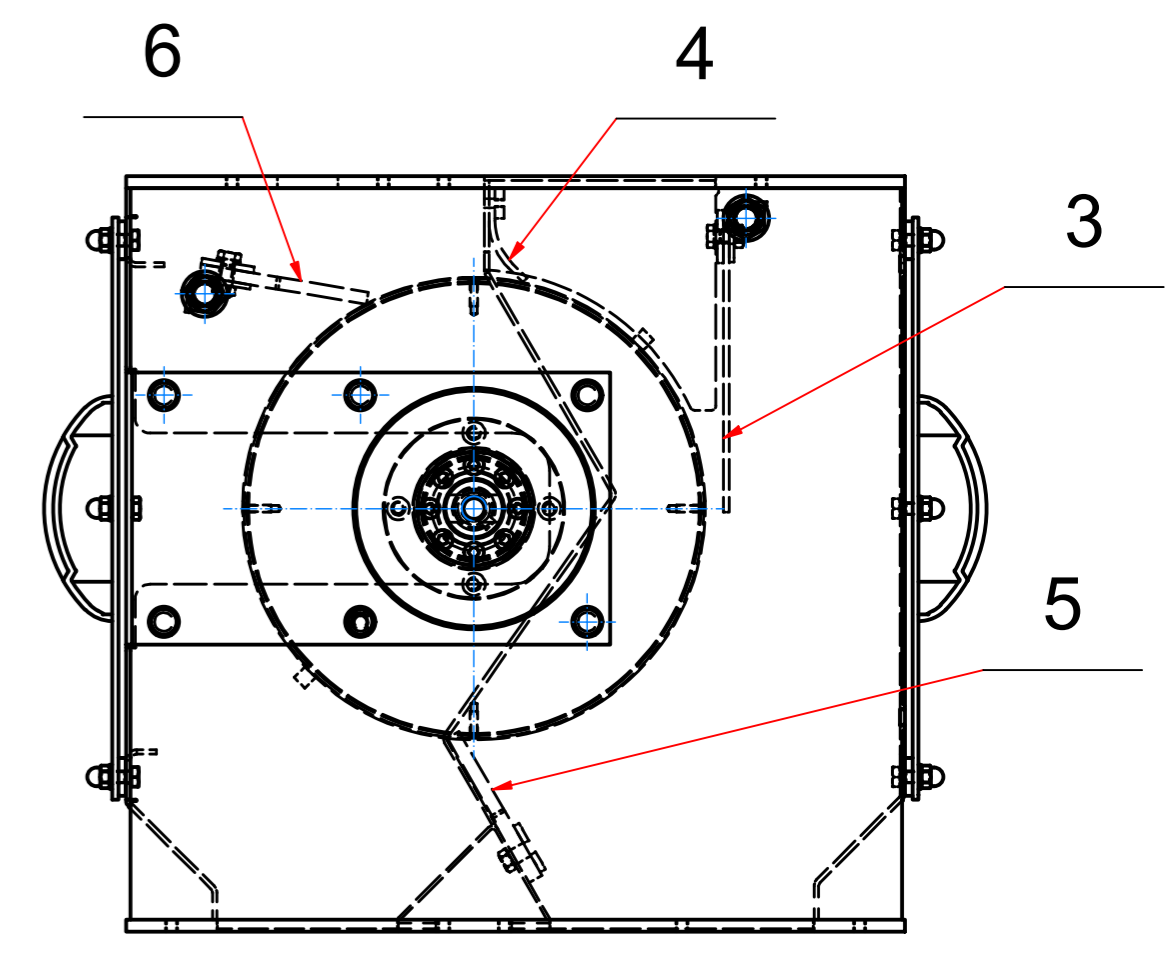

* It is recommended to replace the flanges (POS.10) and the drum shell (POS.1) at the same time.
The need to fit these parts.
Pos. 11 to 14 are intended for the food industry

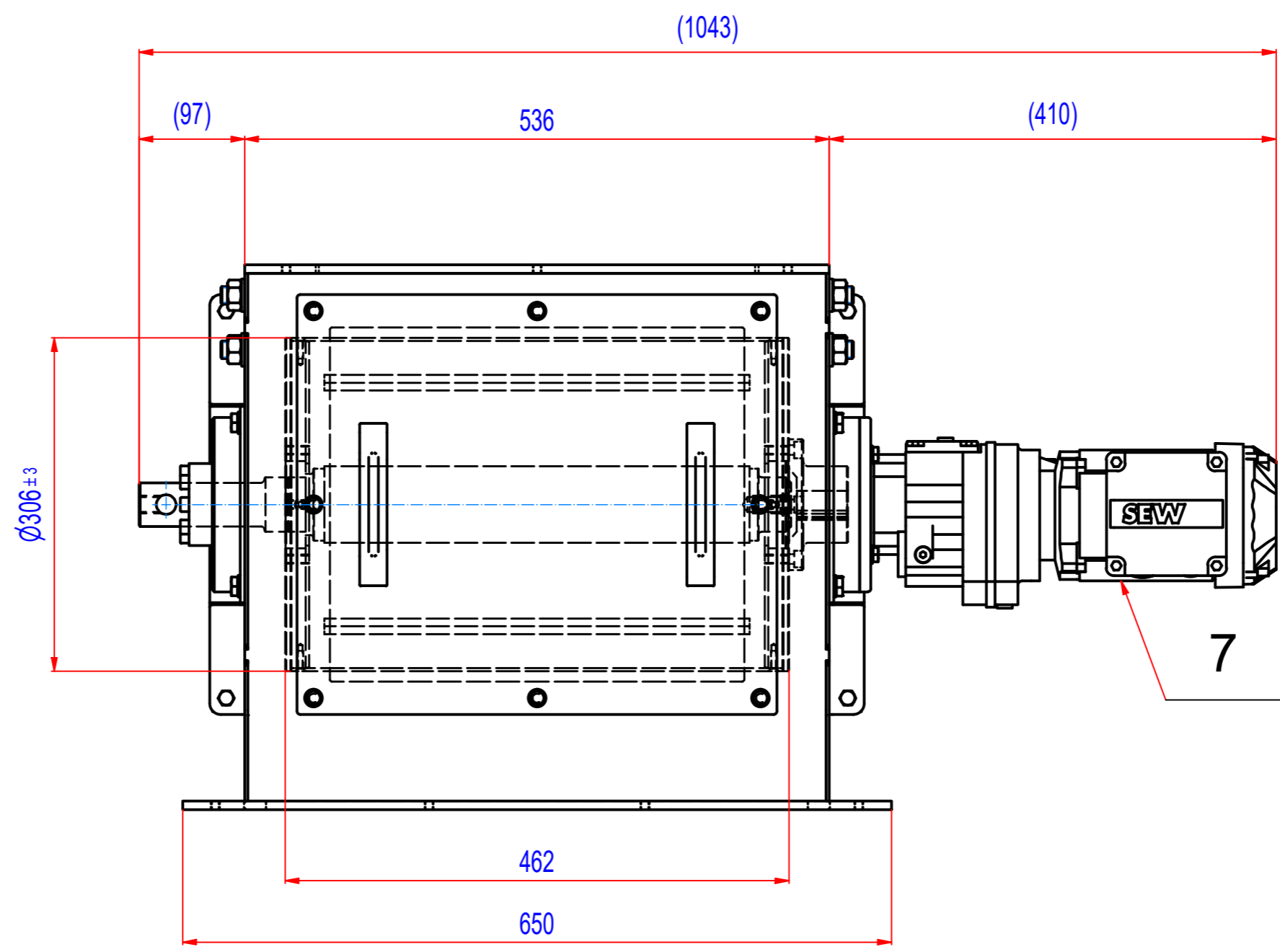
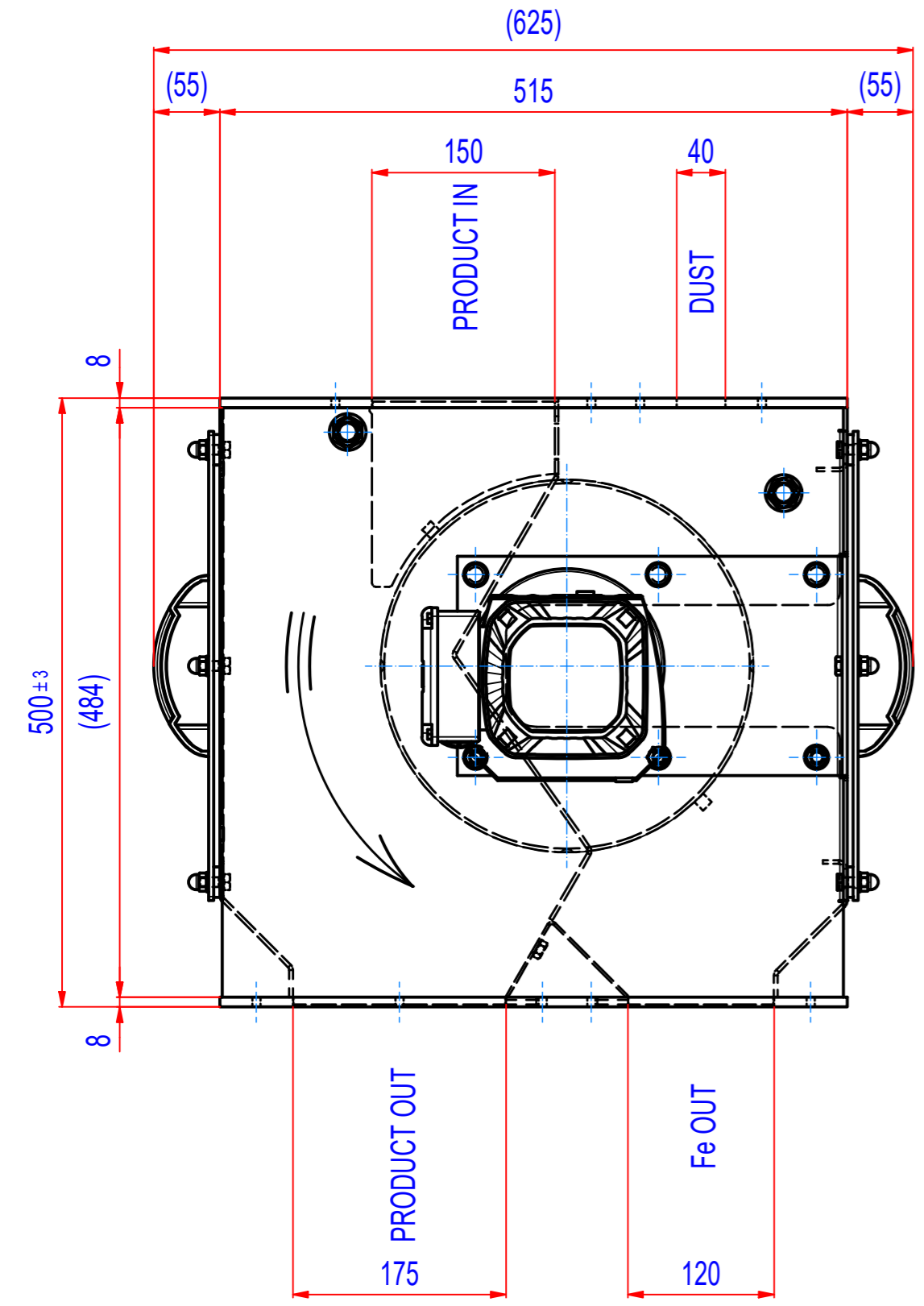
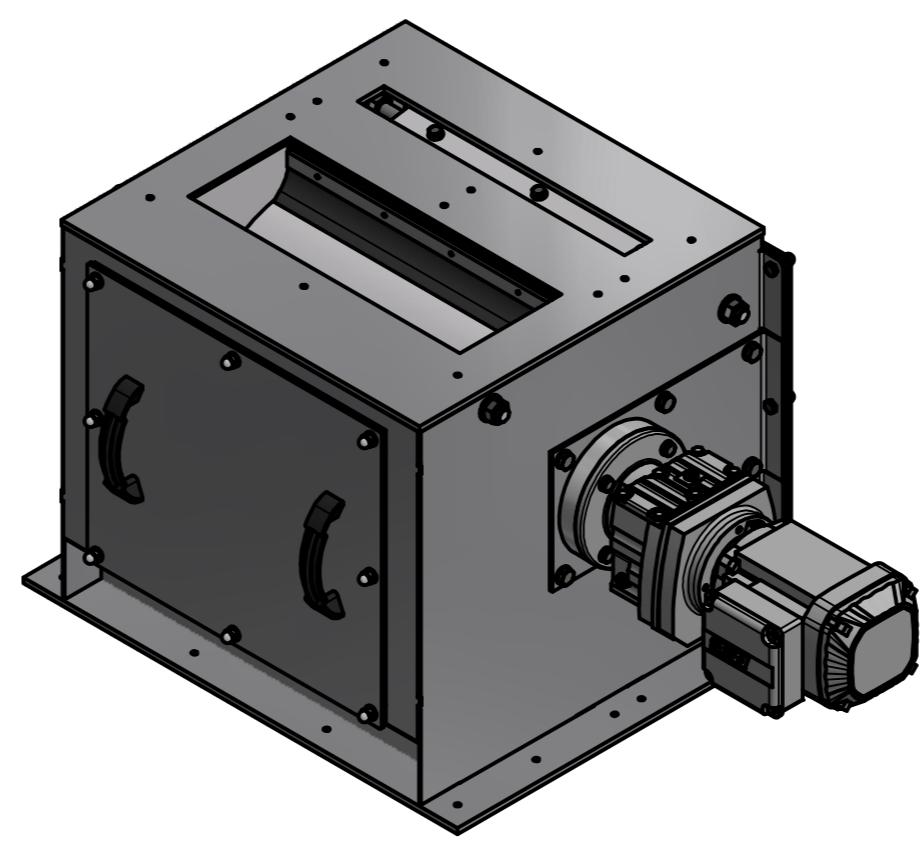
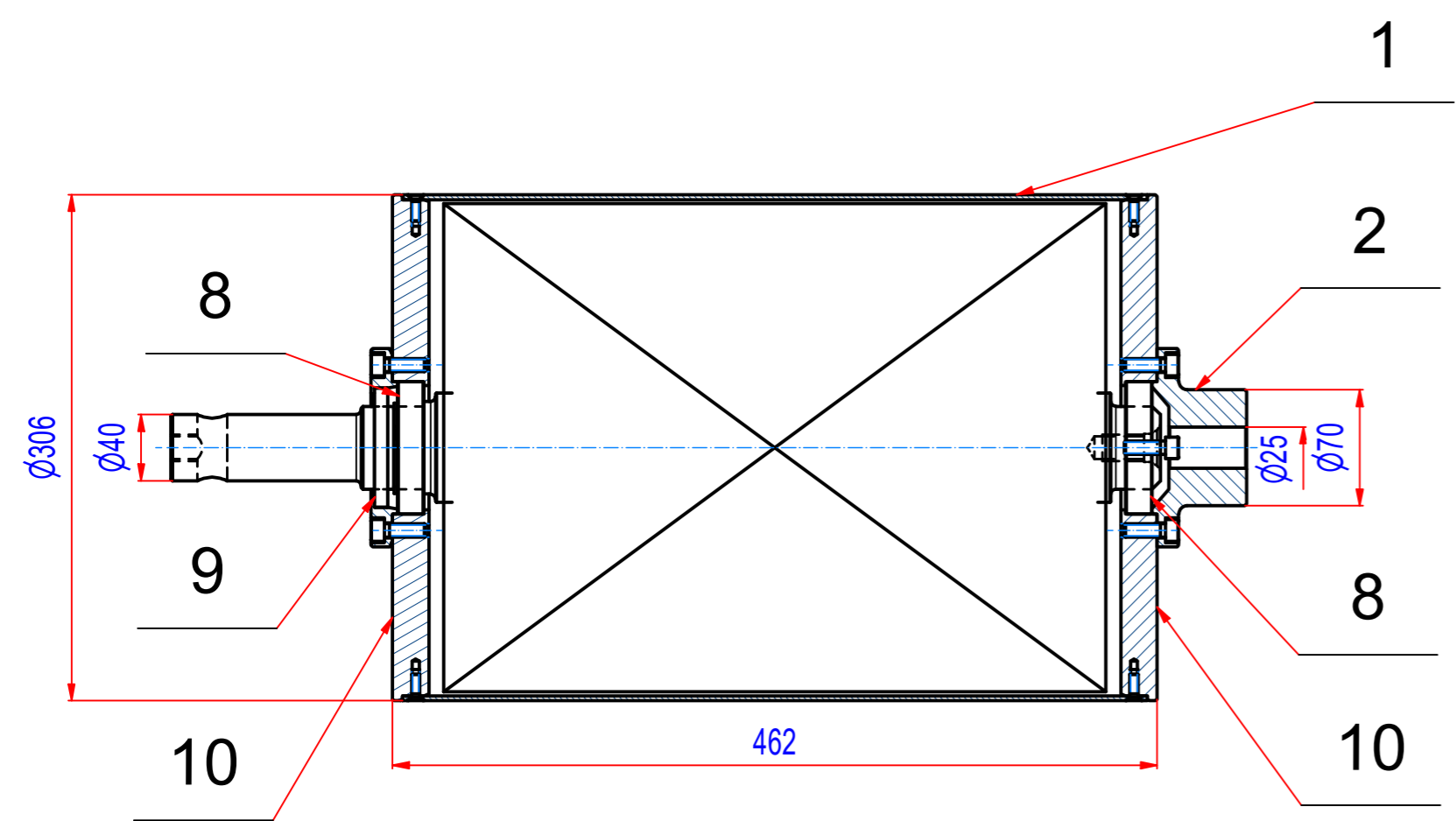

- GEARED BOX SEW RF37DRN71M4, i=55,76 (25RPM)

POZ.	Č. SOUČÁSTI	POPIS	MATERIÁL	HMOT. MN.
14	A171_050009	TOP CLEANING STRIP	FOOD PUR	0,3 1
13	A171_000009	BOTTOM CLEANING STRIP	FOOD PUR	0,5 1
12	A171_000008	INPUT PUR SLAT	FOOD PUR	0,1 1
11	A171_040009	FRONT PUR SLAT	FOOD PUR	0,3 1
10*	D02_020001	FLANGE SRTM080034	EN AW-6082 T6	4 2
9	74_1050082	SEALING RING NBR G 50x72x8	RUBBER	0 1
8	15_0406010	BEARING 6010-2RS1		0,2 2
7	MS037025019	DRIVE SEW RF37DRN71M4, 0,37kW, i=55,76 (25 RPM)		19 1
6	A171_050001	TOP CLEANING STRIP	PUR	0,3 1
5	A171_000001	BOTTOM CLEANING STRIP	PUR	0,5 1
4	C74_010012_B	INPUT PUR SLAT	PUR	0,1 1
3	C74_060005	FRONT PUR SLAT	PUR	0,3 1
2	819_000003	DRIVING SHAFT	S355 (11523)	2 1
1*	819_020000_B	SHELL OF SRTK040034	AISI304	11 1

Sheet: A2	Extra info:	General tolerance: ISO 2768 - cL
Drawn: LF	Weight (kg): 161	Drawn according: ISO268; ISO1101; ISO2553
Date: 09.01.2021		Status:
Predecessor:		Customer reference number:
Quick search: XSTK D306	© All rights reserved. Reproduction is not permitted without written permission of GOUDSMIT Magnetic Systems BV	Product key: SETK-043-SD-B-30S2-NA-FZB-B-B
Description: SPARE PARTS FOR SRTK040034		Part number: SRTK040034 Rev: C