

REV	BY	DATE	DESCRIPTION
	EN	27.04.2018	Nový Vault, reference SRTK060034w_E
A	LF	21.02.2021	MOTOR CLASS IE1 REPLACED BY MOTOR IE3

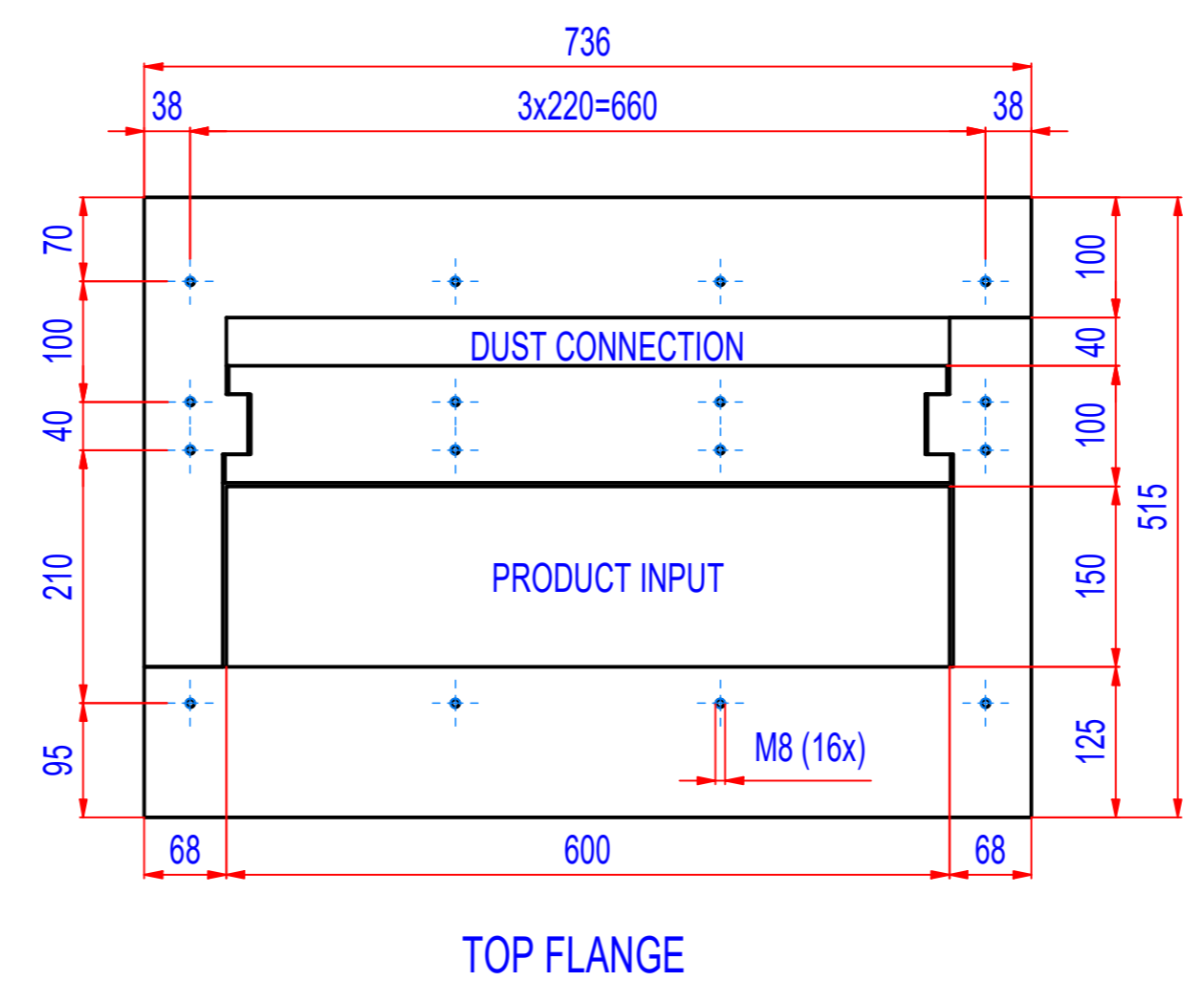
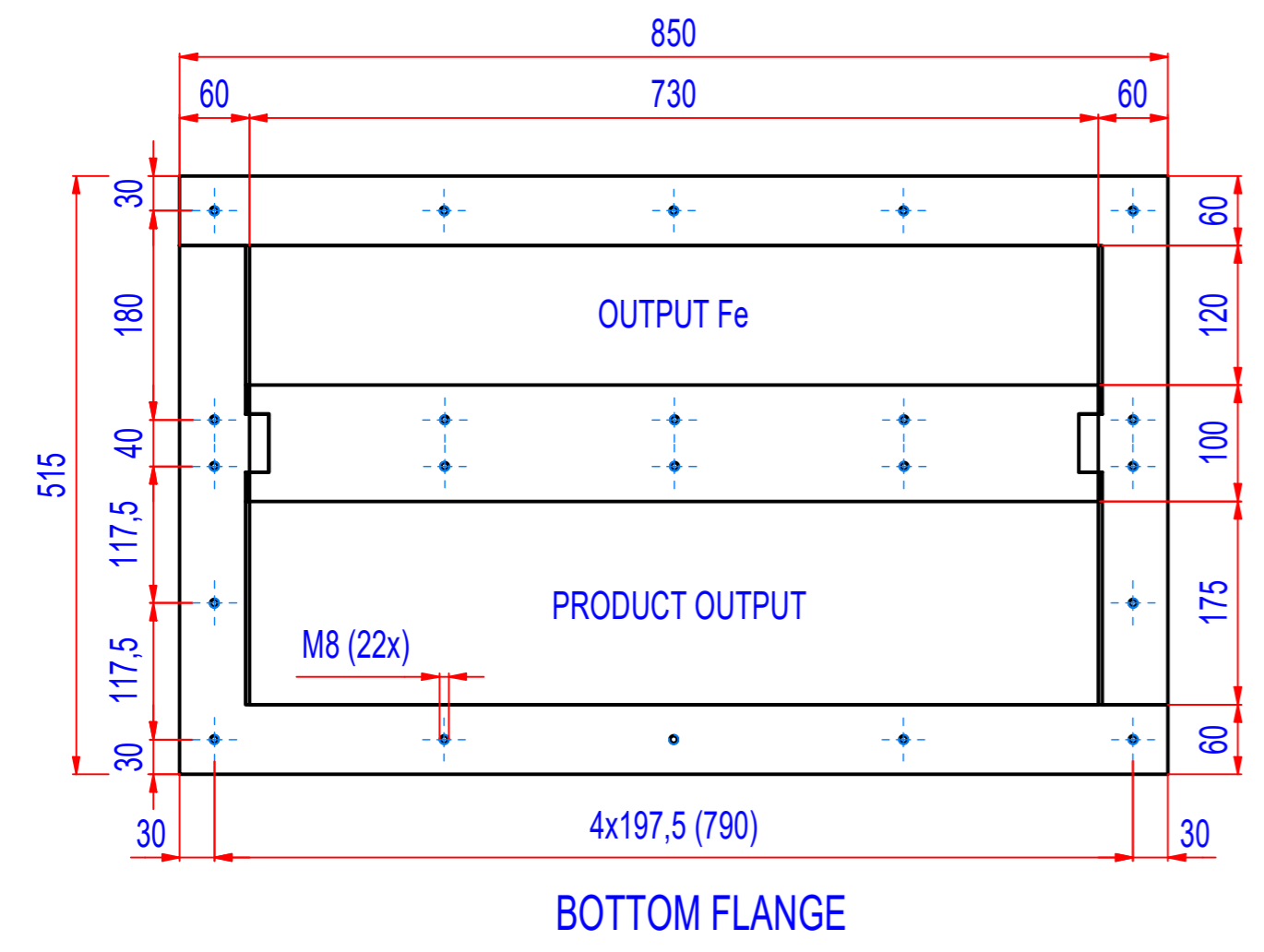
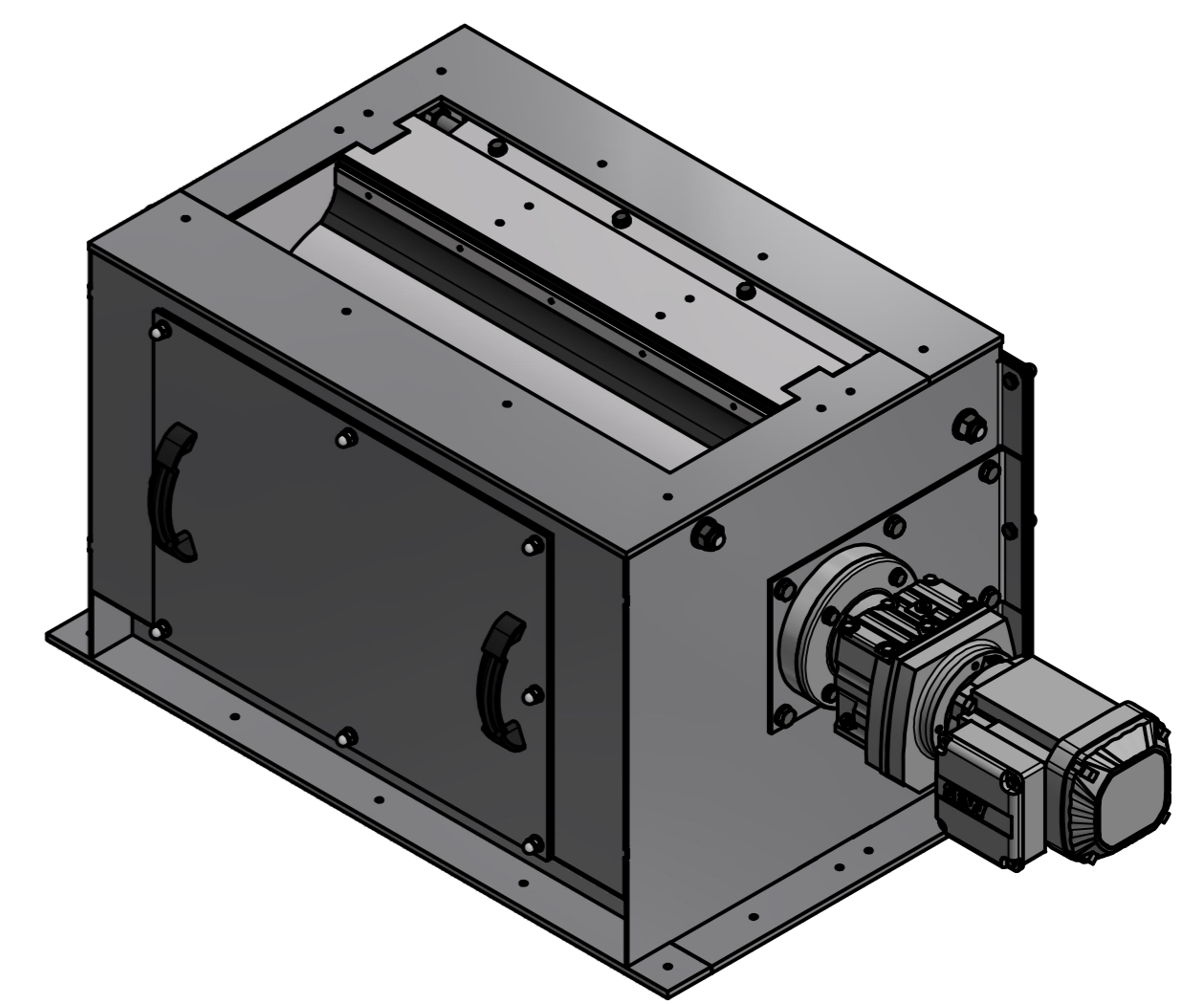
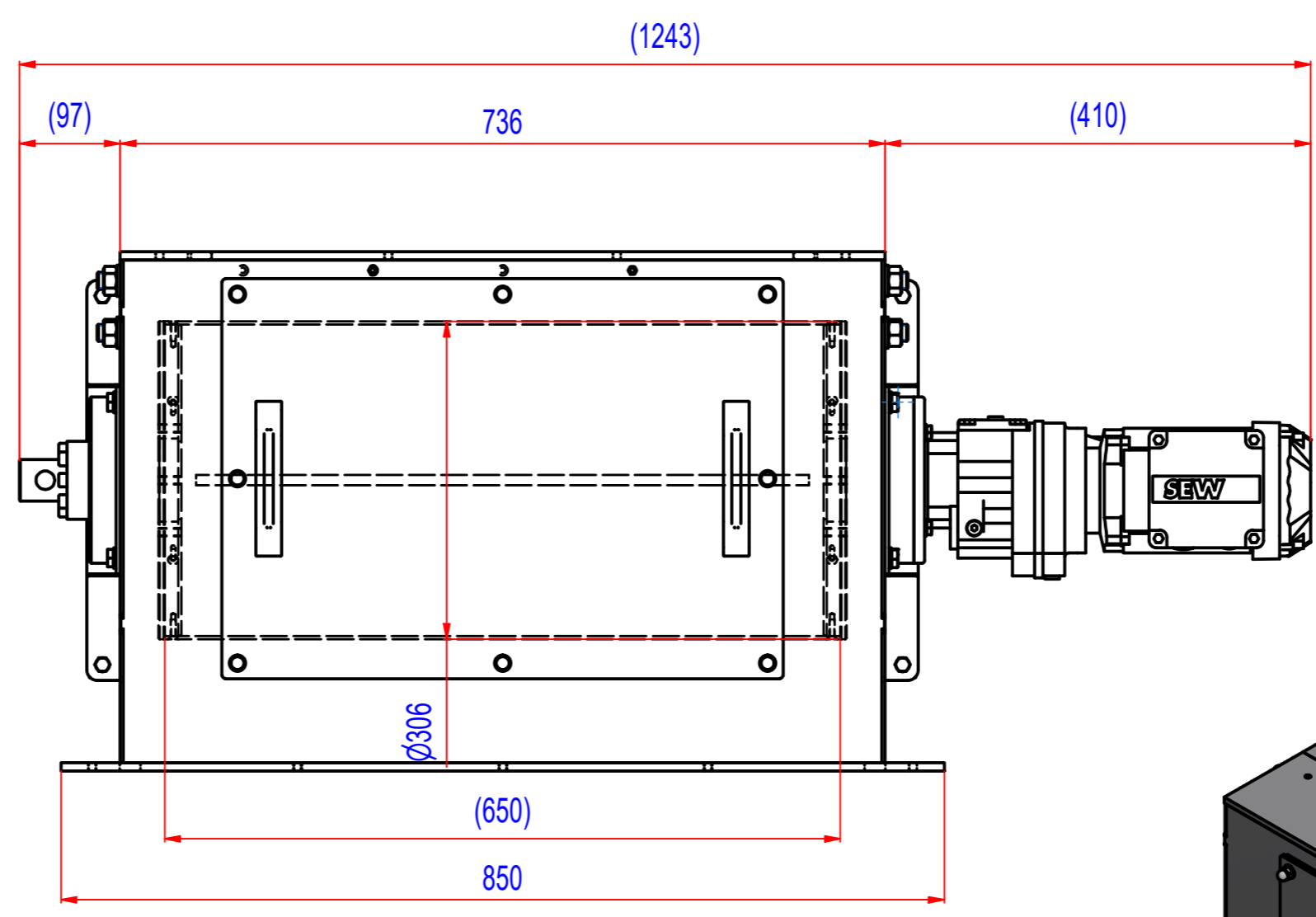
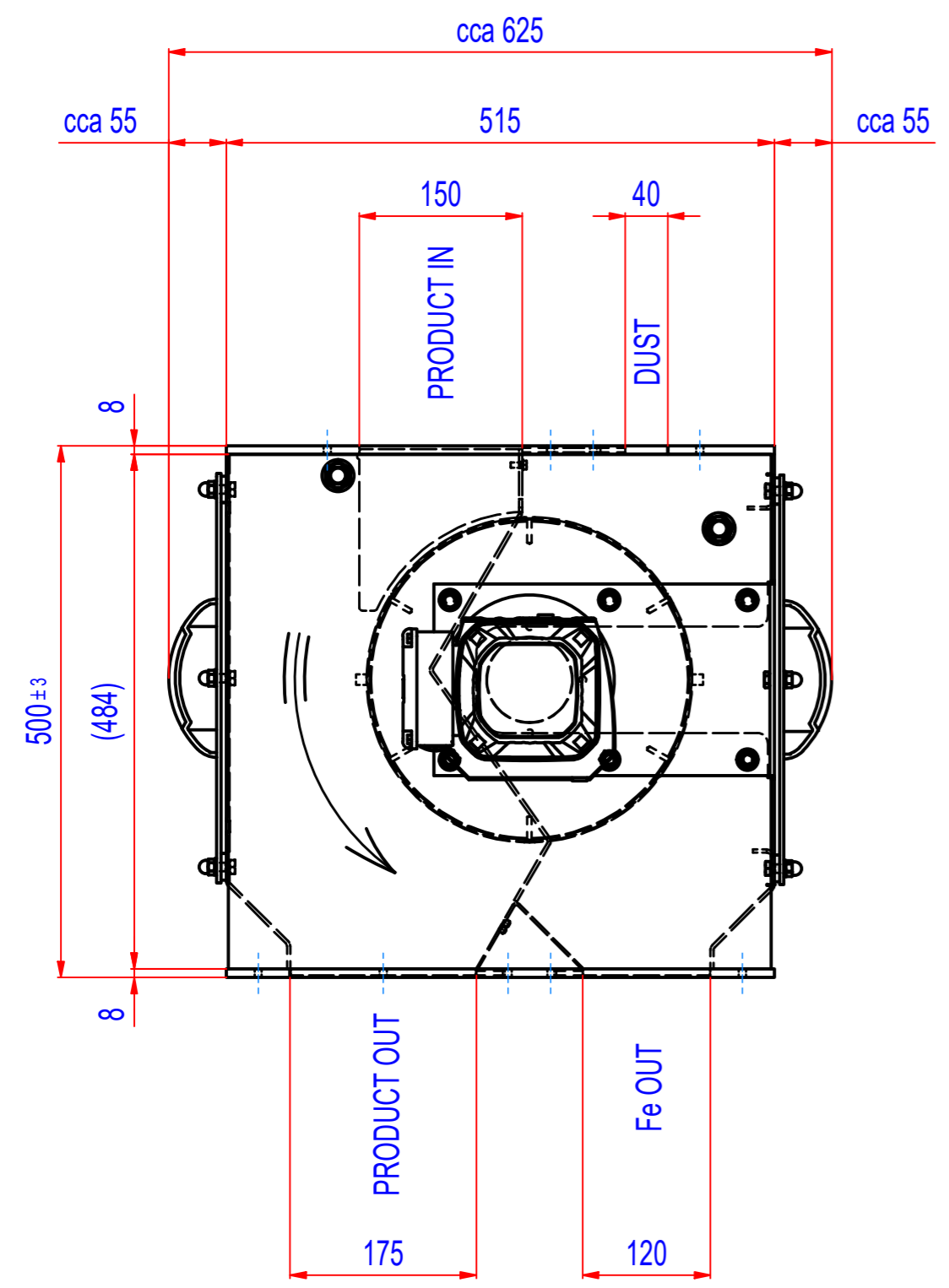

- GEARED BOX SEW RF37DRN71M4, i=55,76 (25RPM)

1	A442_000000	SRTK060034	214,4
POZ./POS.	Č. SOUČÁSTI/ PART NUMBER	POPIS / DESCRIPTION	HMOT./ WEIGHT
Date:	Order ref.:	Responsible person:	
Sheet: A2 Drawn: EN Weight (kg): 214,4 Date: 27.04.2018 Predecessor:	Extra info:	General tolerance: ISO 2768 - cL Drawn according: ISO268; ISO1101; ISO2553 Status:	
Quick search: XSTK		Customer reference number:	
Description: Drum separator in housing, Comb, D306, W600		Product key: SETK-063-SD-B-30S2-NA-FZB-B-B Part number: SRTK060034 Rev: A	