

REV	BY	DATE	DESCRIPTION
-	EN	27.04.2018	Nový Vault, reference SRTK060034w_E
	PH	05.11.2020	Add note + food slats
A	LF	21.02.2021	MOTOR CLASS IE1 REPLACED BY MOTOR IE3

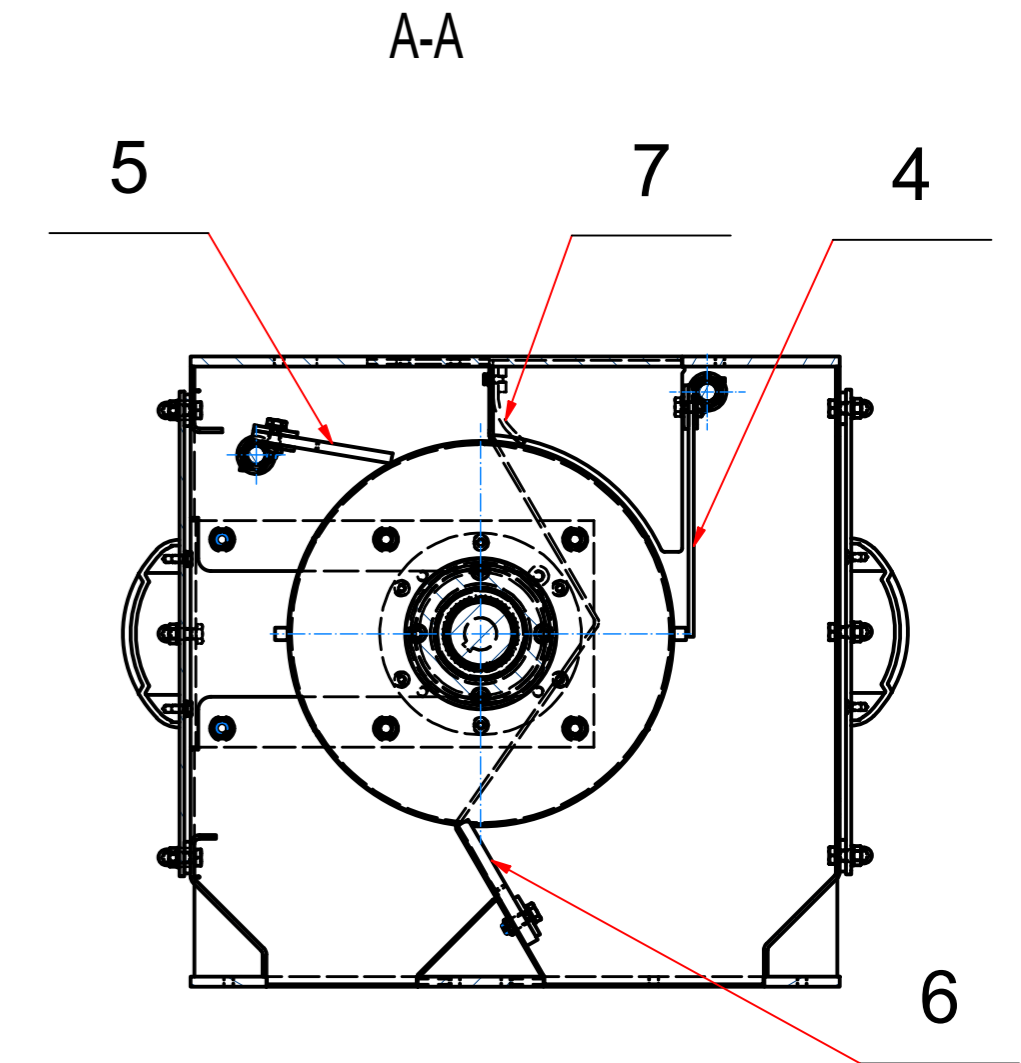

* It is recommended to replace the flanges (POS.10) and the drum shell (POS.1) at the same time.
The need to fit these parts.
Pos. 11 to 14 are intended for the food industry

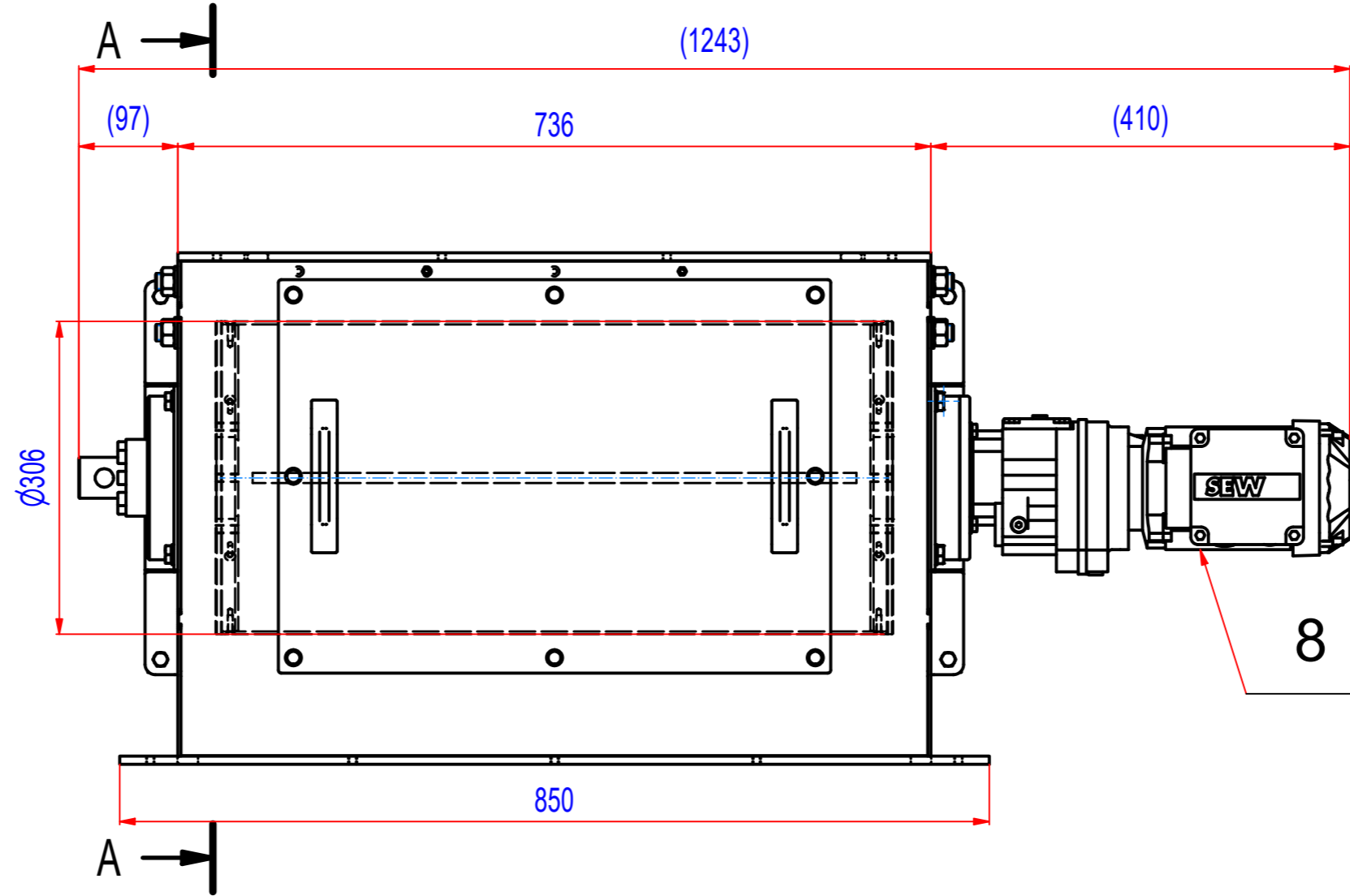
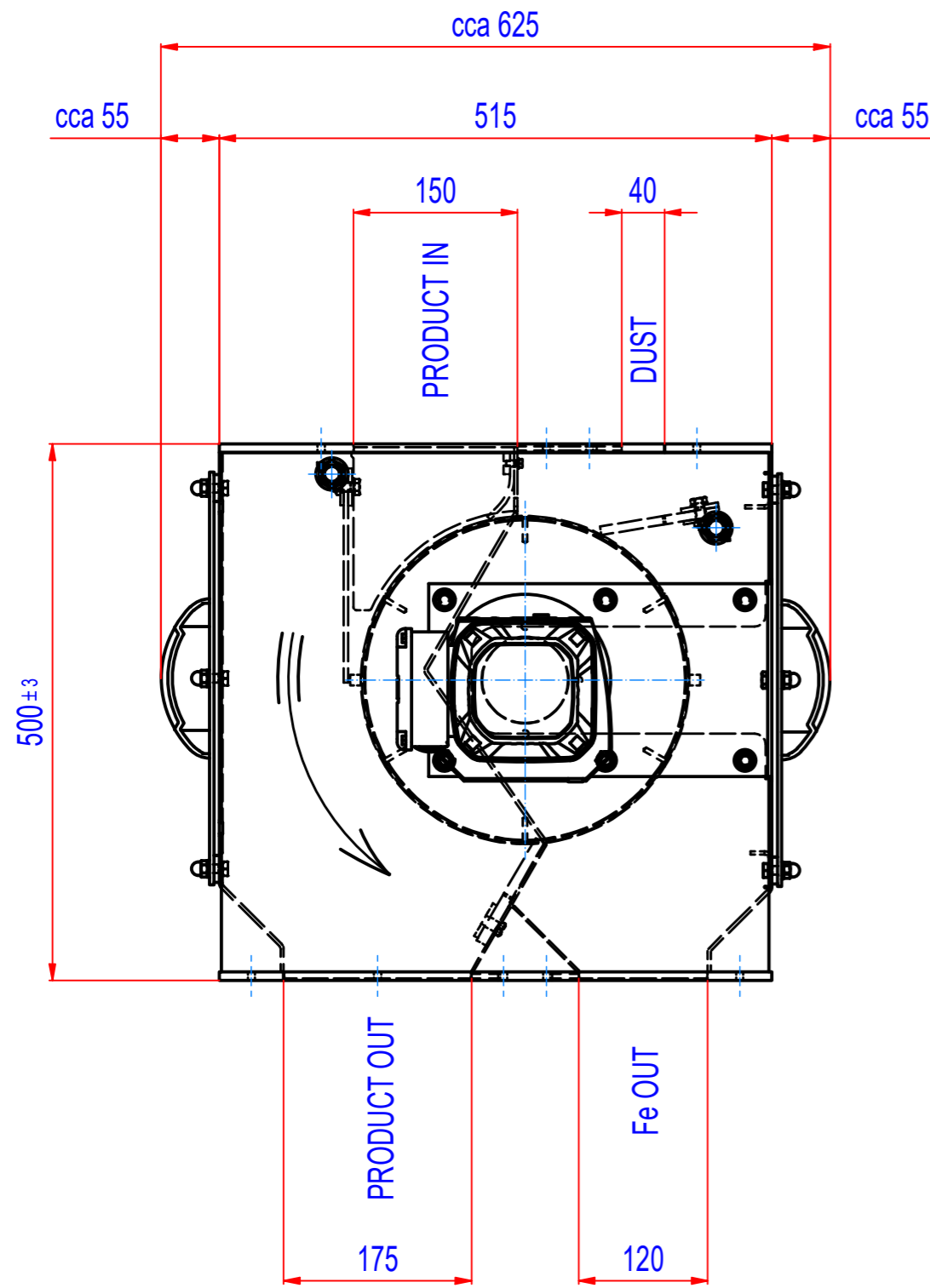
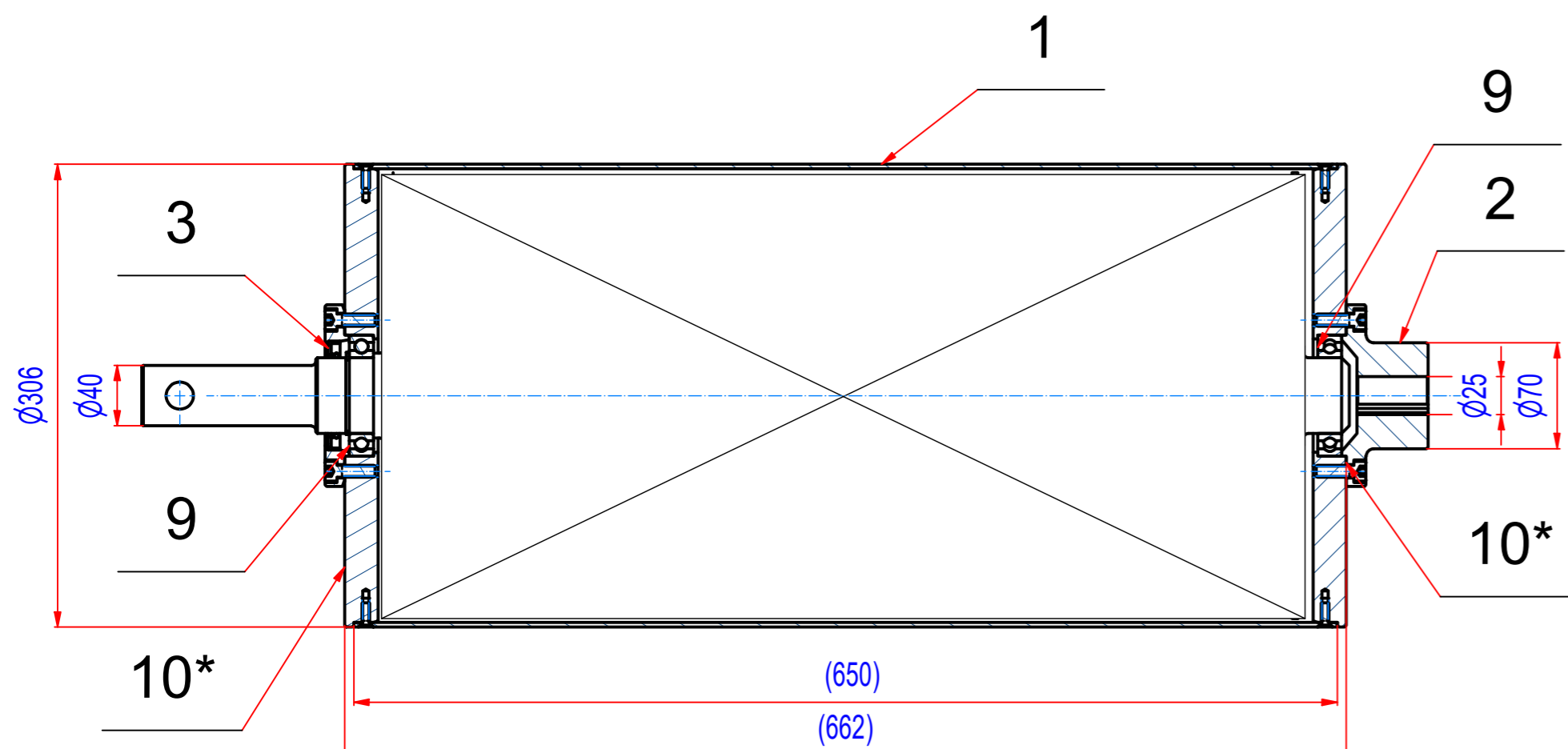
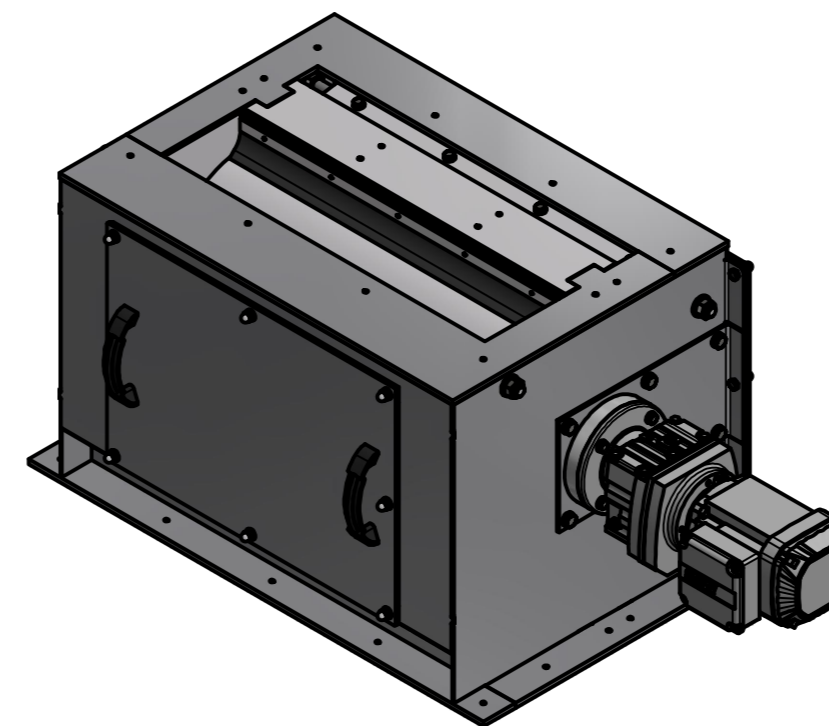

- GEARED BOX SEW RF37DRN71M4, i=55,76 (25RPM)

POZ.	Č. SOUČÁSTI	POPIS	MATERIÁL	HMOT.	MN.
14	845_060009	Top cleaning strip	FOOD PUR	0,5	1
13	A442_000009	Bottom cleaning strip	FOOD PUR	0,7	1
12	A442_000008	Input PUR slat	FOOD PUR	0,2	1
11	845_090009	Front PUR slat	FOOD PUR	0,5	1
10*	D02_020001	Al flange SRTM080034	EN AW-6082 T6	4	2
9	15_0406010	Bearing 6010-2RS1		0,2	2
8	MS03702519	SEW RF37 DRN71M4; 0,37kW; 25RPM		17	1
7	A442_000001	Input PUR slat	PUR	0,2	1
6	A442_000003	Bottom cleaning strip	PUR	0,7	1
5	A442_060001	Top cleaning strip	PUR	0,5	1
4	845_060004	Front PUR slat	PUR	0,5	1
3	74_1050082	Sealing ring NBR G 50x72x8		0	1
2	819_000003	Driving shaft	S355 (11523)	2	1
1*	845_020200_B	Shell of SRTK060034		16	1

Sheet: A2	Extra info:	General tolerance: ISO 2768 - cL
Drawn: EN	Weight (kg): 214,4	Drawn according: ISO268; ISO1101; ISO2553
Date: 27.04.2018		Status:
Predecessor:		Customer reference number:
Quick search: XSTK	© All rights reserved. Reproduction is not permitted without written permission of GOUDSMIT Magnetic Systems BV	Product key: SETK-063-SD-B-30S2-NA-FZB-B-B
Description: Spare parts for SRTK060034		Part number: SRTK060034_SP
		Rev: A