

REV	BY	DATE	DESCRIPTION
-	EN	20.02.2018	NEW VAULT, OLD REF.: SRTK060044_C
A	LF	05.05.2020	POHON IE1 NAHRAZEN POHONEM IE3

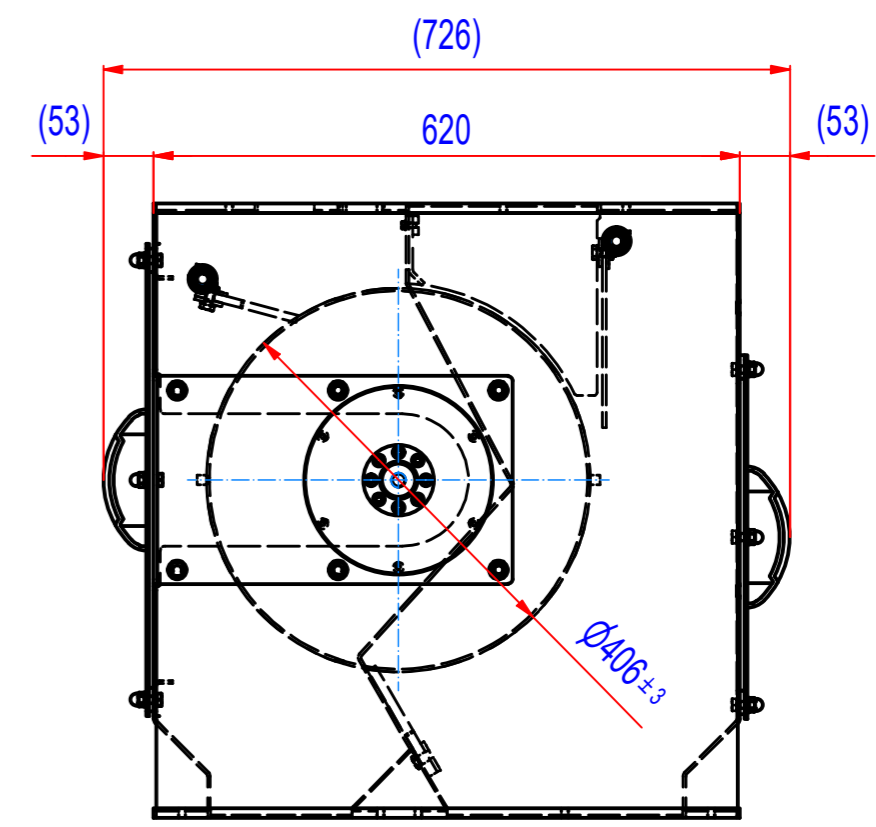

TOP FLANGE

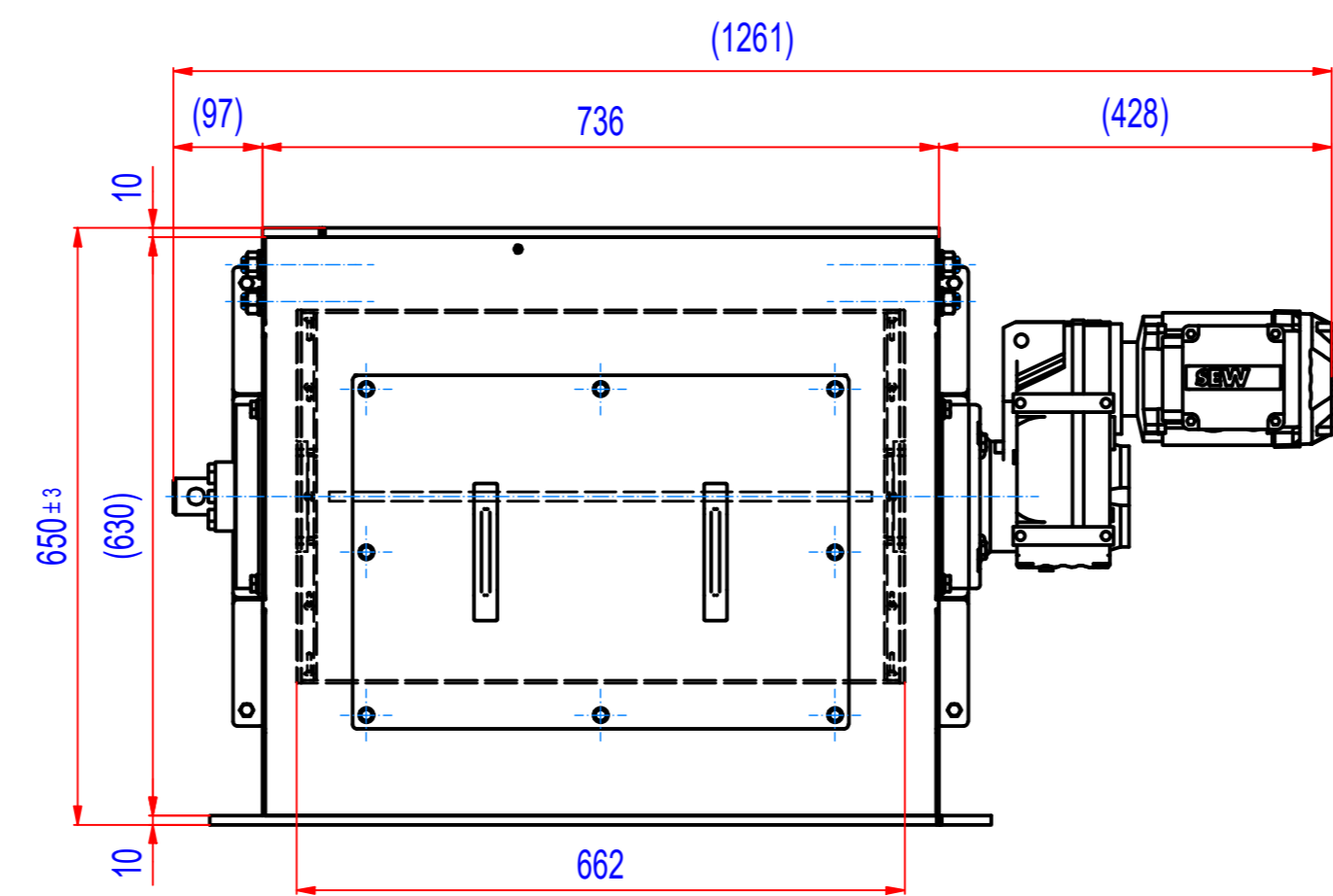
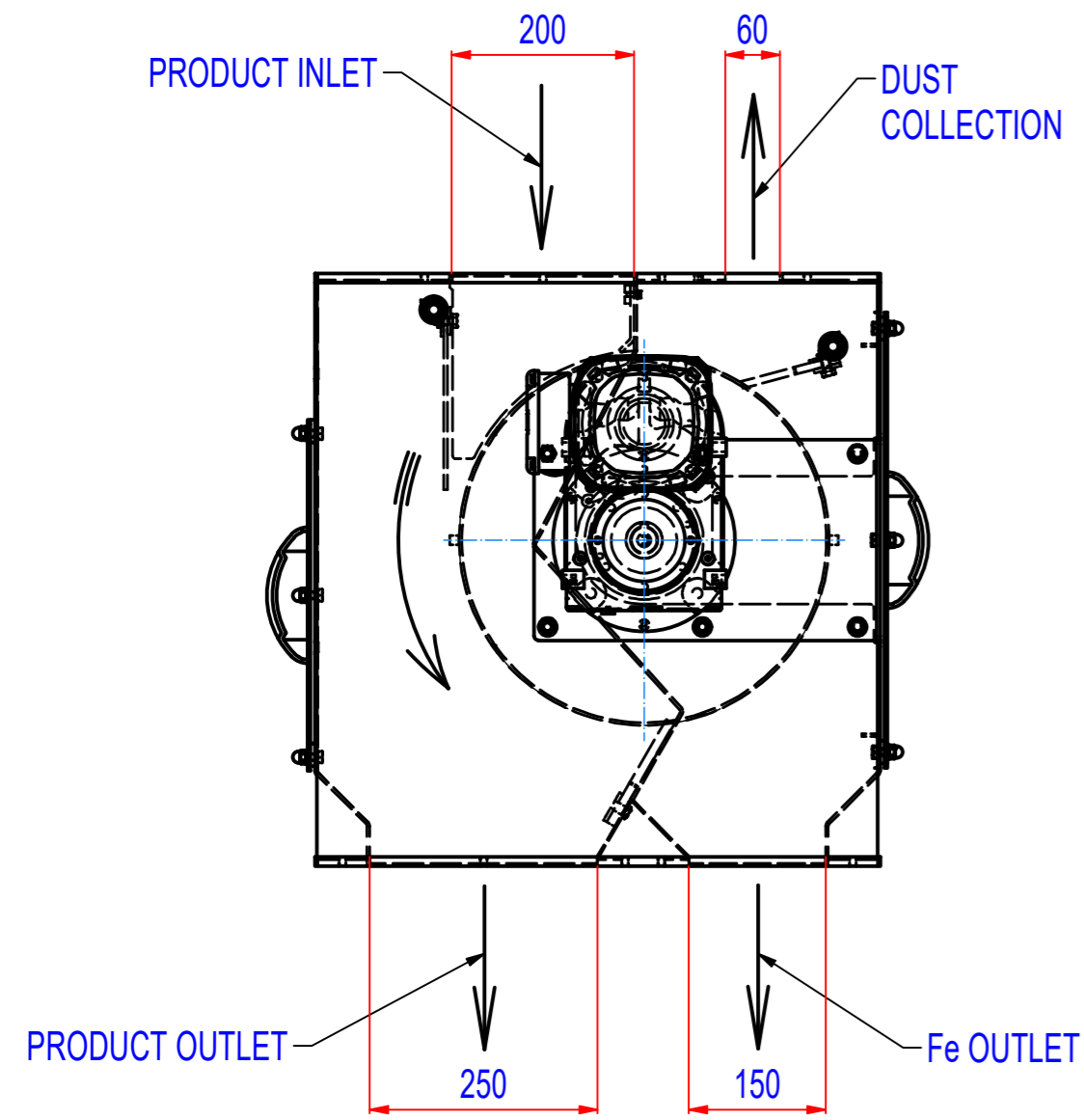
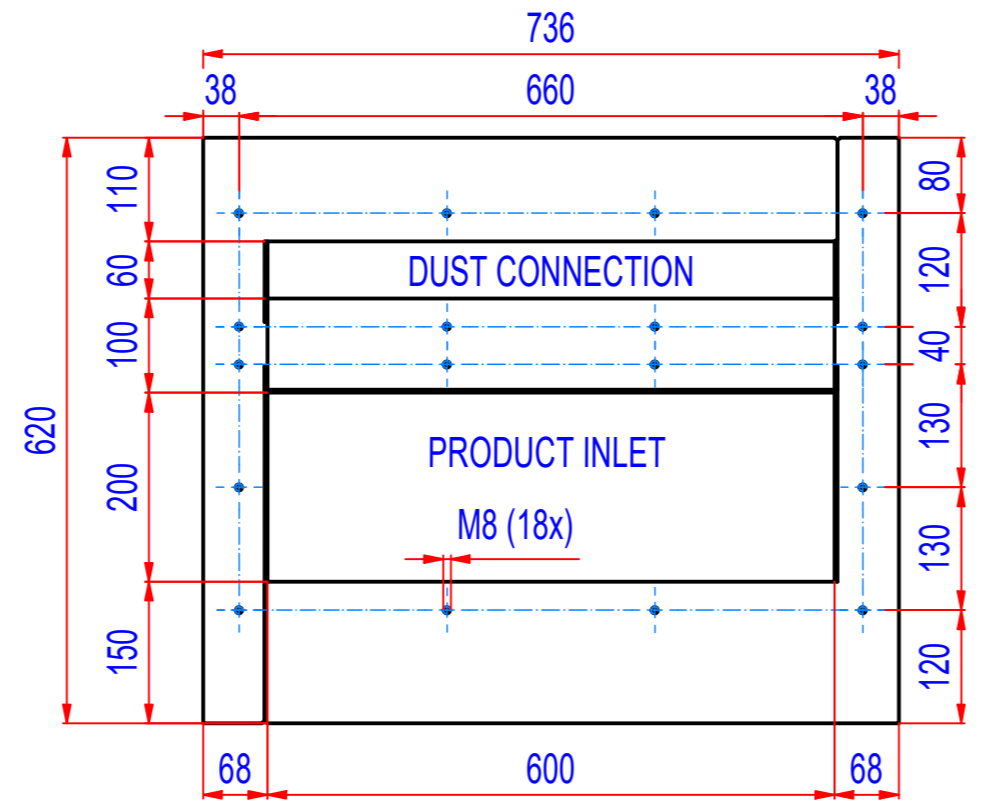

BOTTOM FLANGE

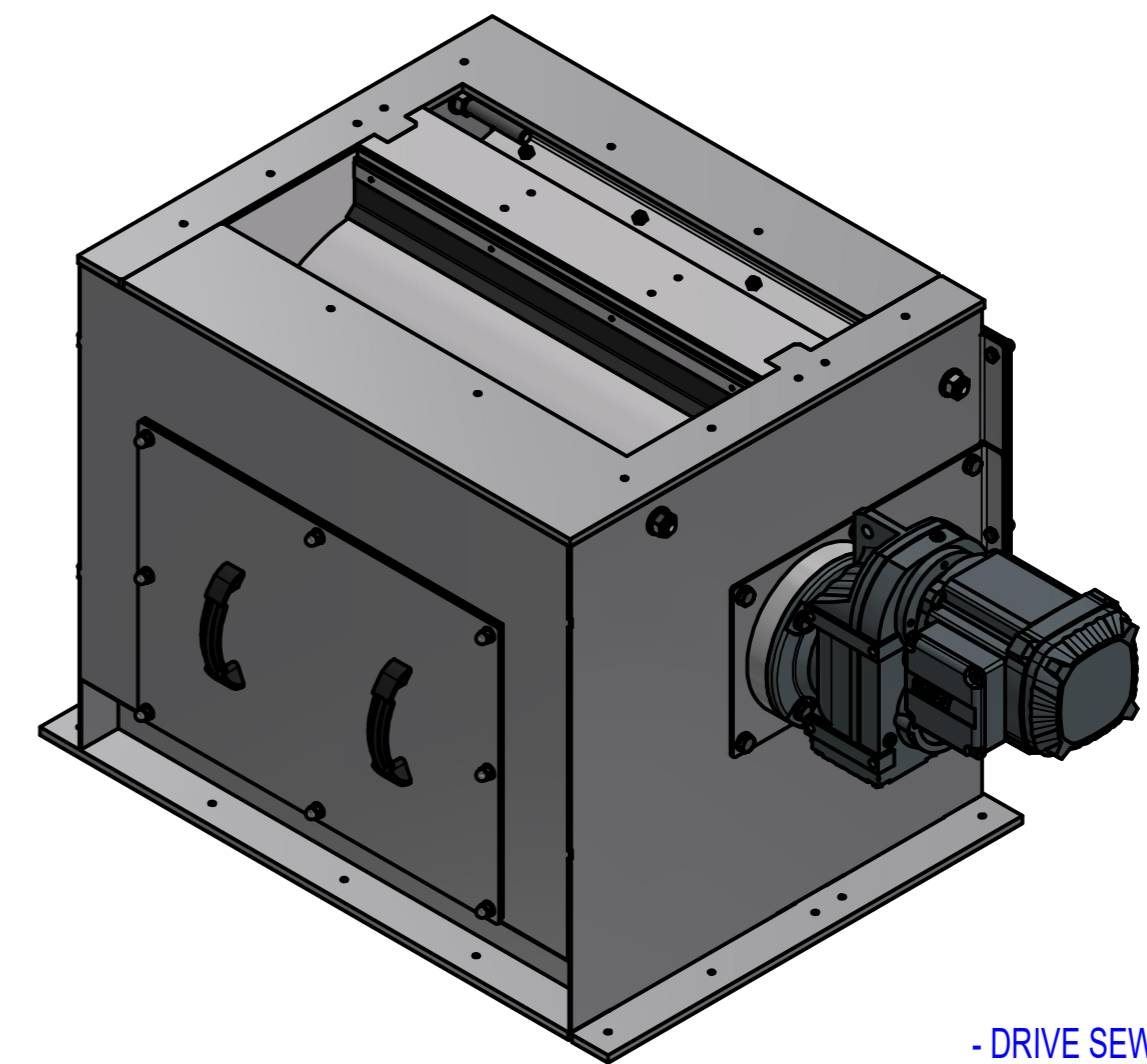
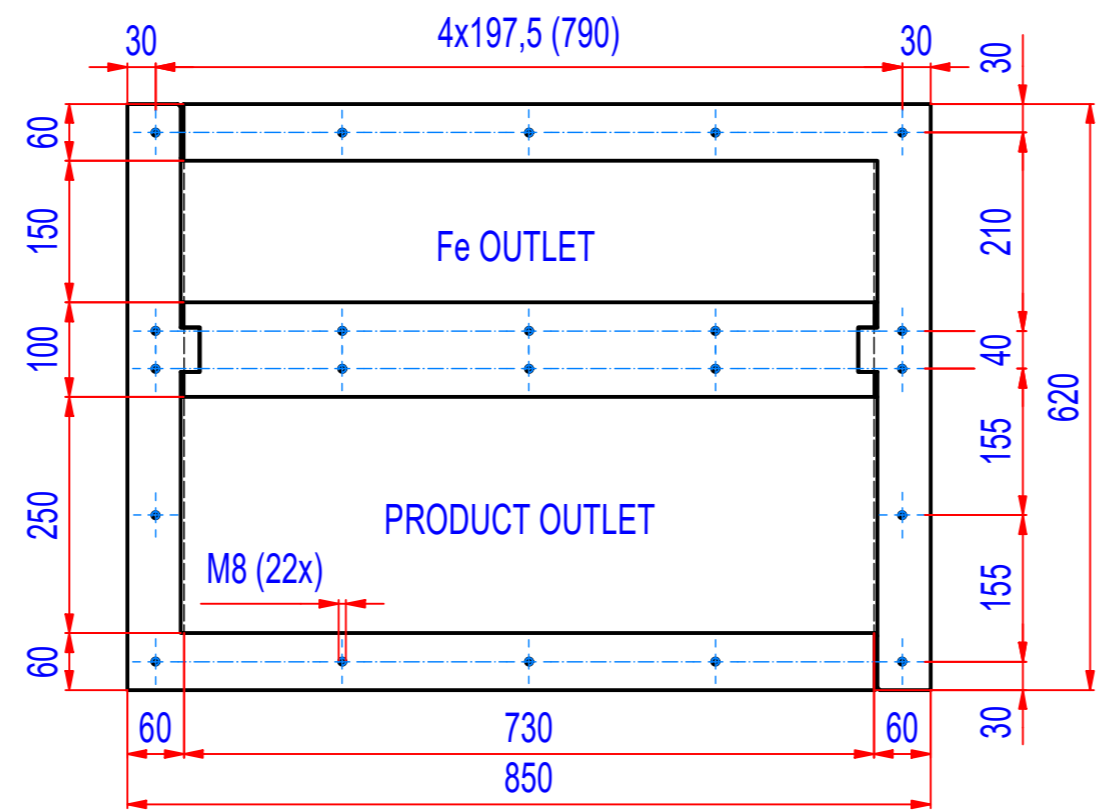

- DRIVE SEW FF47DRN80MK4, i=68,09, 21RPM,

1	A394_000000	SRTK060044		326	1
POZ.	Č. SOUČÁSTI	POPIS	MATERIÁL	HMOT.	MN.
Date:	Order ref.:	Responsible person:			
	Sheet: A2	Extra info:	General tolerance: ISO 2768 - cL		
Drawn: EN	Weight (kg): 326		Drawn according: ISO268; ISO1101; ISO2553		
Date: 10.10.2017	Predecessor:		Status:		
Quick search:	© All rights reserved. Reproduction is not permitted without written permission of GOUDSMIT Magnetic Systems BV		Customer reference number:		
Description: Drum separator in housing, Comb, D406-600	Part number: SRTK060044		Product key: SETK-064-SD-B-30S2-NA-FZB-B-B		
			Rev: -		