

REV	BY	DATE	DESCRIPTION
-	EN	11.10.2017	ORIGINAL DRAWING
A	LF	05.05.2020	MOTOR IE3 (WAS IE1)
	PH	06.11.2020	Add note + food slats

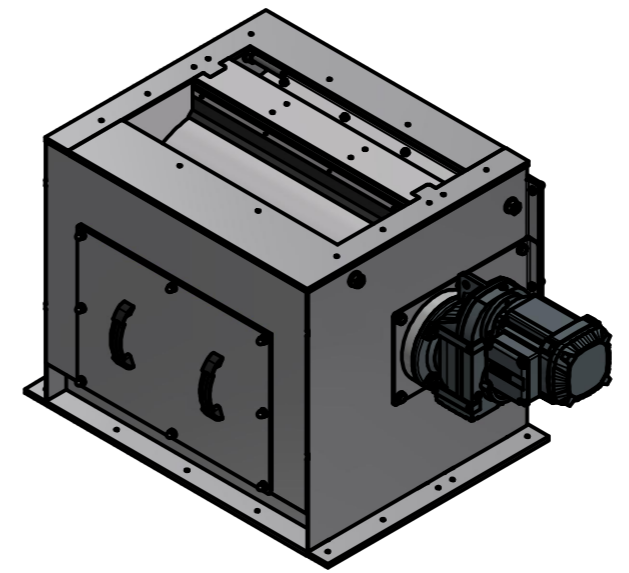

* It is recommended to replace the flanges (POS.4) and the drum shell (POS.3) at the same time.
The need to fit these parts.
Pos. 14 to 17 are intended for the food industry

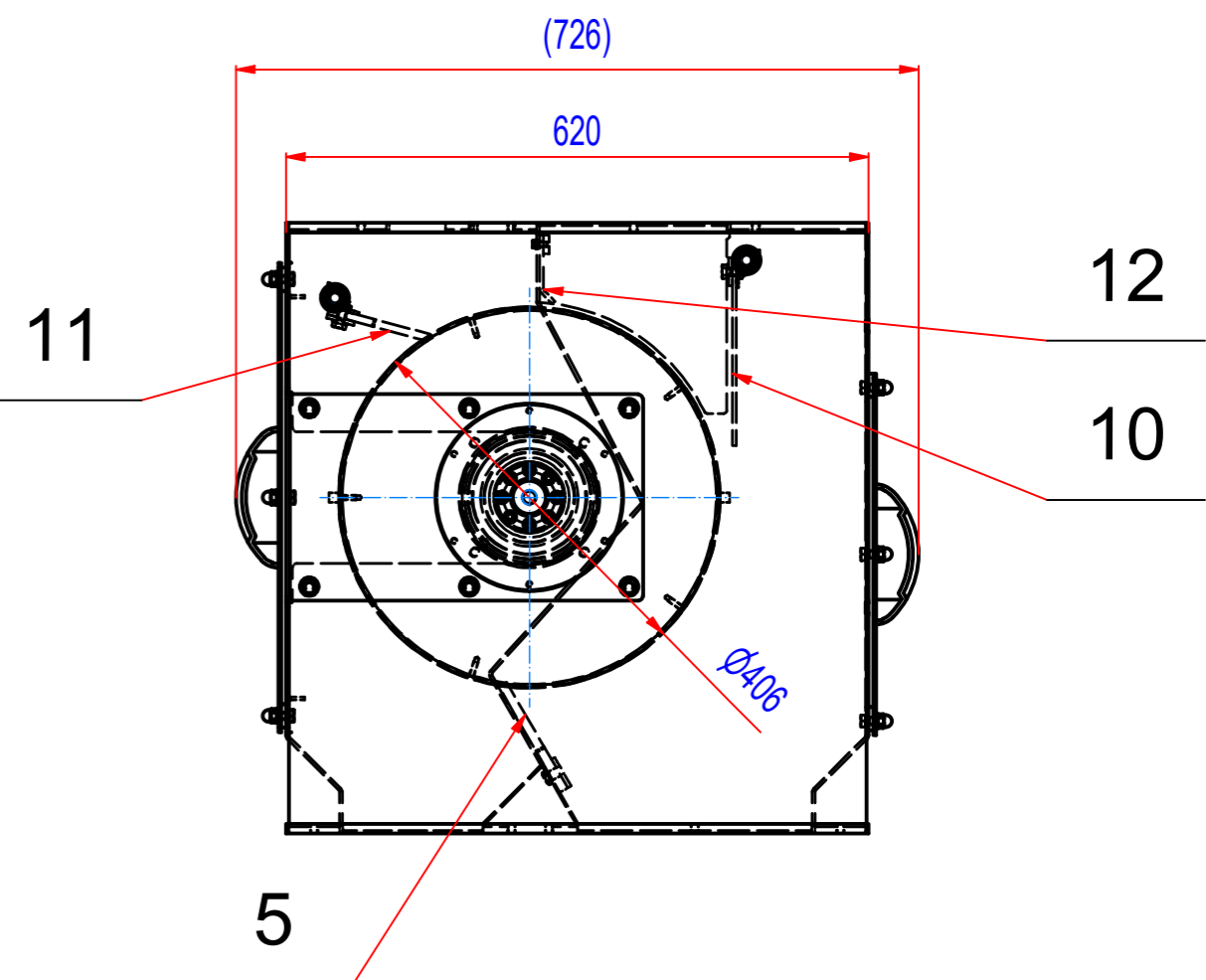
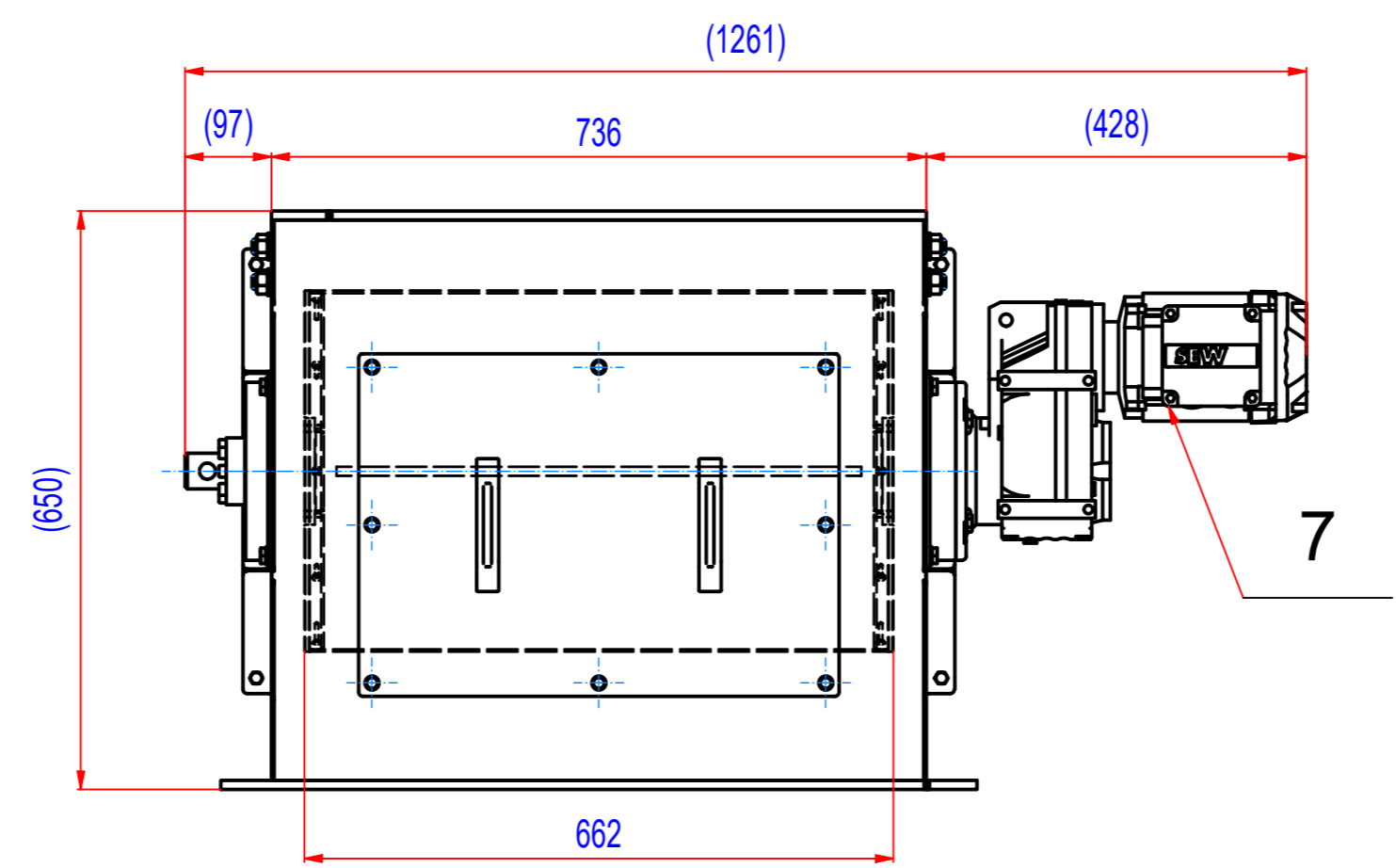
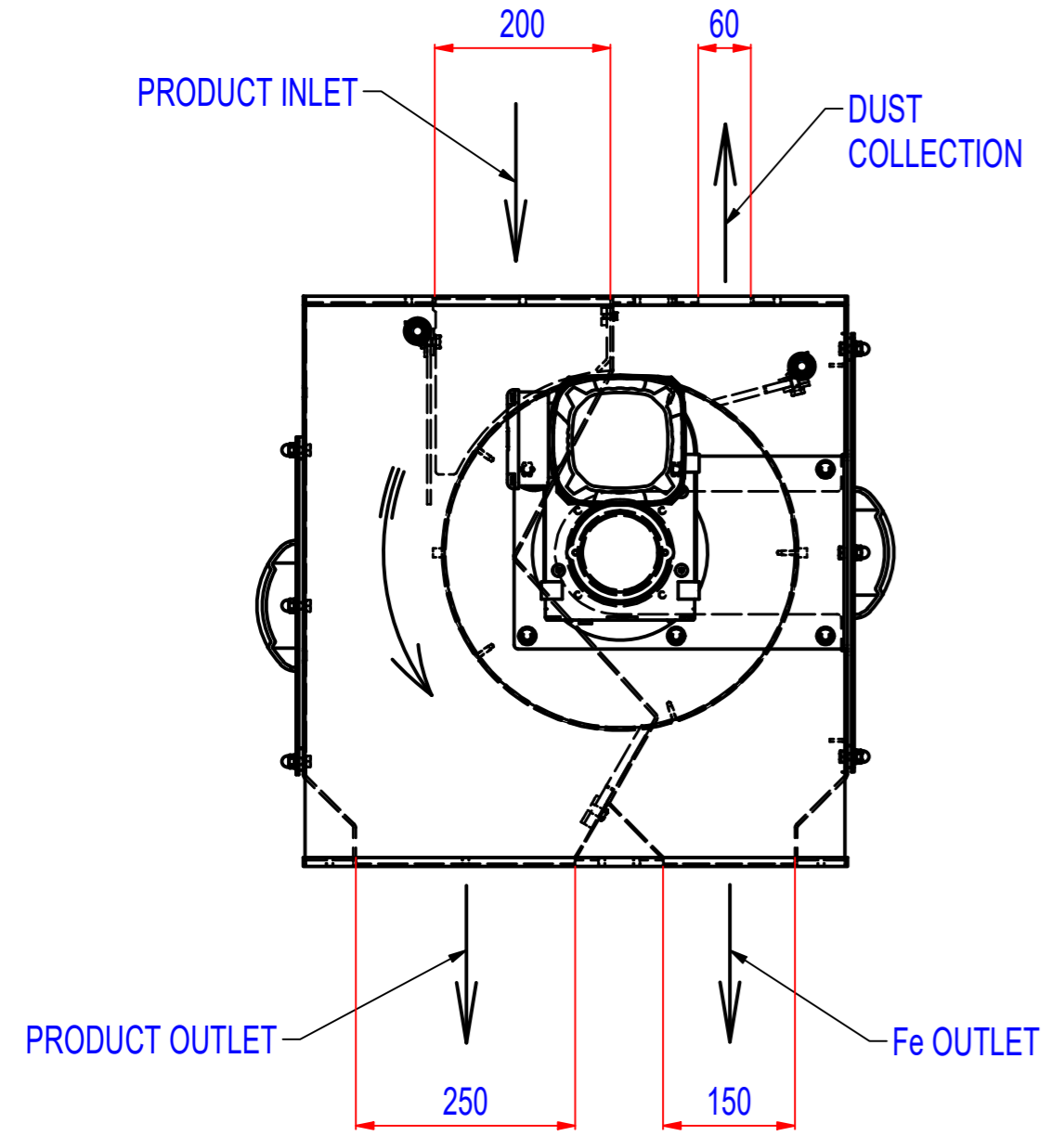
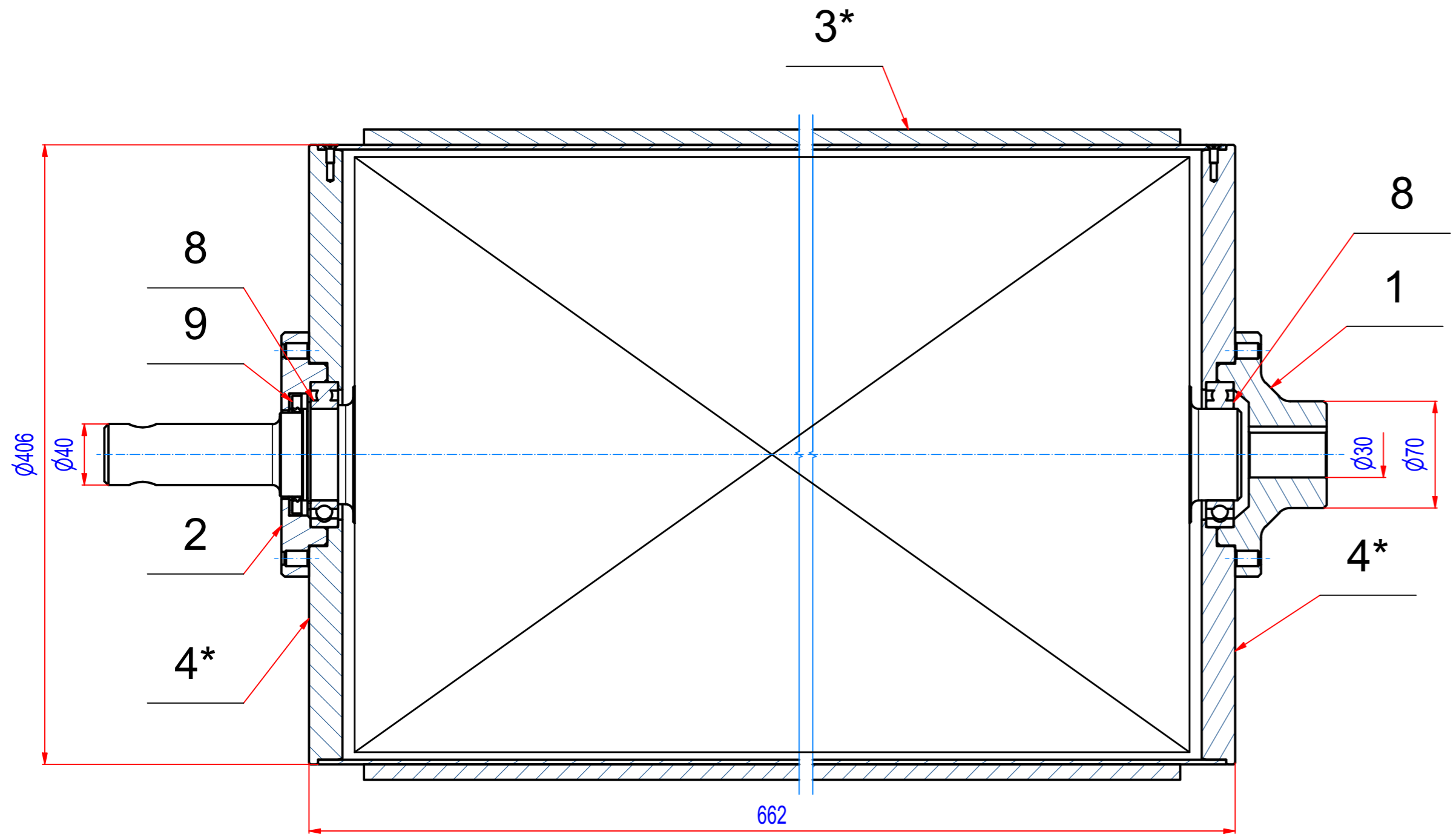

POS.	PART NR.	DESCRIPTION	MATERIAL	WEIGHT	QTY.
17	A394_00009	Inlet PUR slat	FOOD PUR	0,2	1
16	A394_05009	Top cleaning strip	FOOD PUR	0,5	1
15	A394_04009	Front PUR slat	FOOD PUR	0,5	1
14	A238_000309	Bottom cleaning strip-centre	FOOD PUR	1	1
12	A394_00001	Inlet PUR slat	PUR	0,2	1
11	A394_05002	Top cleaning strip	PUR	0,5	1
10	A394_04001	Front PUR slat	PUR	0,5	1
9	74_1055082	Sealing ring NBR G 55x80x8	RUBBER	0	1
8	15_0406012	BEARING 6012-2RS1		0,4	2
7	MH05502108	Drive SEW FF47DRN80MK4, 0,55kW, 21RPM		31	1
5	A238_000301	Bottom cleaning strip-centre	PUR	0,8	1
4*	A022_010002	Al front drum SRTK011660	EN AW-6082 T6	7	2
3*	A394_010300	Shell of SRTK060044	AISI 304	27,2	1
2	A022_010004	Front cap SRTK011660	S355 (11523)	2,5	1
1	A022_010003	Driving shaft	S355 (11523)	3,9	1

Sheet: A2	Extra info:	General tolerance: ISO 2768 - cL
Drawn: EN	Weight (kg): 326	Drawn according: ISO268; ISO1101; ISO2553
Date: 11.10.2017		Status:
Predecessor:		Customer reference number:
Quick search:	© All rights reserved. Reproduction is not permitted without written permission of GOUDSMIT Magnetic Systems BV	Product key: SETK-064-SD-B-30S2-NA-FZB-B-B
Description: SPARE PARTS FOR SRTK060044	Part number: SRTK060044	Rev: A