

REV	BY	DATE	DESCRIPTION
-	LF	11.10.2017	ORIGINAL DRAWING
A	LF	13.05.2020	MOTOR IE3 (WAS IE1)
	PH	09.11.2020	Add note + food slats

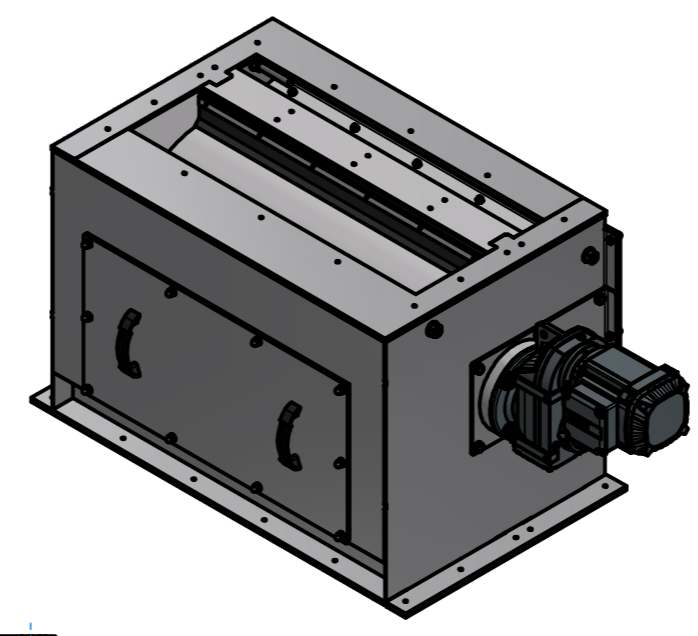

* It is recommended to replace the flanges (POS.4) and the drum shell (POS.3) at the same time.
The need to fit these parts.
Pos. 14 to 18 are intended for the food industry

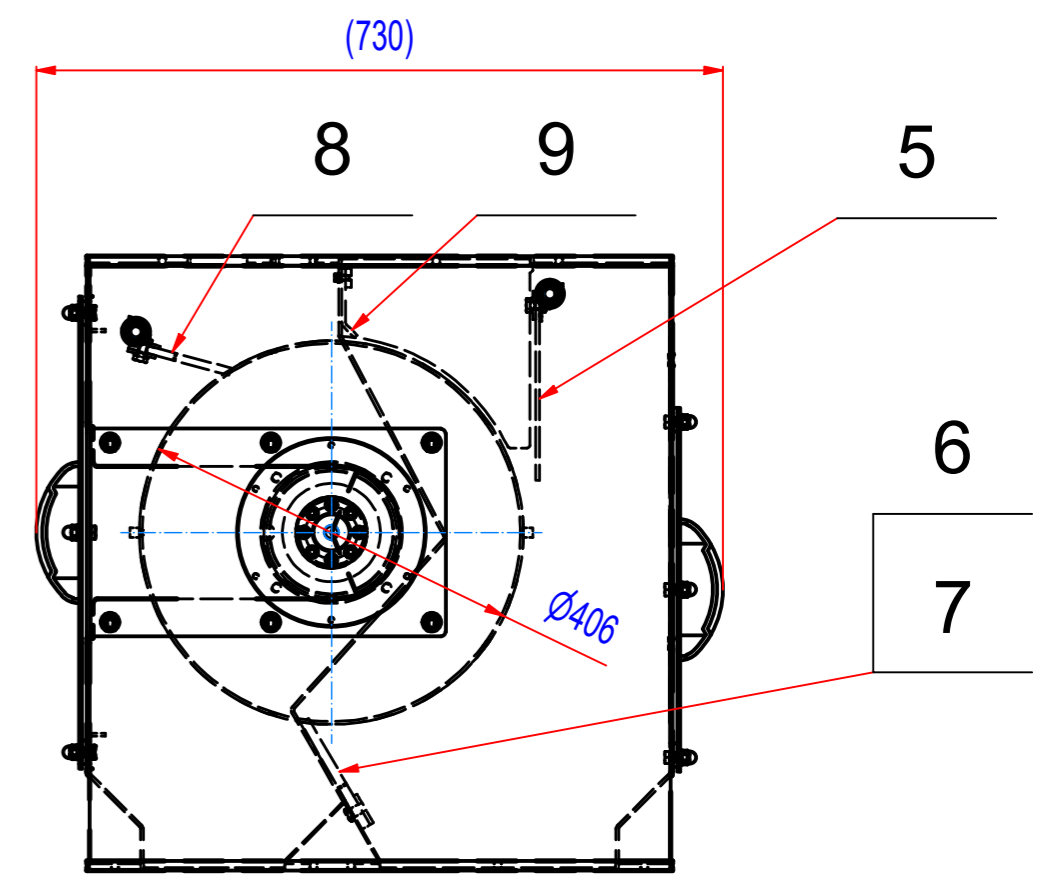
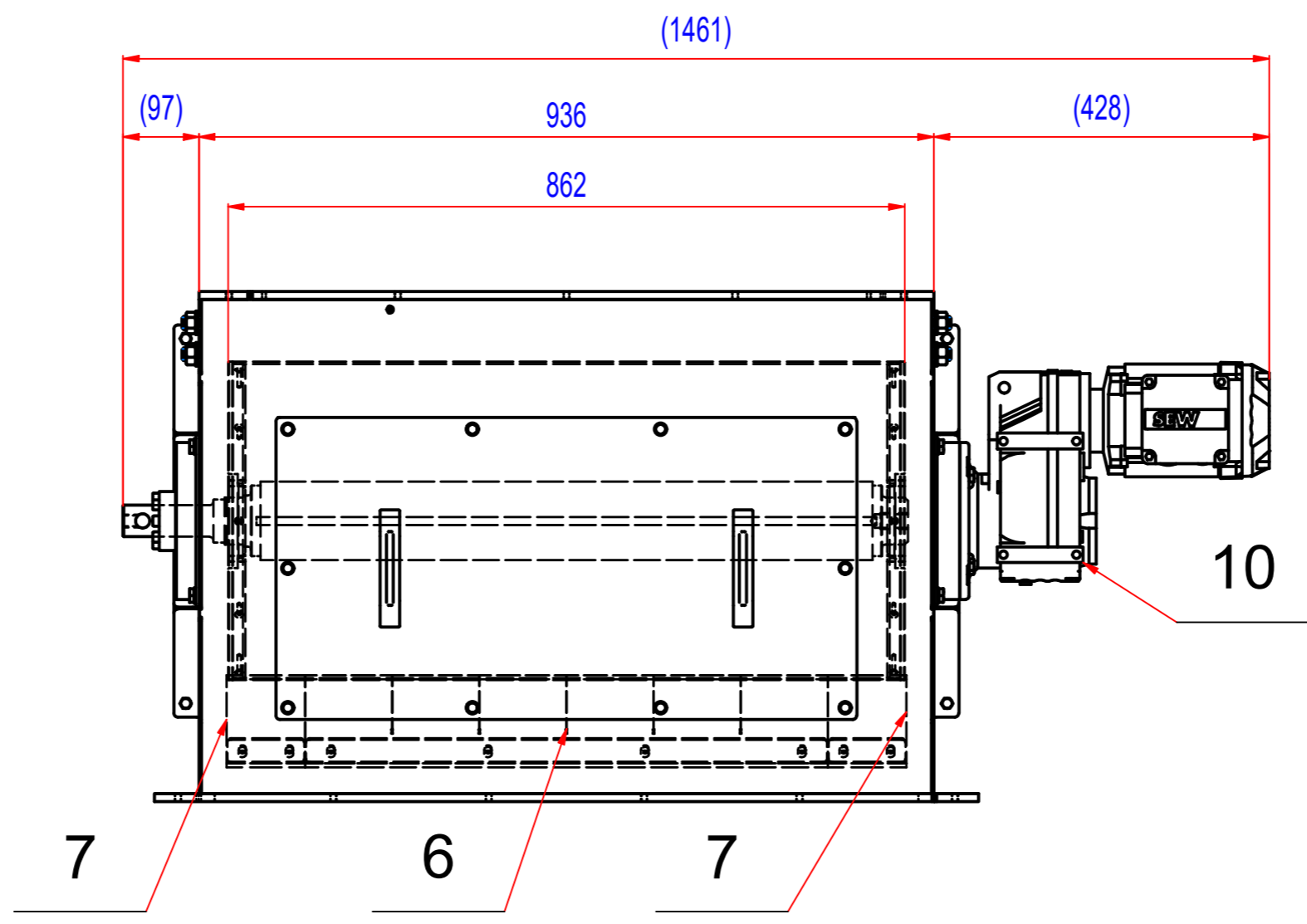
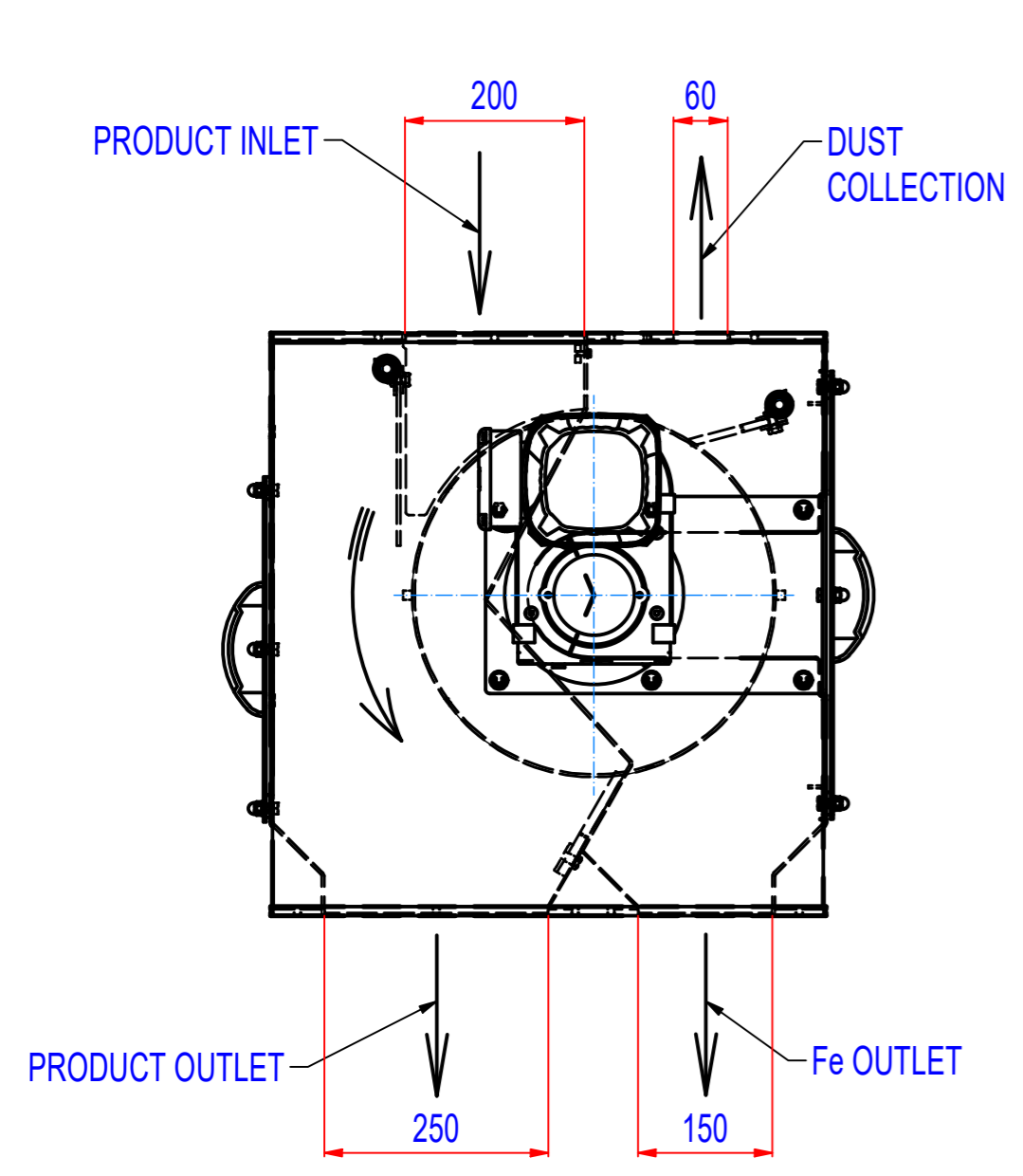
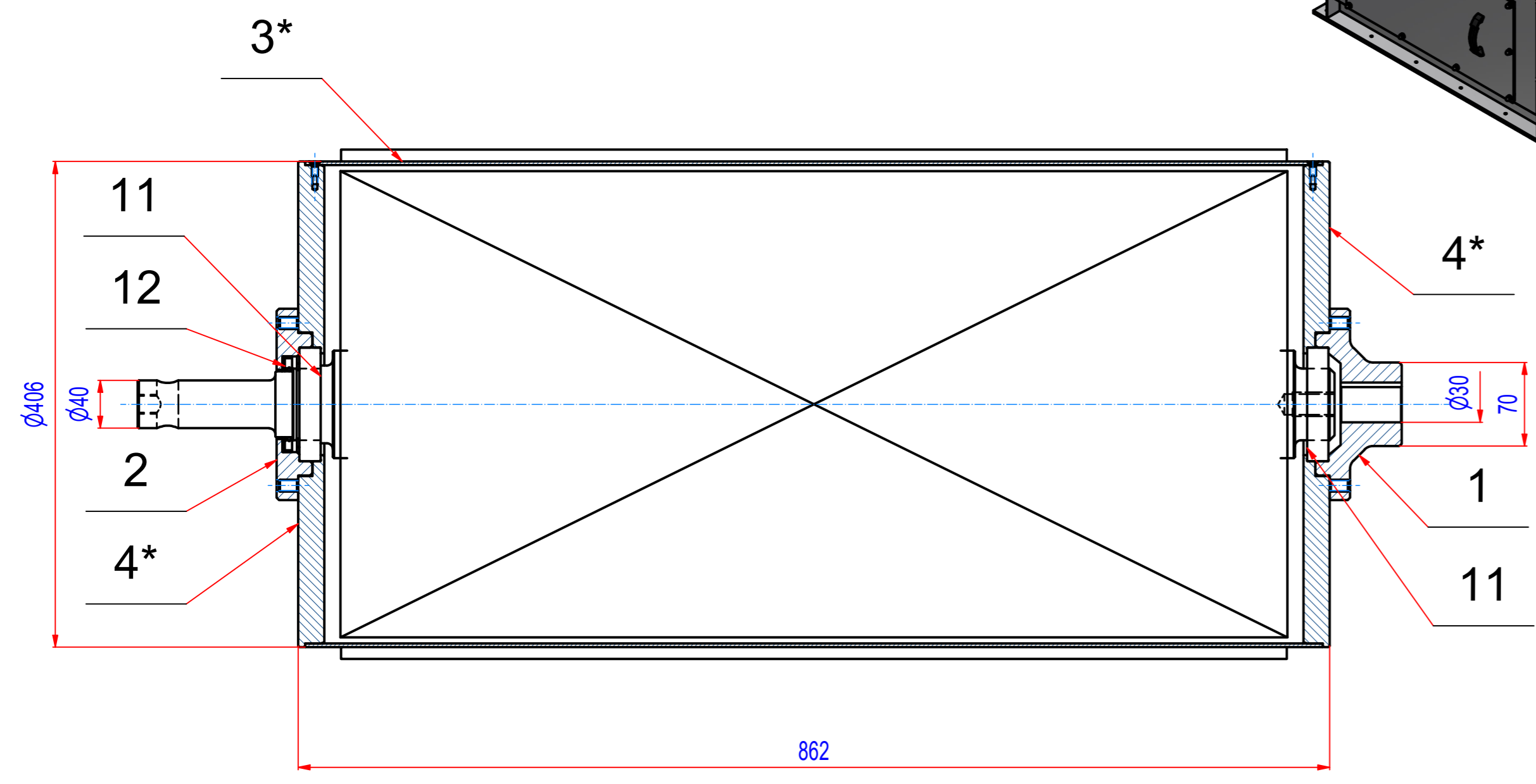

POZ.	Č. SOUČÁSTI	POPIS	MATERIÁL	HMOT.	MN.
18	A281_00009	Inlet PUR slat	FOOD PUR	0,2	1
17	A281_050009	Top cleaning strip	FOOD PUR	0,7	1
16	A281_040009	Front PUR slat	FOOD PUR	0,6	1
15	A238_000308	Bottom cleaning strip-100mm	FOOD PUR	0,1	2
14	A238_000309	Bottom cleaning strip-centre	FOOD PUR	0,8	1
12	74_1055082	Sealing ring NBR G 55x80x8	RUBBER	0	1
11	15_0406012	Bearing 6012-2RS1		0,4	2
10	MH05502108	Drive SEW FF47DRN80MK4, 0,55kW, 21RPM		31	1
9	A281_000001	Inlet PUR slat	PUR	0,2	1
8	A281_050002	Top cleaning strip	PUR	0,7	1
7	A238_000302	Bottom cleaning strip-100mm	PUR	0,1	2
6	A238_000301	Bottom cleaning strip-centre	PUR	0,8	1
5	A281_040001	Front PUR slat	PUR	0,6	1
4	A022_010002	Al front drum SRTK011660	EN AW-6082 T6	7	2
3	C87_020000_B	Shell of SRTK080044	AISI 304	27,2	1
2	A022_010004	Front cap SRTK011660	S355 (11523)	2,5	1
1	A022_010003	Driving shaft SRTK011660	S355 (11523)	3,9	1

Sheet: A2	Extra info:	General tolerance: ISO 2768 - cL
Drawn: LF	Weight (kg): 398,2	Drawn according: ISO268; ISO1101; ISO2553
Date: 11.10.2017		Status:
Predecessor:		Customer reference number:
Quick search:	© All rights reserved. Reproduction is not permitted without written permission of GOUDSMIT Magnetic Systems BV	Product key: SETK-084-SD-B-30S2-NA-FZB-B-B
Description: SPARE PARTS FOR SRTK080044	Part number: SRTK080044_SP	Rev: A