

REV	BY	DATE	DESCRIPTION
-	PH	24.08.2017	New Vault, REF: 822_000000_C
A	LF	13.05.2020	MOTOR IE3 (WAS IE1)

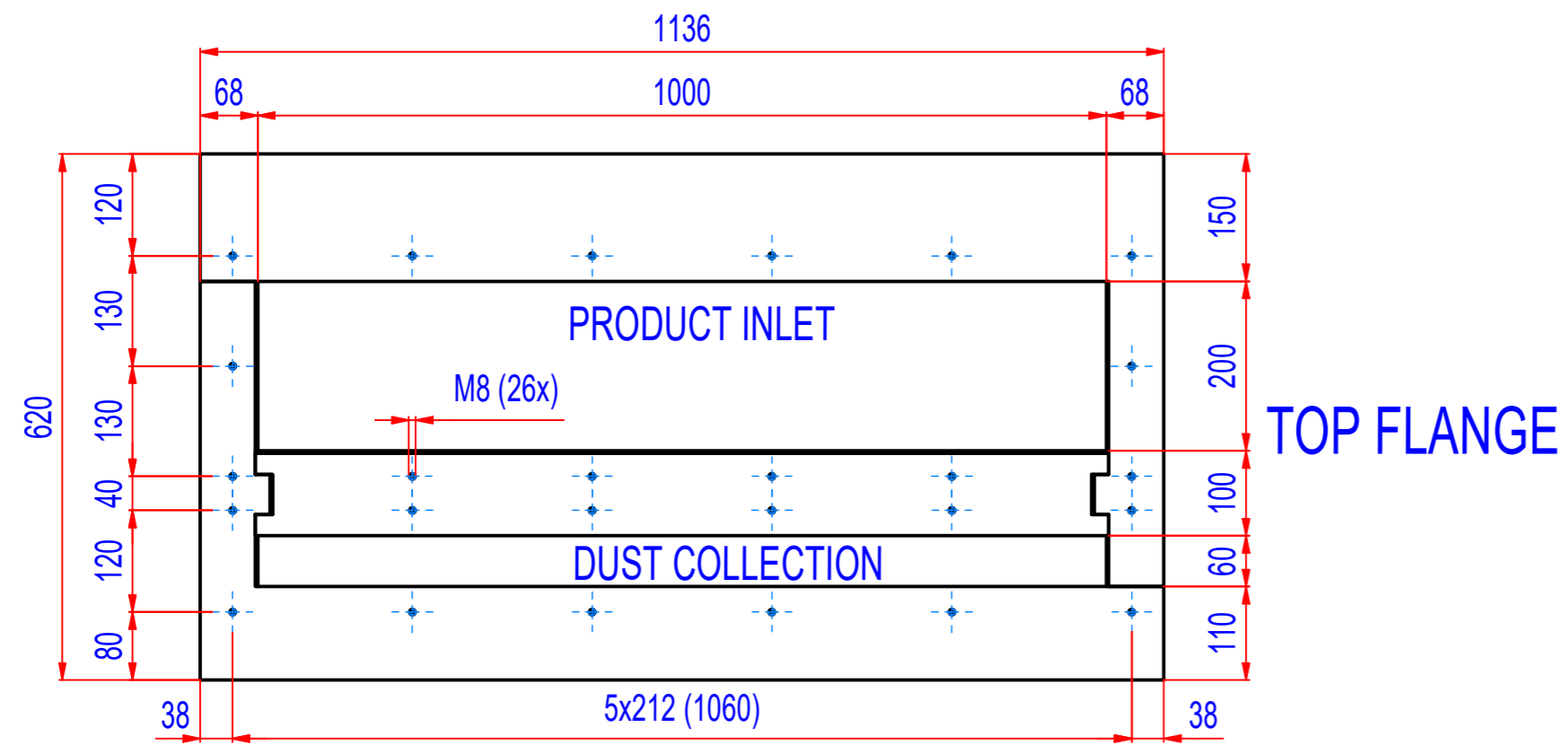

- DRIVE SEW FF47DRN80MK4, i=68,09 (21RPM),

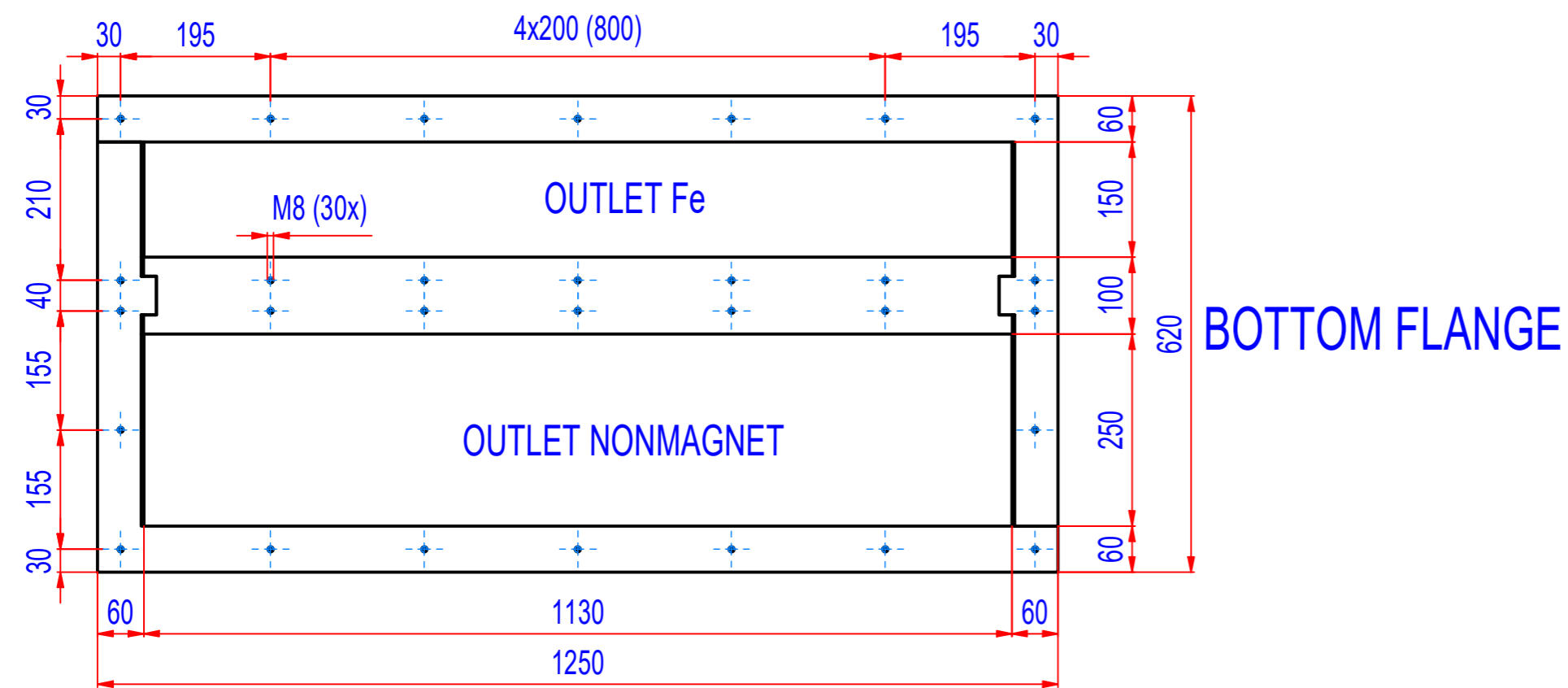
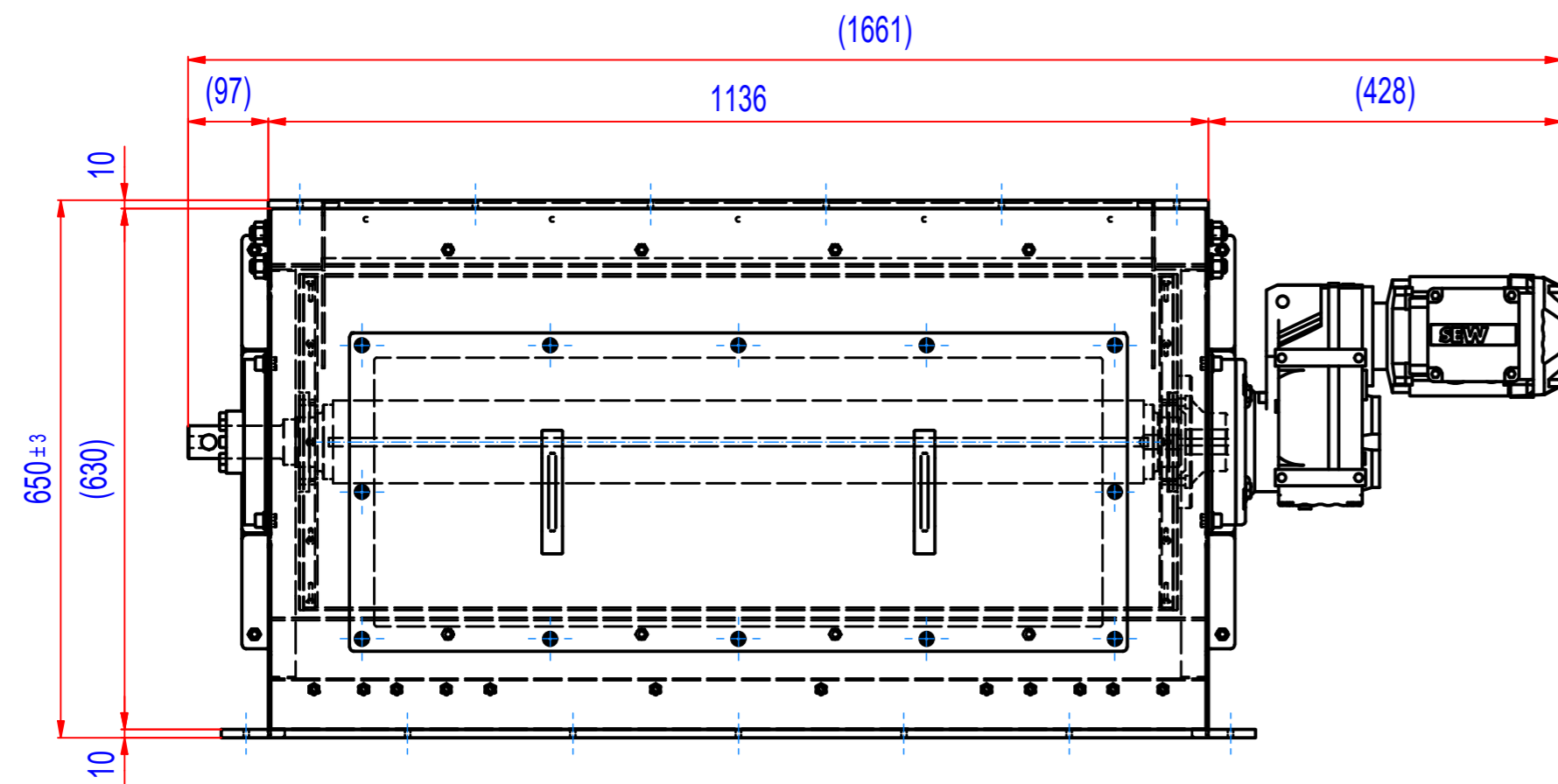
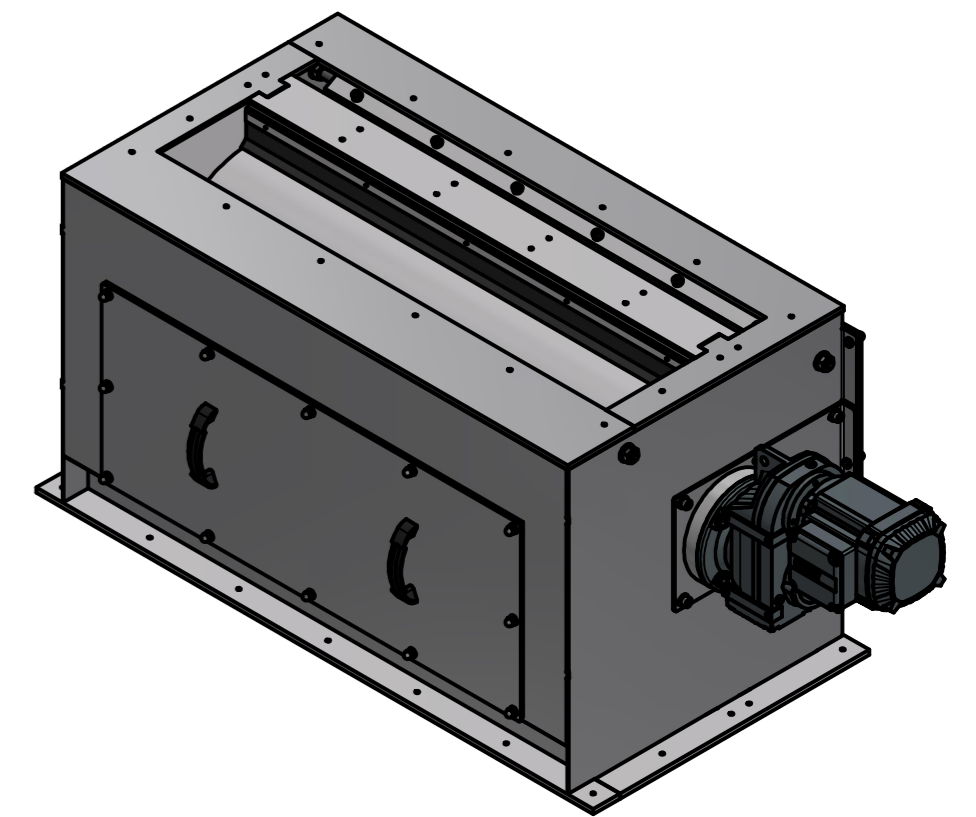
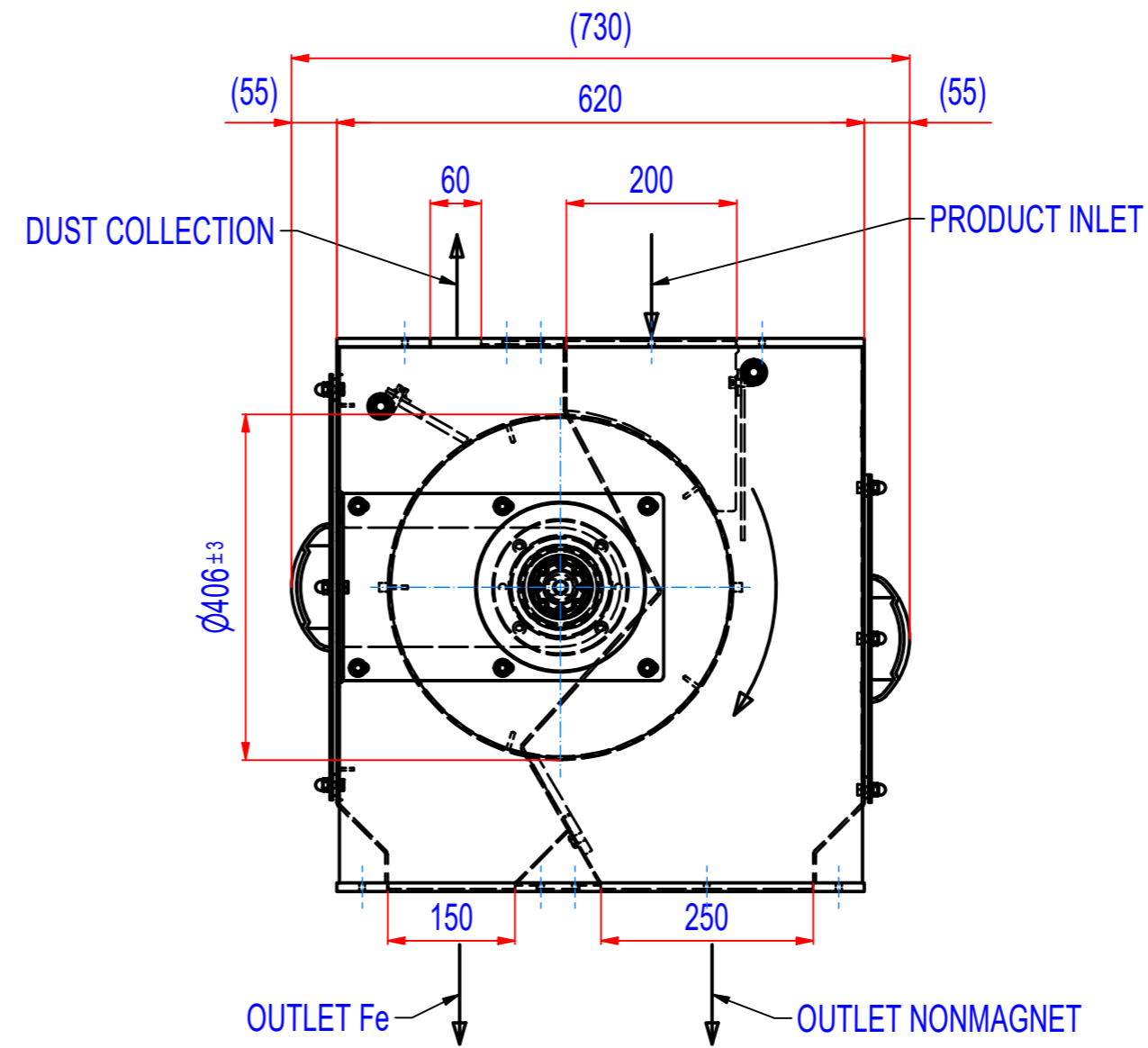

1	A238_000000	Bubnový separátor ve skříni, Comb, D406-1000	472
POZ./POS.	Č. SOUČÁSTI/ PART NUMBER	POPIS / DESCRIPTION	HMOT./ WEIGHT
Date:	Order ref.:	Responsible person:	
Drawn: PH	Weight (kg): 472	Extra info:	General tolerance: ISO 2768 - cL
Date: 23.01.2017	Predecessor: 822_000000	<p>© All rights reserved. Reproduction is not permitted without written permission of GOUDSMIT Magnetic Systems BV</p>	Drawn according: ISO268; ISO1101; ISO2553
Quick search: XSTK 400	Description: Drum separator in housing, Comb, D406-1000		Status:
		Product key: SETK-104-SD-B-30S2-NA-FZB-B-B	Part number: SRTK100044
			Rev: A