

REV	BY	DATE	DESCRIPTION
-	PH	24.08.2017	New Vault, REF: 822_000000_C
A	LF	13.05.2020	MOTOR IE3 (WAS IE1)
	PH	06.11.2020	Add note + food slats

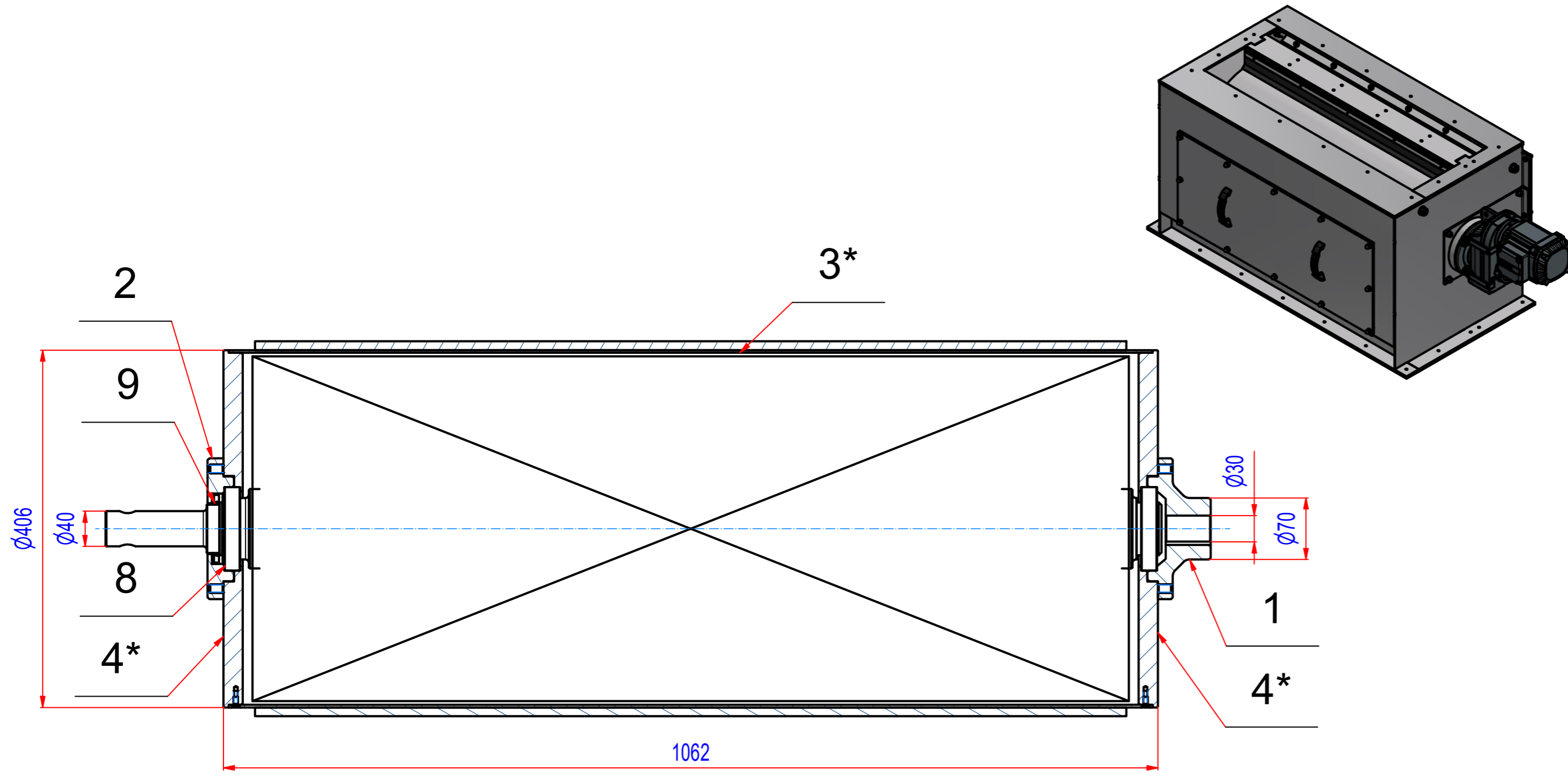
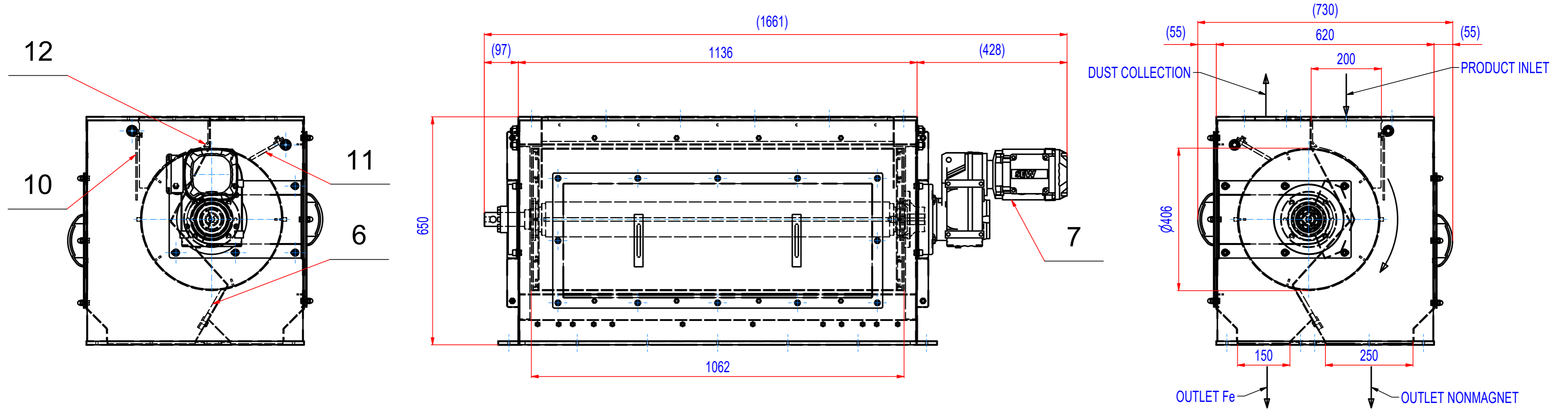

\* It is recommended to replace the flanges (POS.4) and the drum shell (POS.3) at the same time.  
The need to fit these parts.  
Pos. 14 to 18 are intended for the food industry

POZ.	Č. SOUČÁSTI	POPIS	MATERIÁL	HMOT.	MN.
18	A238_000009	Inlet PUR slat	FOOD PUR	0,3	1
17	A238_000209	Top cleaning strip	FOOD PUR	0,8	1
16	A238_000109	Front PUR slat	FOOD PUR	0,8	1
15	A238_000308	Bottom cleaning strip-100mm	FOOD PUR	0,1	4
14	A238_000309	Bottom cleaning strip-centre	FOOD PUR	0,8	1
12	A238_000004	Inlet PUR slat	PUR	0,3	1
11	A238_000201	Top cleaning strip	PUR	0,8	1
10	A238_000103	Front PUR slat	PUR	0,8	1
9	74_1055082	Sealing ring NBR G 55x80x8		0	1
8	15_0406012	Bearing 6012-2RS1		0,4	2
7	MH05502108	Drive SEW FF47DRN80MK4, 0,55kW, 21RPM		31	1
6	A238_000302	Bottom cleaning strip-100mm	PUR	0,1	4
5	A238_000301	Bottom cleaning strip-centre	PUR	0,8	1
4*	A022_010002	Al front drum SRTK011660	EN AW-6082 T6	7	2
3*	A022_010200	Shell of SRTK100044	AISI304	32	1
2	A022_010004	Front cap SRTK011660	S355 (11523)	2,5	1
1	A022_010003	Driving shaft SRTK011660	S355 (11523)	3,9	1

**NOTES**  
- DRIVE SEW FF47DRN80MK4, i=68,09 (21RPM),

Sheet: A2	Extra info:	General tolerance: ISO 2768 - cL
Drawn: PH	Weight (kg): 472	Drawn according: ISO268; ISO1101; ISO2553
Date: 23.01.2017		Status:
Predecessor: 822_000000		Customer reference number:
Quick search: XSTK 400	© All rights reserved. Reproduction is not permitted without written permission of GOUDSMIT Magnetic Systems BV	Product key: SETK-104-SD-B-30S2-NA-FZB-B-B
Description: SPARE PARTS for drum separator in housing, Comb, D406-1000		Part number: SRTK100044_SP Rev: A