

REV	BY	DATE	DESCRIPTION
-	PH	01.09.2016	New Vault, old rev.E, PUR slat
A	JIK	01.11.2023	DRIVE WAS CHANGED FROM MH07502104 IP54 TO MH07502110 IP55, PRODUCT KEY CORRECTED, HOLES OF TOP AND BOTTOM FLANGES CHANGED

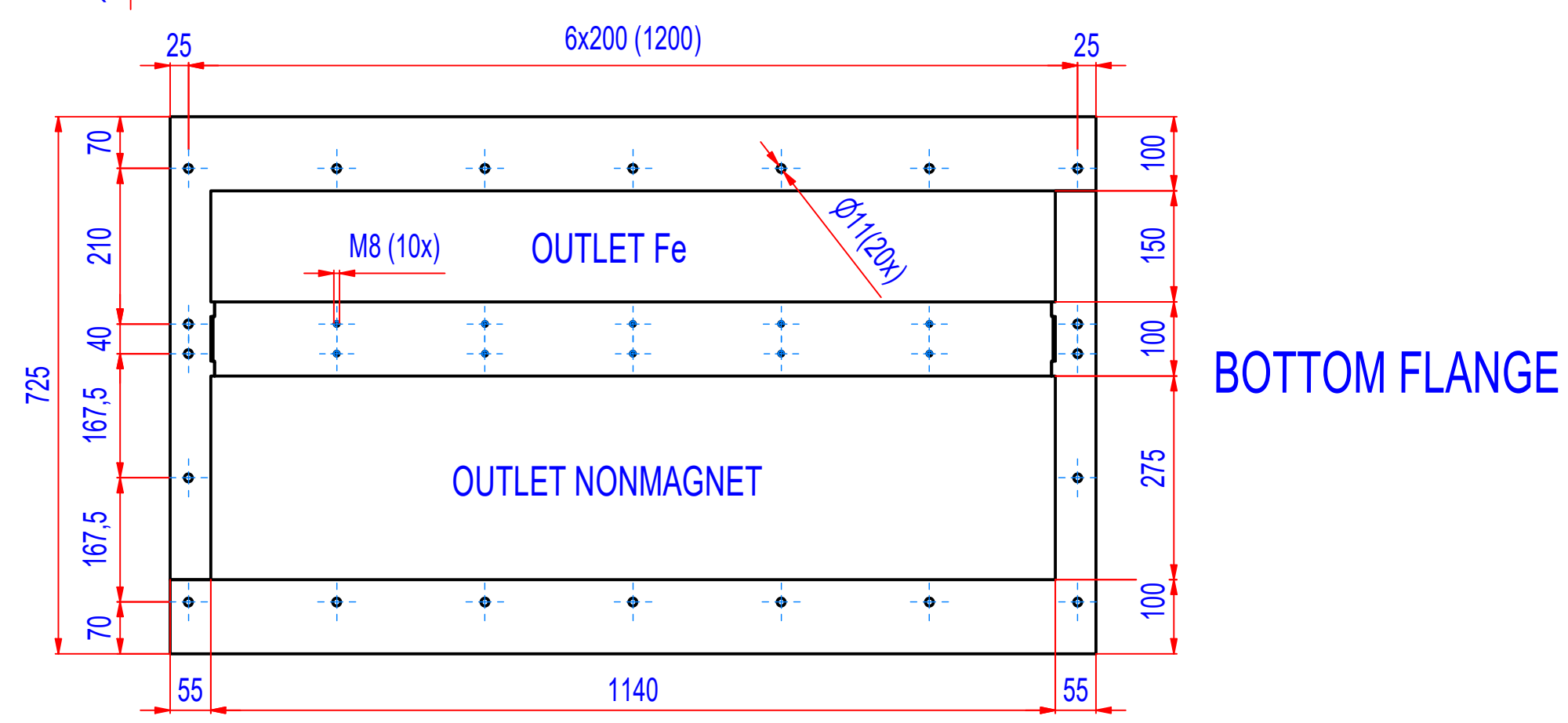
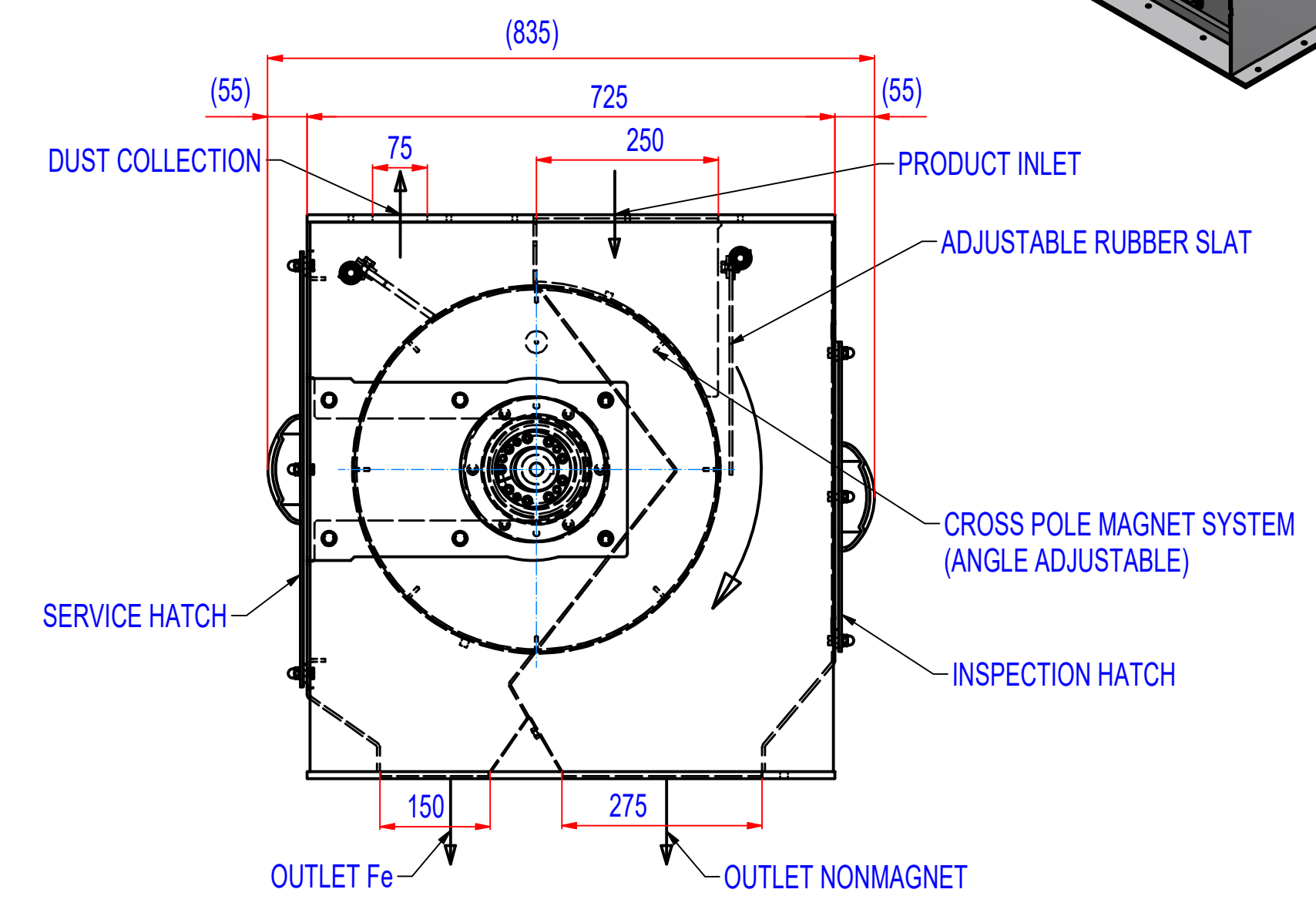
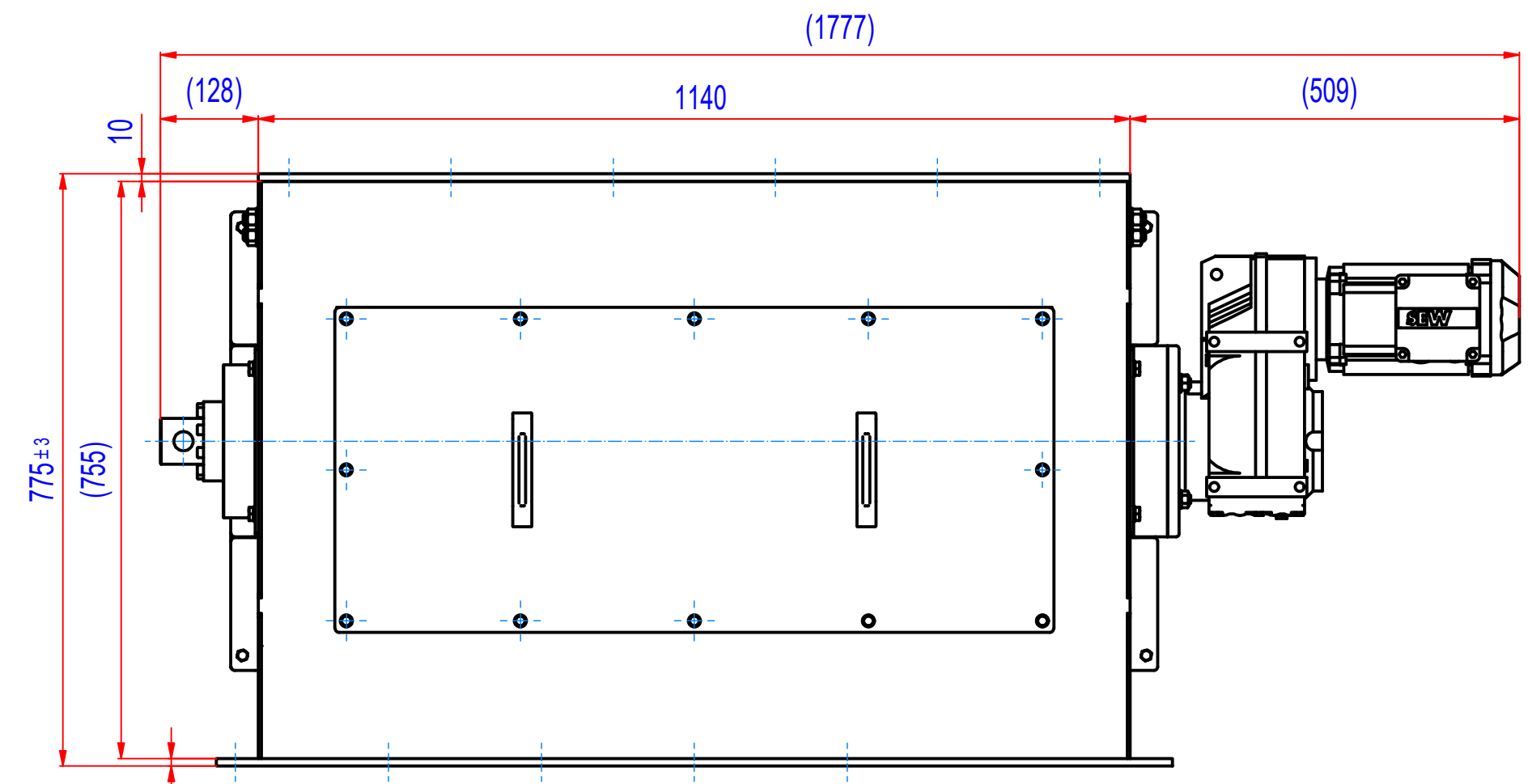
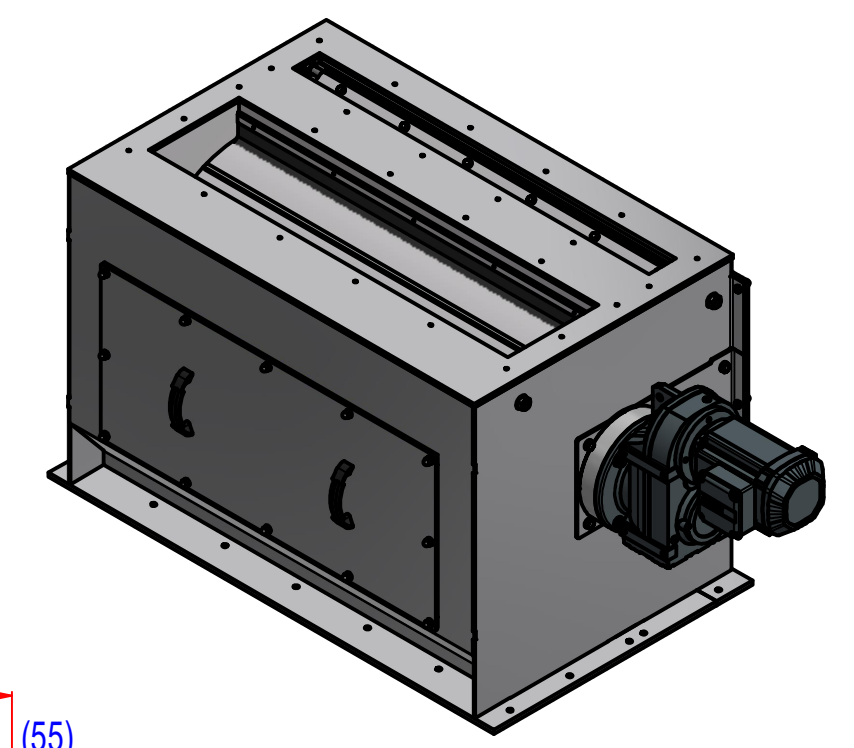
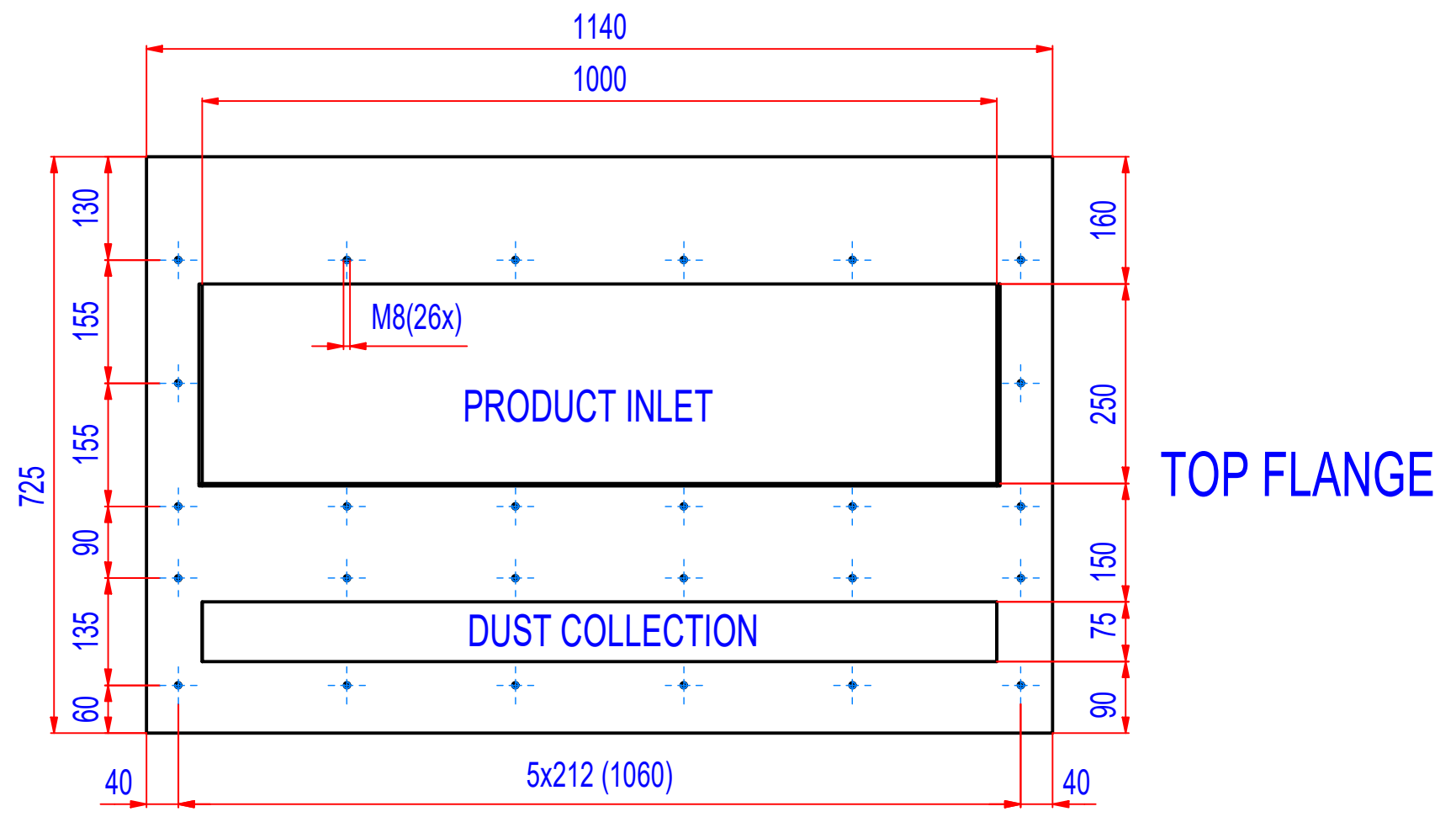

NOTES

-DRIVE SEW FF67DRN80M4, 0,75kW, i=67,65, 20 RPM

1	A243_000000	SRTK100054	702,2
POZ./POS.	Č. SOUČÁSTI/ PART NUMBER	POPIS / DESCRIPTION	HMOT./ WEIGHT
Date:	Order ref.:	Responsible person:	
Sheet: A2	Extra info:	General tolerance: ISO 2768 - cL	
Drawn: PH	Weight (kg): 702.2	Drawn according: ISO268; ISO1101; ISO2553	
Date: 01.11.2023	Predecessor: 991_000000	Status:	
Quick search:	<p>© All rights reserved. Reproduction is not permitted without written permission of GOUDSMIT Magnetic Systems BV</p>	Customer reference number:	
Description: Drum separator in housing, Comb, D506-1000		Product key: SETK-105-SD-B-30S2-NA-FZB-B-B	Part number: SRTK100054