

REV	BY	DATE	DESCRIPTION
-	PH	01.09.2016	New Vault, old rev.E, PUR slat
	PH	11.11.2020	Add note + food slats
A	JIK	01.11.2023	DRIVE WAS CHANGED FROM MH07502104 IP54 TO MH07502110 IP55, PRODUCT KEY CORRECTED, HOLES OF TOP AND BOTTOM FLANGES CHANGED

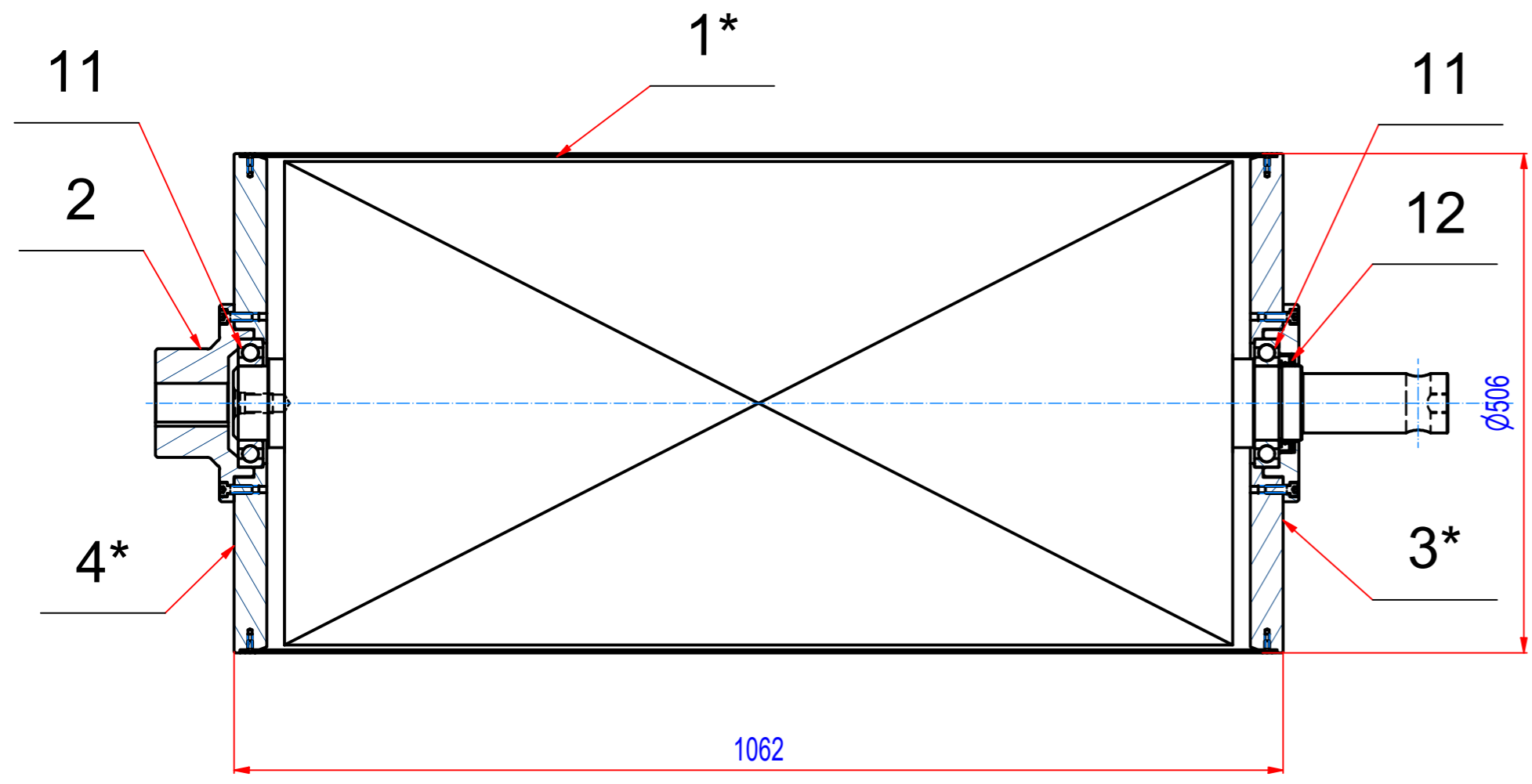

* It is recommended to replace the flanges (POS.3 and 4) and the drum shell (POS.1) at the same time.
The need to fit these parts.
Pos. 14 to 18 are intended for the food industry

POS.	PART NUMBER	DESCRIPTION	MATERIAL	WEIGHT	QTY.
18	A243_000209	Top cleaning strip	FOOD PUR	1	1
17	A143_000308	Bottom cleaning strip-100mm	FOOD PUR	0,1	1
16	A143_000309	Bottom cleaning strip-centre	FOOD PUR	1,2	1
15	A243_000009	Inlet PUR slat	FOOD PUR	0,3	1
14	A243_000109	Front PUR slat	FOOD PUR	1,1	1
12	74_1075131	Sealing ring NBR G 75x100x13		0	1
11	15_0406215	Bearing 6215-2RS1		1,1	2
10	MH07502110	Drive SEW FF67DRN80M4, 0,75kW, i=67,65		48	1
9	A243_000201	Top cleaning strip	PUR	1	1
8	A143_000302	Bottom cleaning strip-100mm	PUR	0,1	2
7	A143_000301	Bottom cleaning strip-centre	PUR	1,2	1
6	A243_000004	Inlet PUR slat	PUR	0,3	1
5	A243_000103	Front PUR slat	PUR	1,1	1
4*	A147_010001	Al front drum1	EN AW-6082 T6	16,1	1
3*	A164_010001	Al front drum SRTK160054	EN AW-6082 T6	16,1	1
2	A164_010003	Driving shaft SRTK160054	S355 (11523)	8,3	1
1*	A243_010200	Shell of SRTK100054	AISI304	40	1

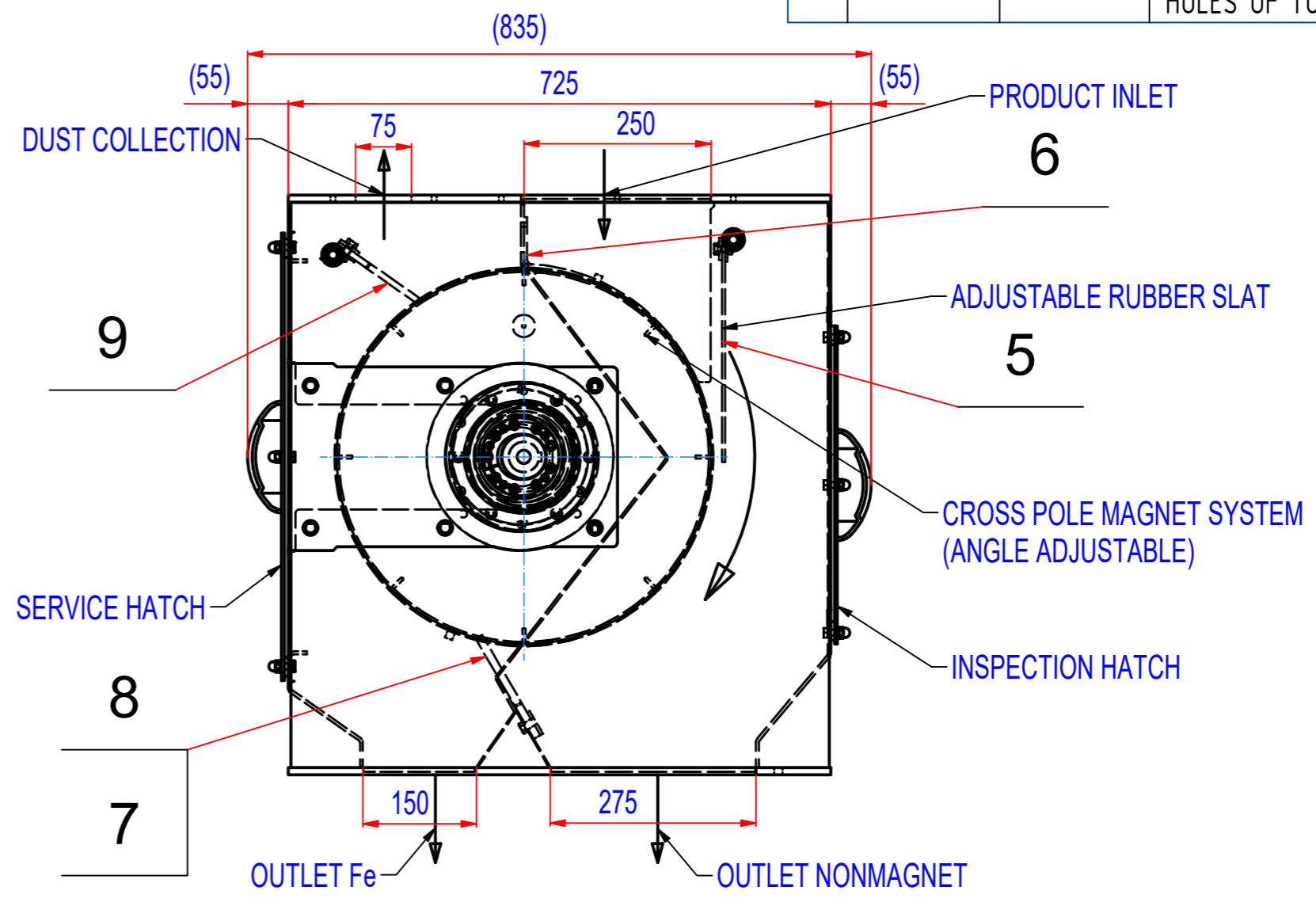
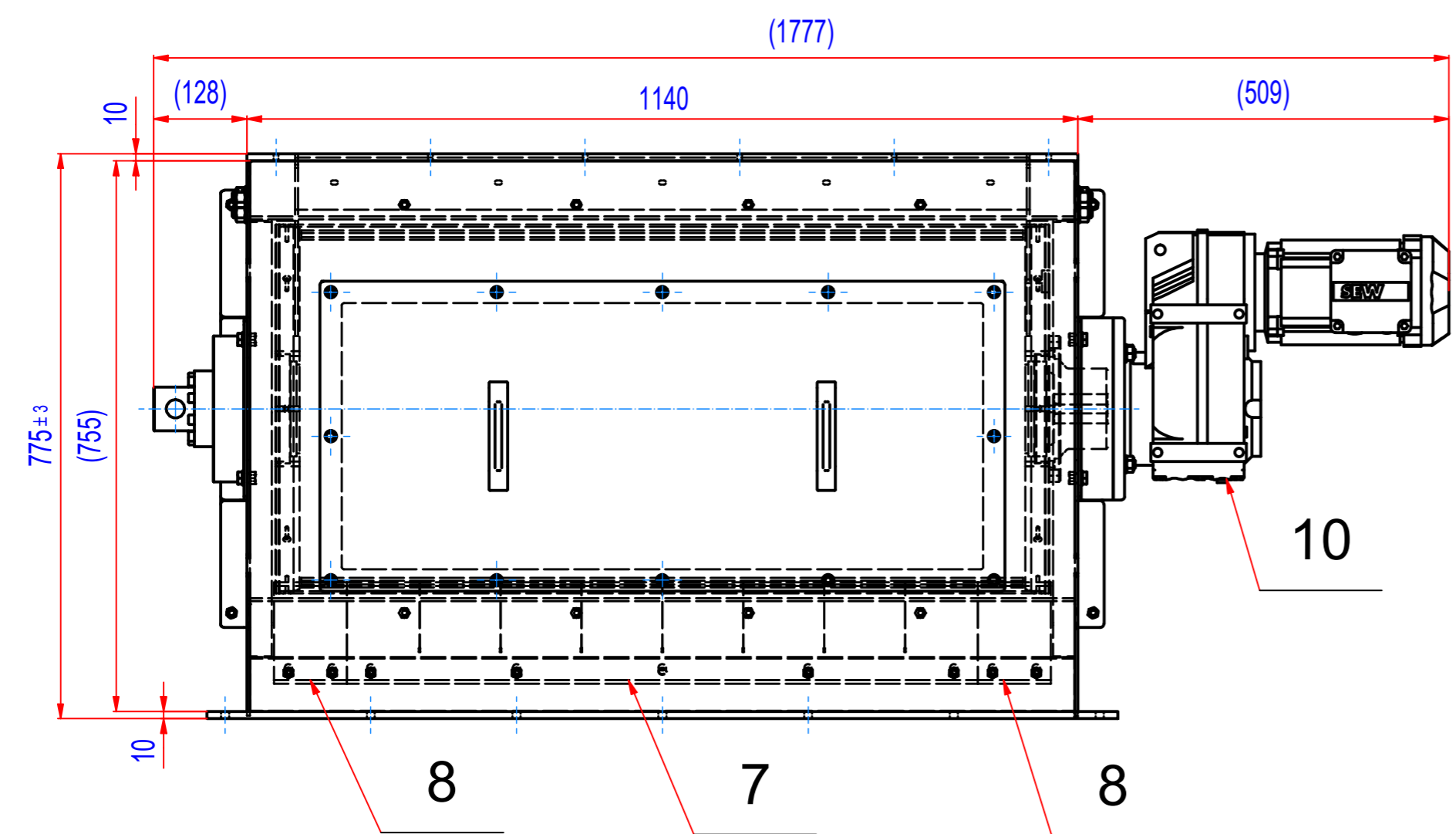
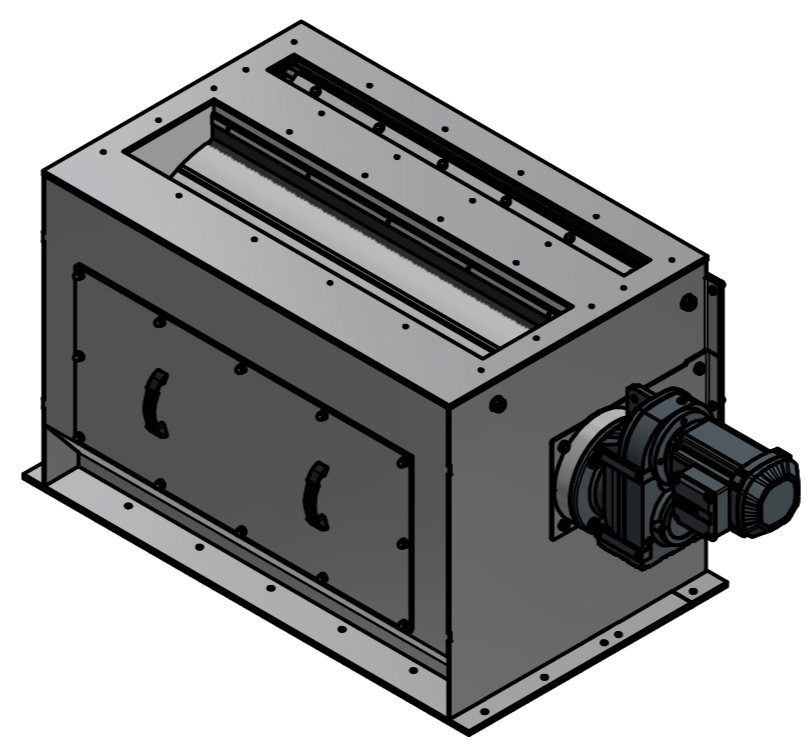

Sheet: A2 Drawn: PH Date: 01.11.2023 Predecessor: 991_000000 Quick search:	Weight (kg): 702,2 Description: SPARE PARTS for drum separator, Comb, D506-1000	Extra info: GOUDSMIT MAGNETICS © All rights reserved. Reproduction is not permitted without written permission of GOUDSMIT Magnetic Systems BV	General tolerance: ISO 2768 - cL Drawn according: ISO268; ISO1101; ISO2553 Status: Customer reference number: Product key: SETK-105-SD-B-30S2-NA-FZB-B-B Part number: SRTK100054 Rev: A
--	--	--	---