

REV	BY	DATE	DESCRIPTION
	LF	24.05.2018	NEW VAULT, WITHOUT CHANGE
A	JK	03.11.2023	DRIVE WAS CHANGED FROM MH07502104 IP54 TO MH07502110 IP55, PRODUCT KEY CORRECTED

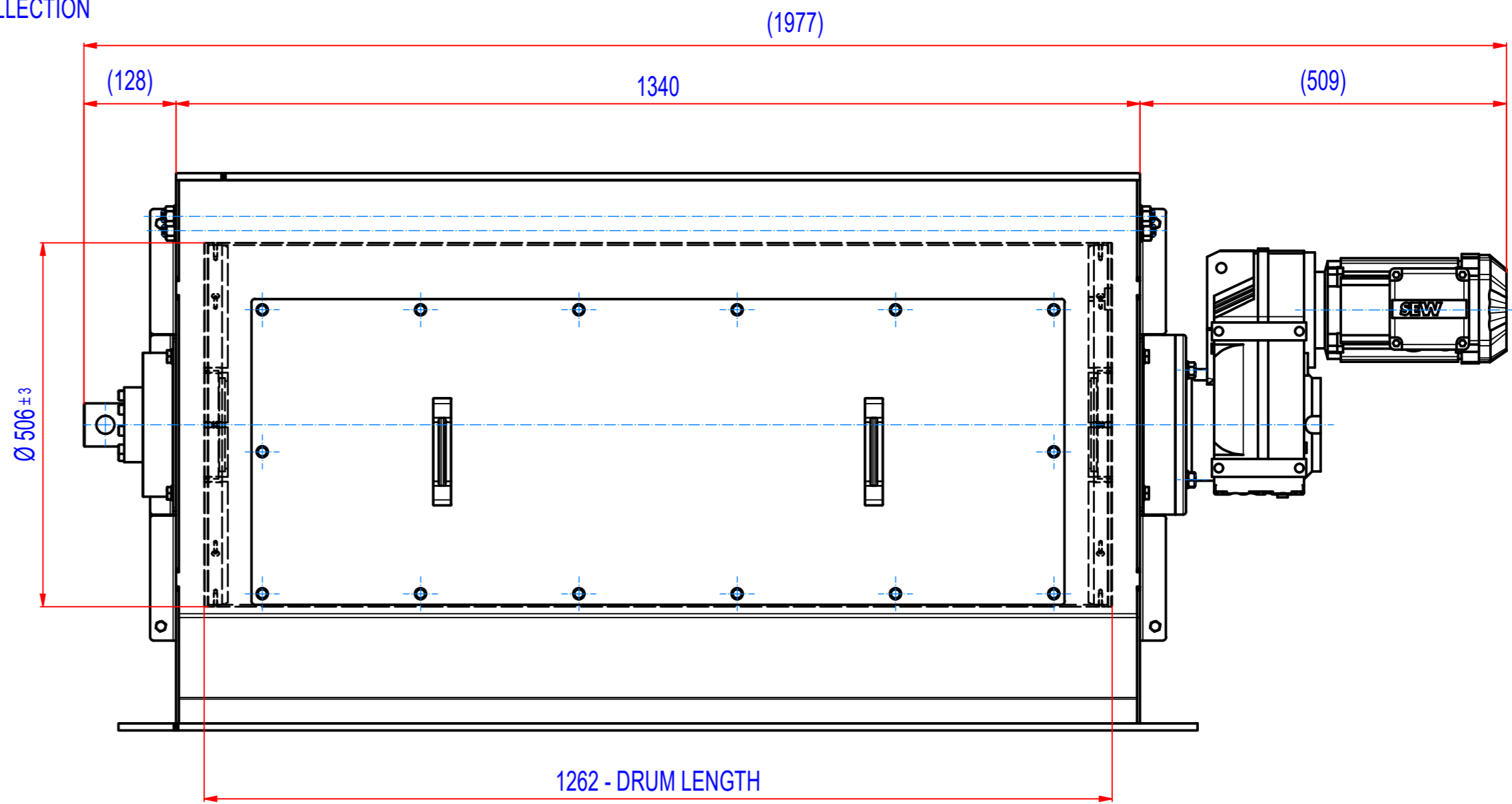

- GEARED BOX SEW FF67DRN80M4, i=67,65 (21RPM),

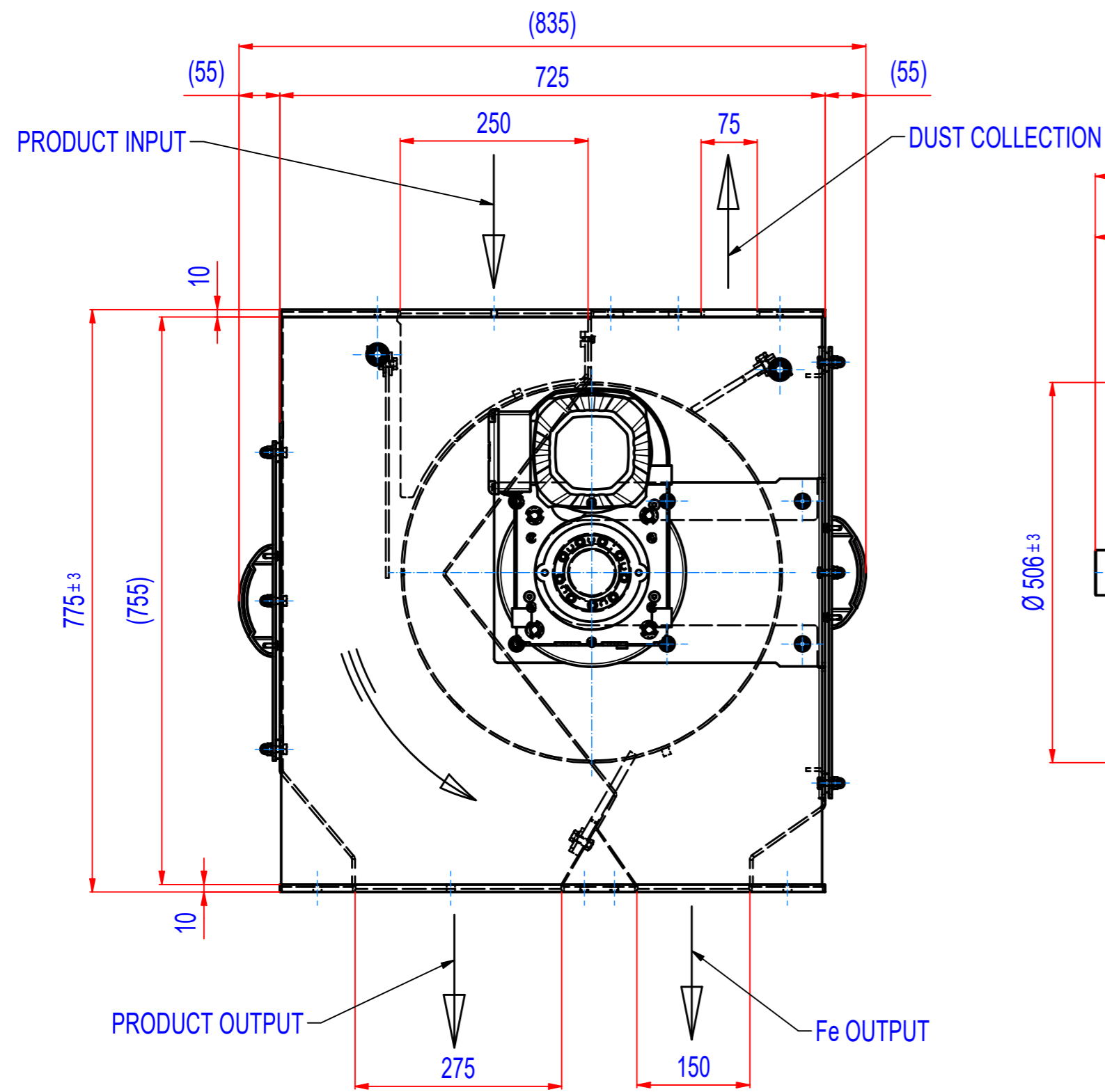
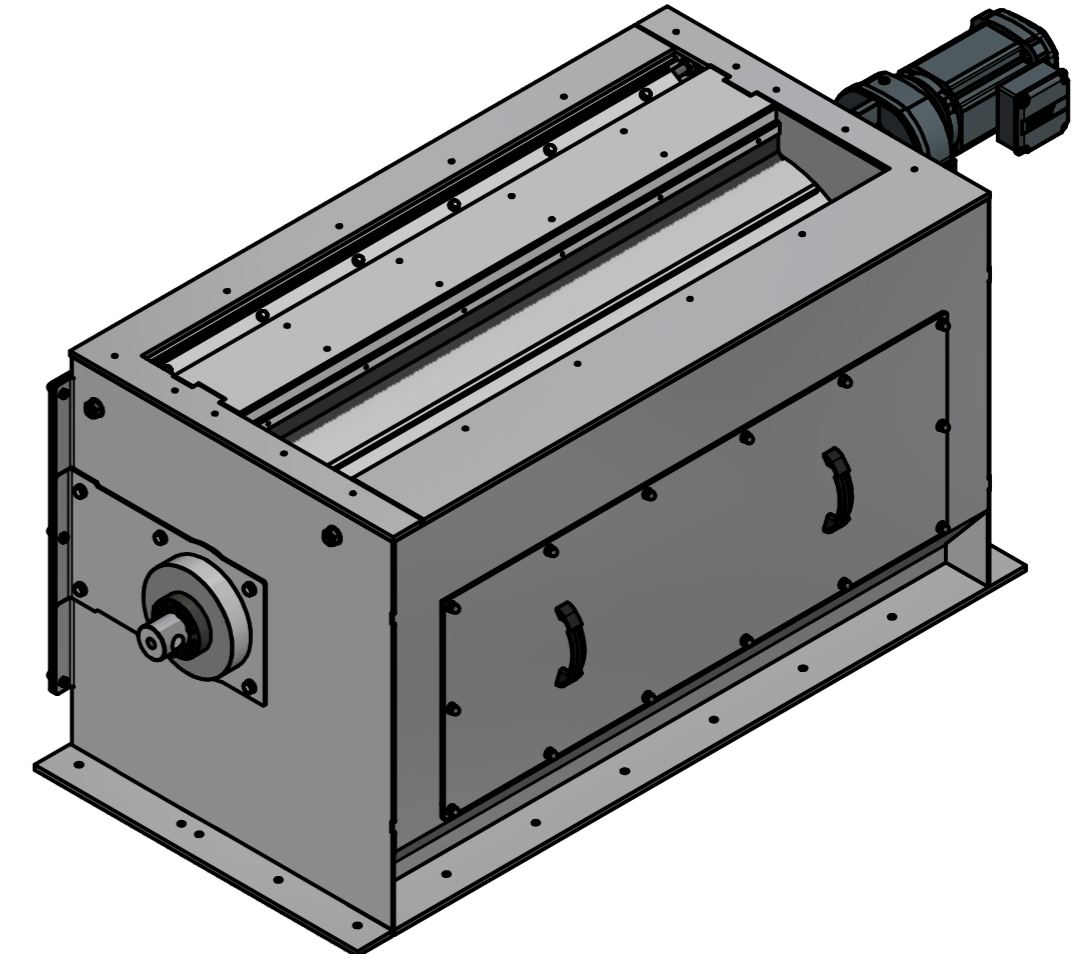

TOP FLANGE

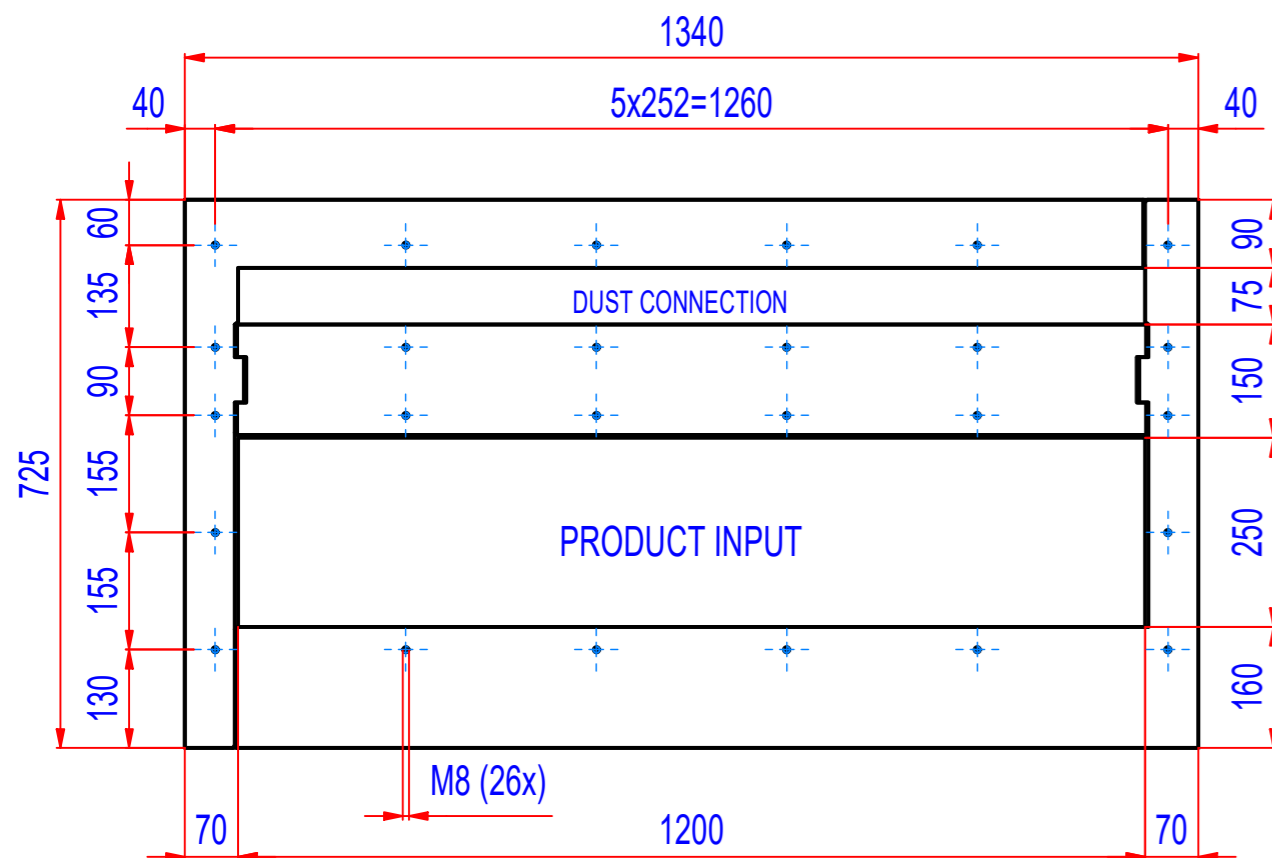

BOTTOM FLANGE

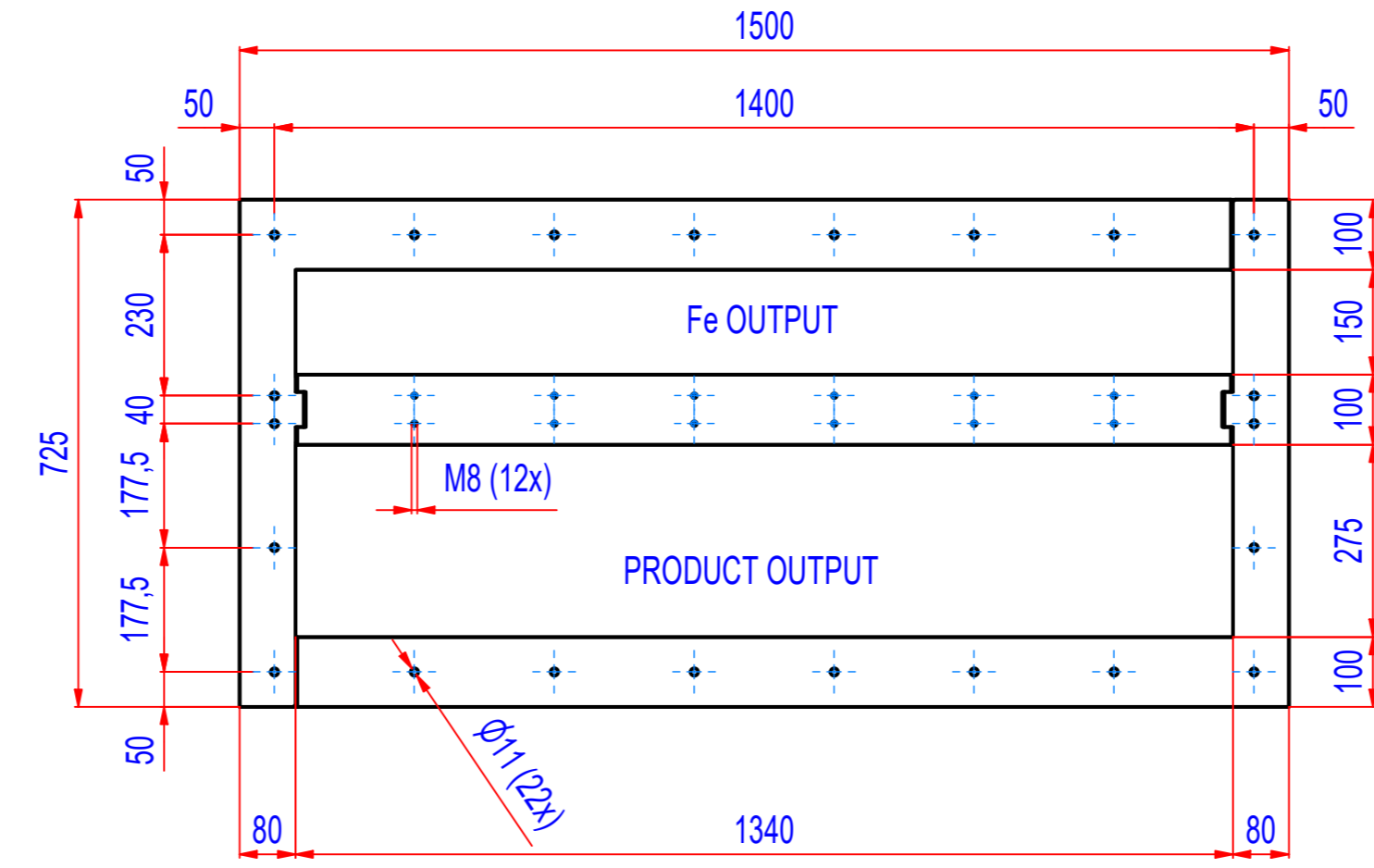

1	A417_000000	SRTK0120054	815,8
POZ./POS.	Č. SOUČÁSTI/ PART NUMBER	POPIS / DESCRIPTION	HMOT./ WEIGHT
Date:	Order ref.:	Responsible person:	
Sheet: A2 Drawn: LF Weight (kg): 815.8 Date: 03.11.2023 Predecessor:	Extra info:	General tolerance: ISO 2768 - cL Drawn according: ISO268; ISO1101; ISO2553 Status:	
Quick search: XSTK			Customer reference number:
Description: Drum separator in housing, Comb, D506-1200	© All rights reserved. Reproduction is not permitted without written permission of GOUDSMIT Magnetic Systems BV		Product key: SETK-125-SD-B-30S2-NA-FZB-B-B Part number: SRTK120054 Rev: A