

REV	BY	DATE	DESCRIPTION
	LF	24.05.2018	NEW VAULT, WITHOUT CHANGE
	PH	11.11.2020	Add note + food slats
A	JIK	03.11.2023	DRIVE WAS CHANGED FROM MH07502104 IP54 TO MH07502110 IP55, PRODUCT KEY CORRECTED

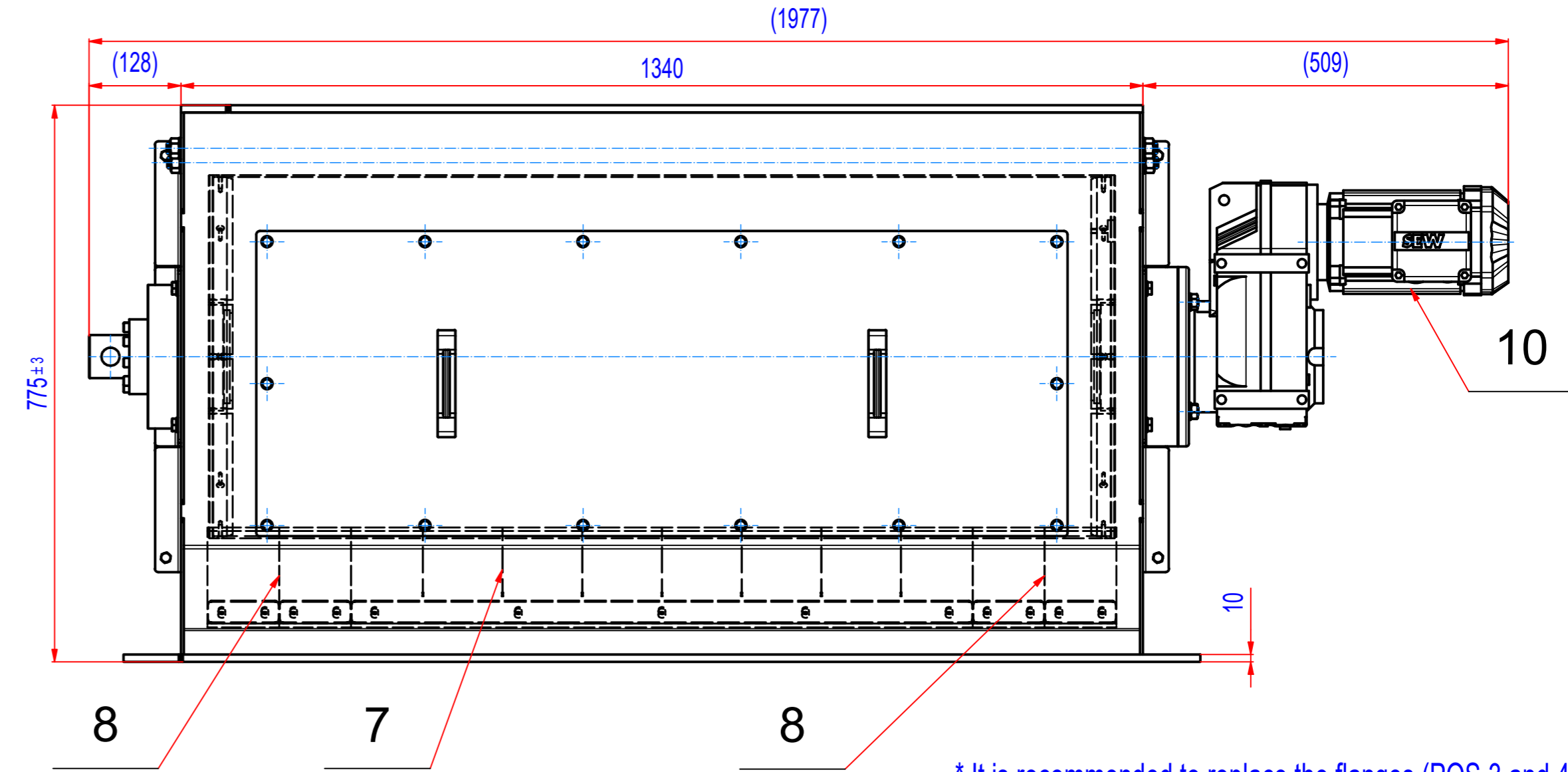

* It is recommended to replace the flanges (POS.3 and 4) and the drum shell (POS.1) at the same time.
The need to fit these parts.
Pos. 14 to 18 are intended for the food industry

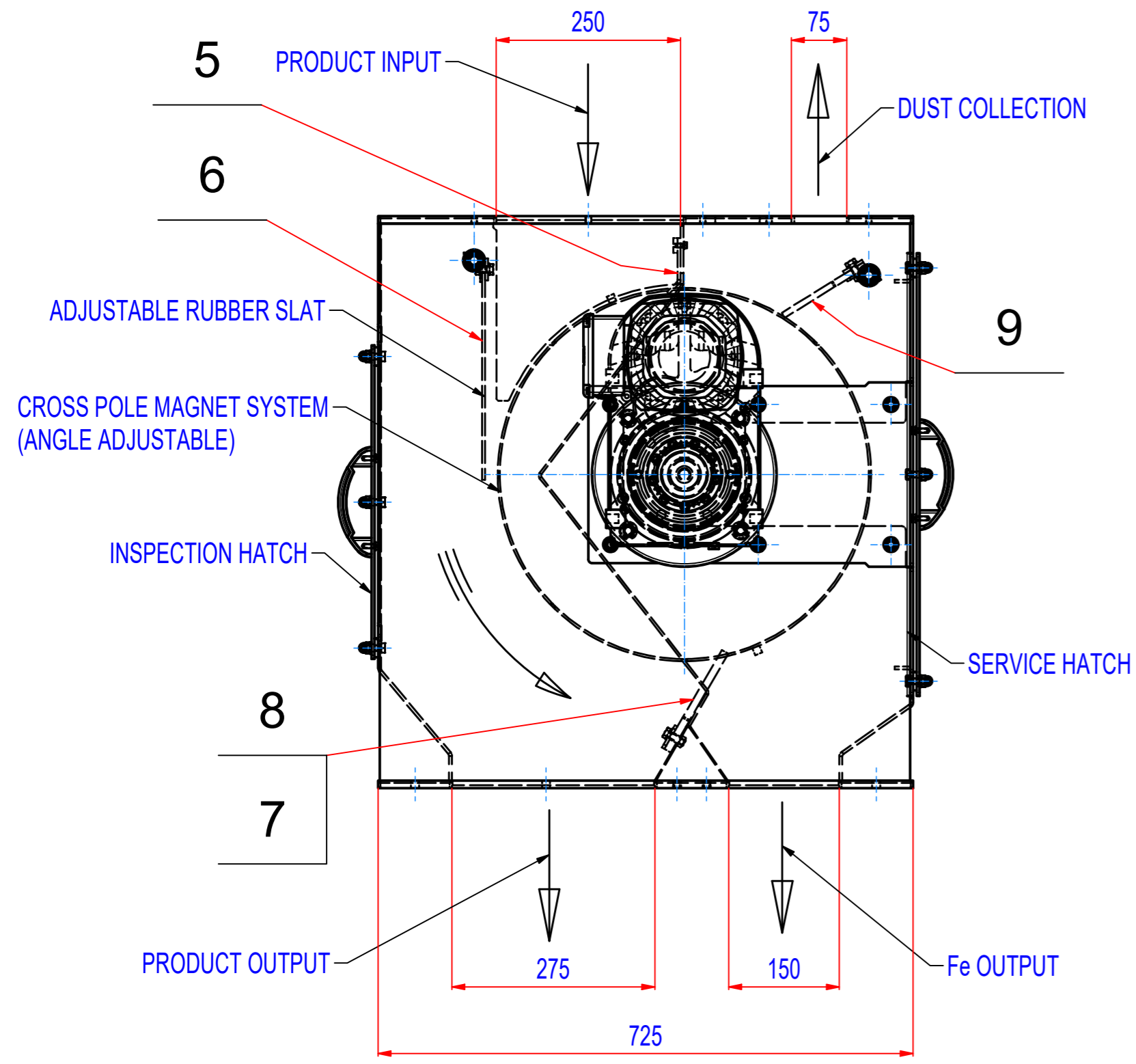
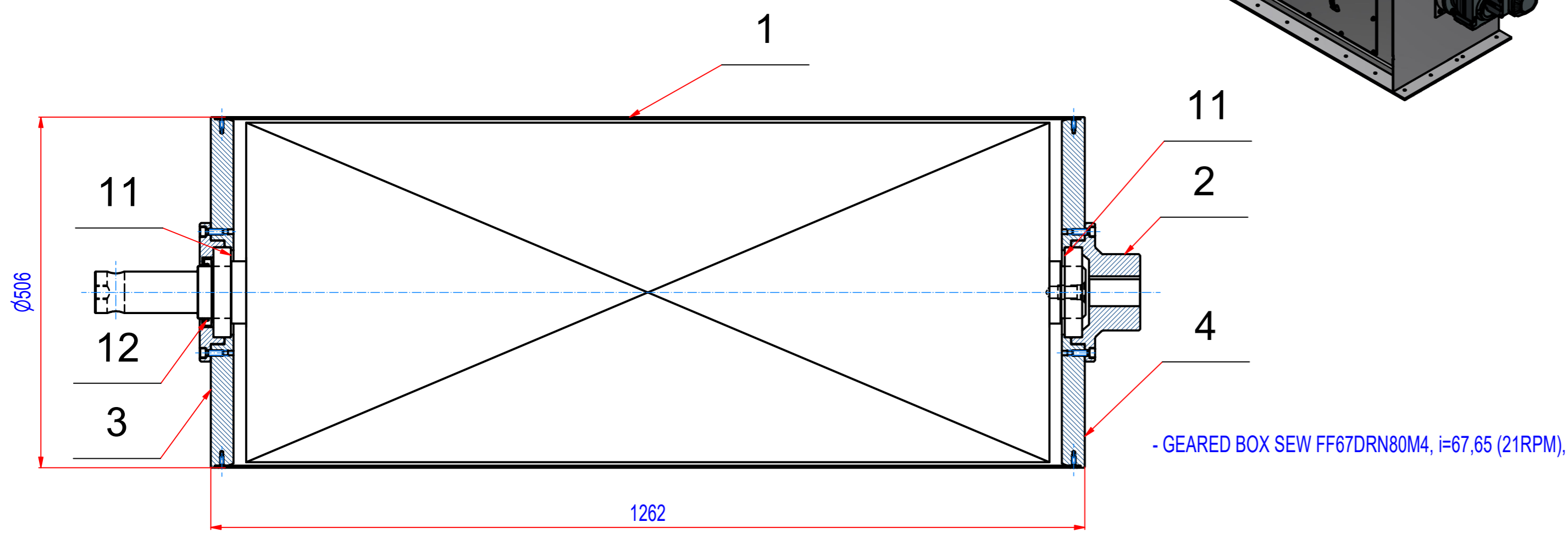
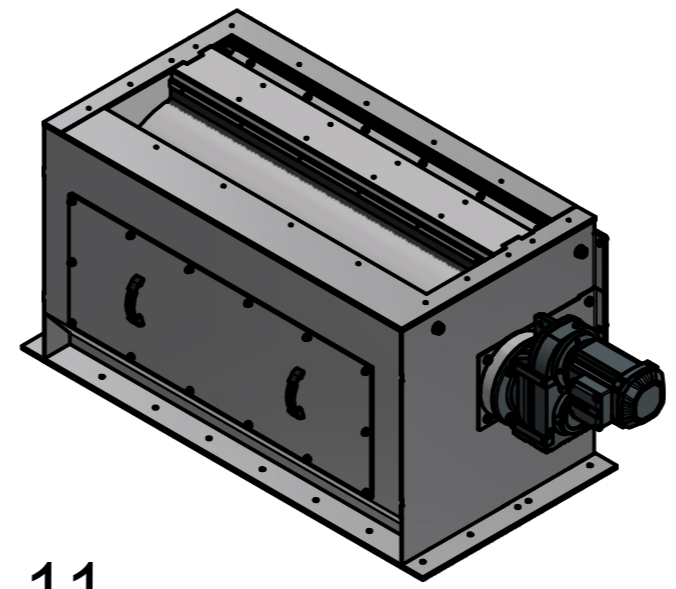

POS.	PART NUMBER	DESCRIPTION	MATERIAL	WEIGHT	QTY.
18	A417_000209	Top cleaning strip	FOOD PUR	1,2	1
17	A143_000308	Bottom cleaning strip-100mm	FOOD PUR	0,1	1
16	A143_000309	Bottom cleaning strip-centre	FOOD PUR	1,2	1
15	A417_000009	Inlet PUR slat	FOOD PUR	0,4	1
14	A417_000109	Front PUR slat	FOOD PUR	1,4	1
12	74_1075131	Sealing ring NBR G 75x100x13		0	1
11	15_0406215	Bearing 6215-2RS1		1,1	2
10	MH07502110	Drive SEW FF67DRN80M4, 0,75kW, i=67,65 (21RPM)		48	1
9	A147_000201	Top cleaning strip	PUR	1,2	1
8	A143_000302	Bottom cleaning strip-100mm	PUR	0,1	4
7	A143_000301	Bottom cleaning strip-centre	PUR	1,2	1
6	A147_000103	Front PUR slat	RUBBER	1,4	1
5	A147_000004	Inlet PUR slat	PUR	0,4	1
4	A147_010001	Al front drum1	EN AW-6082 T6	16,1	1
3	A164_010001	Al front drum SRTK160054	EN AW-6082 T6	16,1	1
2	A164_010003	Driving shaft SRTK160054	S355 (11523)	8,3	1
1	A147_010200	Shell of SRTK120054	AISI304	49,5	1

Sheet: A2 Drawn: LF Date: 03.11.2023 Predecessor:	Weight (kg): 815,8 Quick search: XSTK Description: SPARE PARTS FOR SRTK120054	Extra info: © All rights reserved. Reproduction is not permitted without written permission of GOUDSMIT Magnetic Systems BV	General tolerance: ISO 2768 - cL Drawn according: ISO268; ISO1101; ISO2553 Status: Customer reference number: Product key: SETK-125-SD-B-30S2-NA-FZB-B-B Part number: SRTK120054 Rev: A
---	--	--	---