

REV	BY	DATE	DESCRIPTION
-	PH	12.11.2020	New Vault, old rev.B, Add note + food slats
A	JIK	09.11.2023	DRIVE WAS CHANGED FROM MH07502104 IP54 TO MH07502110 IP55, PRODUCT KEY CORRECTED, HOLES OF FLANGES CHANGED

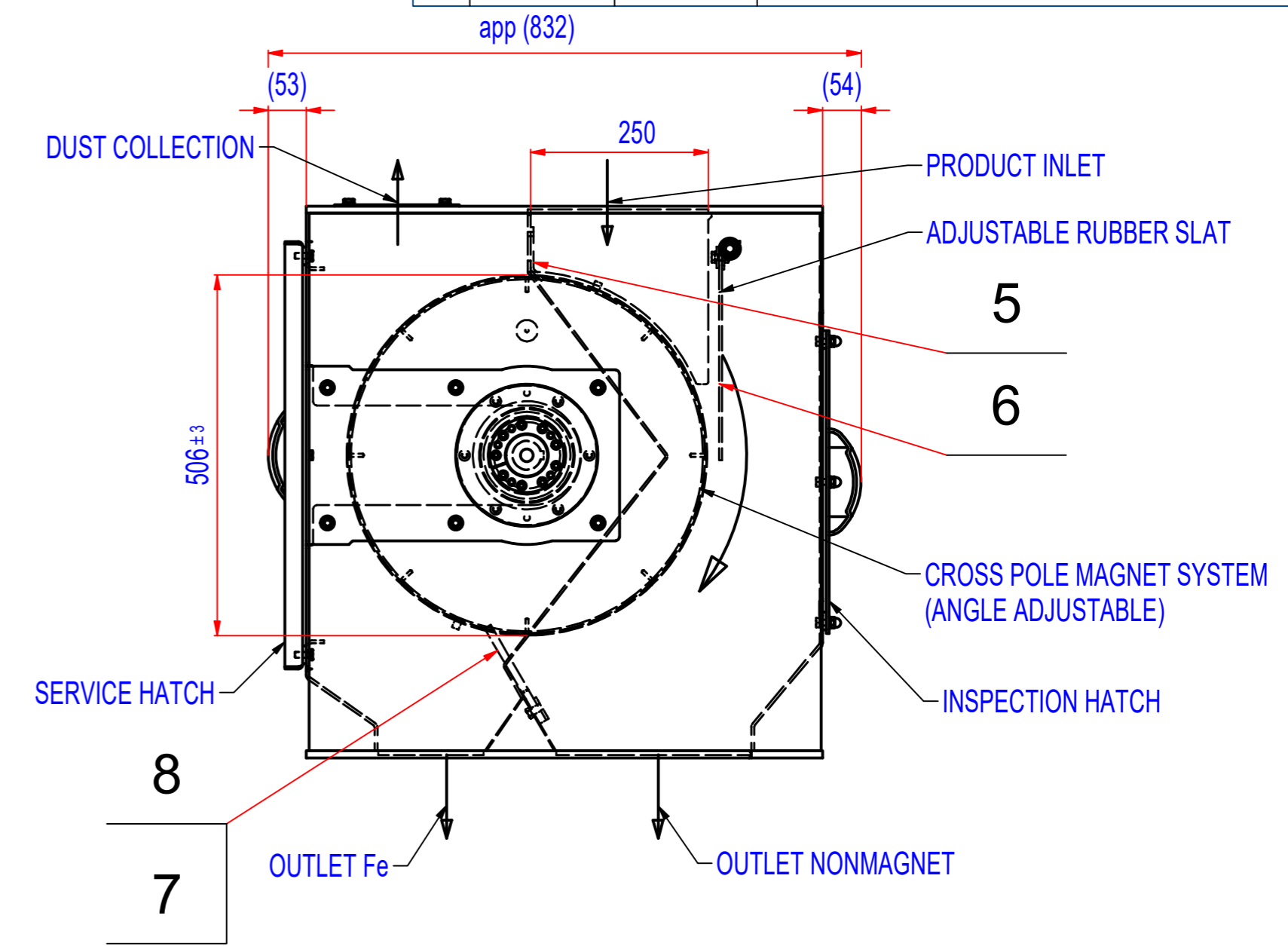

DUST COLLECTION OUTLET SEAL UP

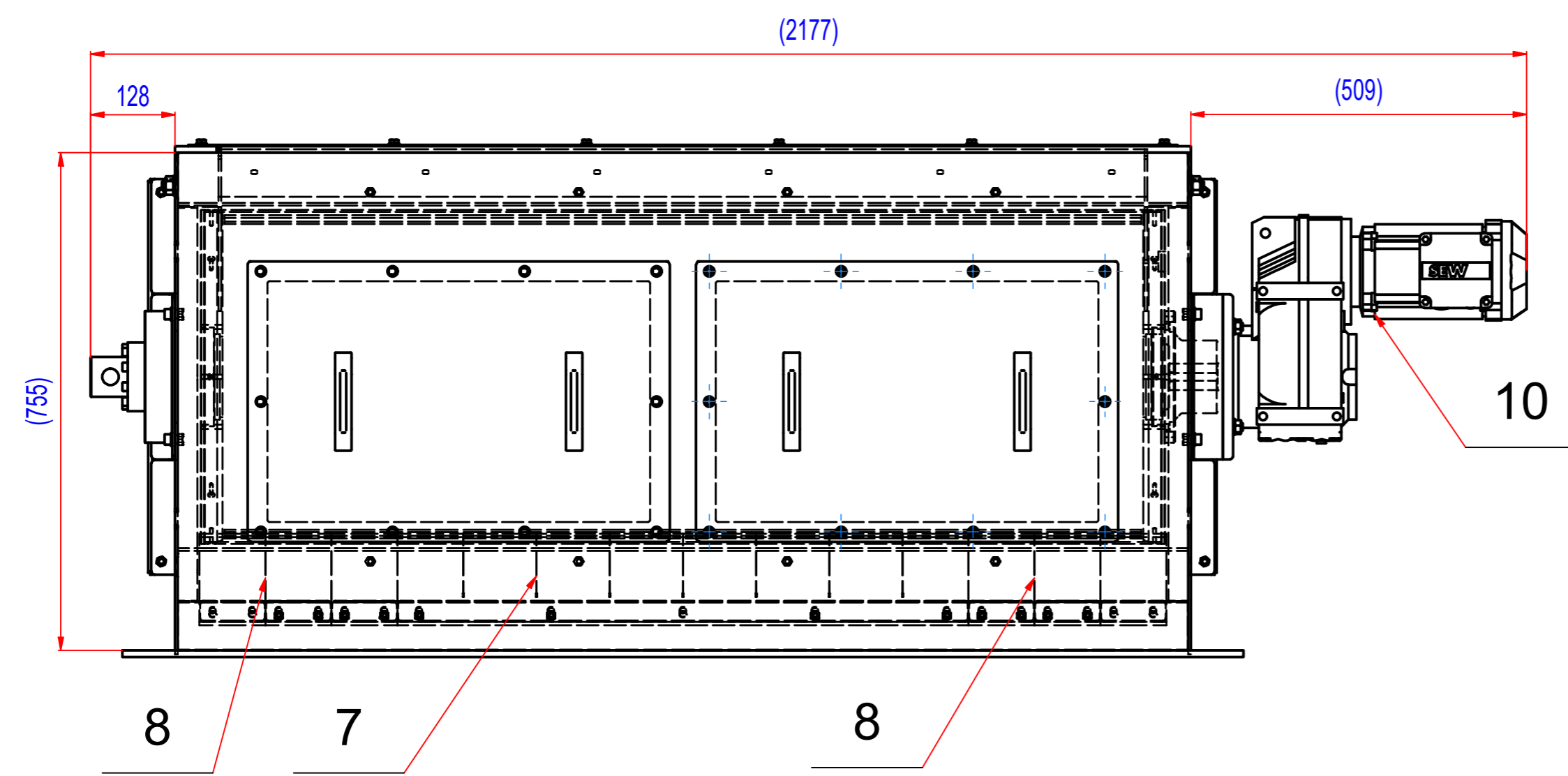
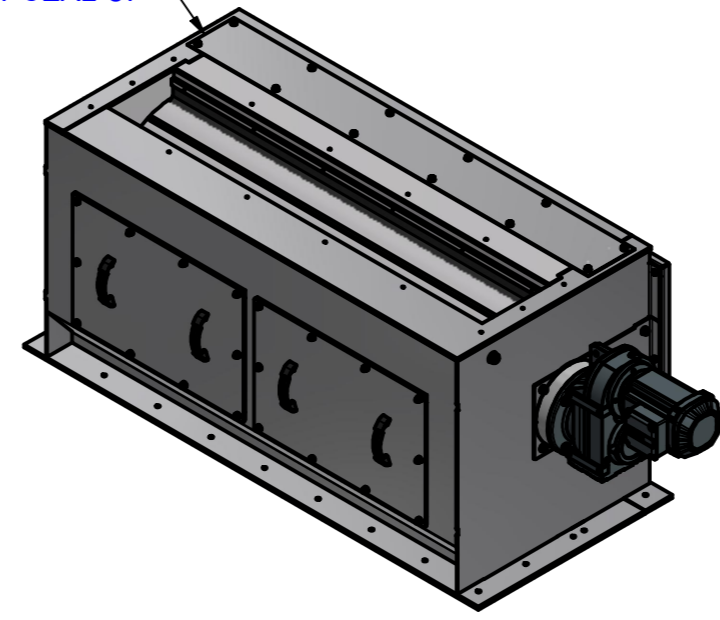

* It is recommended to replace the flanges (POS.3) and the drum shell (POS.1) at the same time.
The need to fit these parts.
Pos. 14 to 17 are intended for the food industry

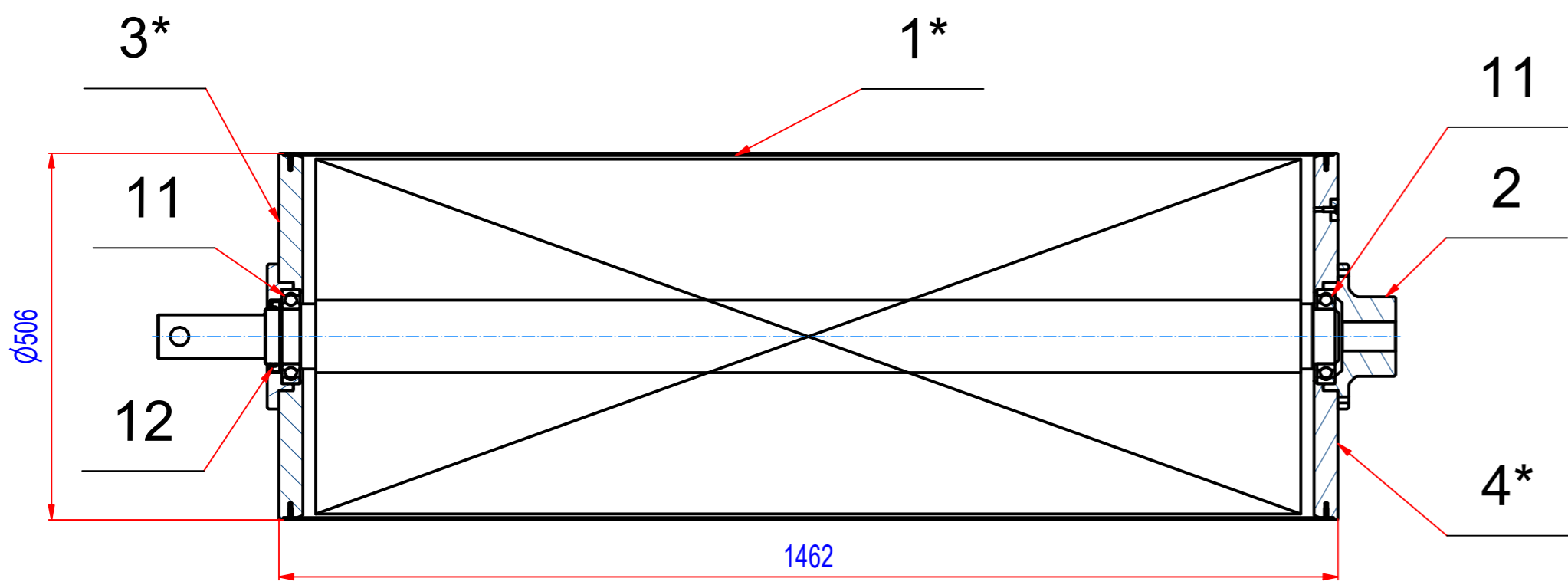

POS.	PART NUMBER	DESCRIPTION	MATERIAL	WEIGHT	QTY.
17	A143_000308	Bottom cleaning strip-100mm	FOOD PUR	0,1	1
16	A143_000309	Bottom cleaning strip-centre	FOOD PUR	1,2	1
15	A143_000009	Inlet PUR slat	FOOD PUR	0,4	1
14	A143_000109	Front PUR slat	FOOD PUR	0,1	1
12	74_1075131	GUFERO NBR G 75x100x13	Pryż	0	1
11	15_0406215	Bearing 6215-2RS1		1,1	2
10	MH07502110	Drive SEW FF67DRN80M4, 0,75kW, i=67,65		48	1
8	A143_000302	Bottom cleaning strip-100mm	PUR	0,1	6
7	A143_000301	Bottom cleaning strip-centre	PUR	1,2	1
6	A143_000103	Front PUR slat	PUR	1,7	1
5	A143_000004	Inlet PUR slat	PUR	0,4	1
4*	A147_010001	Al front drum 1	EN AW-6082 T6	16,1	1
3*	A164_010001	Al front drum SRTK160054	EN AW-6082 T6	16,1	1
2	A164_010003	Driving shaft SRTK160054	S355 (11523)	8,3	1
1*	A143_010200	Shell of SRTK140054	AISI304	56	1

NOTES

-DRIVE SEW FF67DRN80M4, 0,75kW, i=67,65, 20 RPM

Sheet: A2 Drawn: PH Date: 09.11.2023 Predecessor: C99_000000 Quick search:	Extra info: © All rights reserved. Reproduction is not permitted without written permission of GOUDSMIT Magnetic Systems BV	General tolerance: ISO 2768 - cL Drawn according: ISO268; ISO1101; ISO2553 Status: Customer reference number: Product key: SETK-145-SD-B-30S2-NA-FZB-B-B Part number: SRTK140054 Rev: A
Description: Drum separator in housing, Comb, D506-1400		