

REV	BY	DATE	DESCRIPTION
-	LF	18.10.2017	ORIGINAL DRAWING
A	LF	04.06.2018	HOLES IN TOP FLANGE ARE M8 (WAS d11)
B	JK	27.10.2023	DRIVE WAS CHANGED FROM MH07502104 IP54 TO MH07502110 IP55, PRODUCT KEY CORRECTED

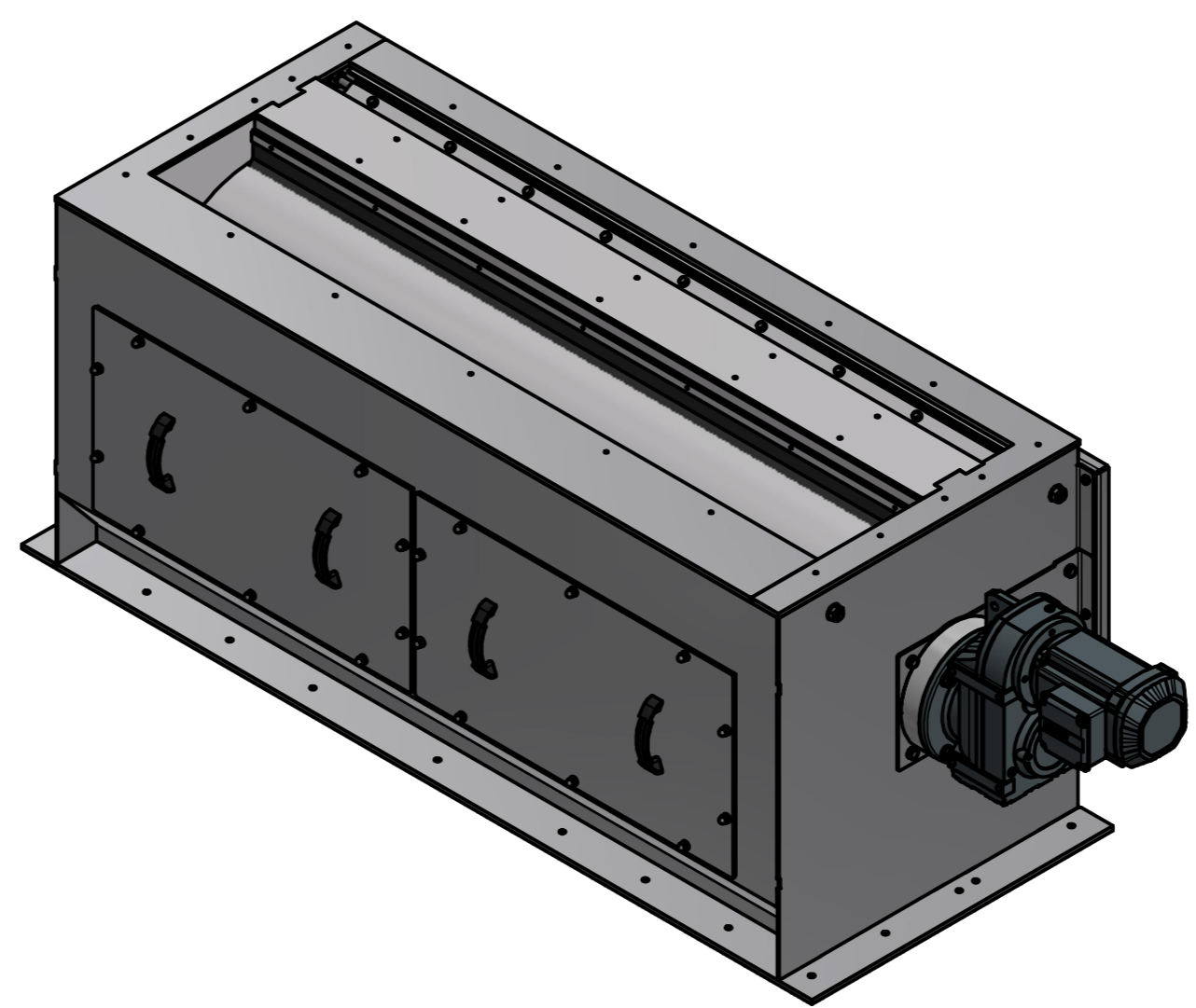
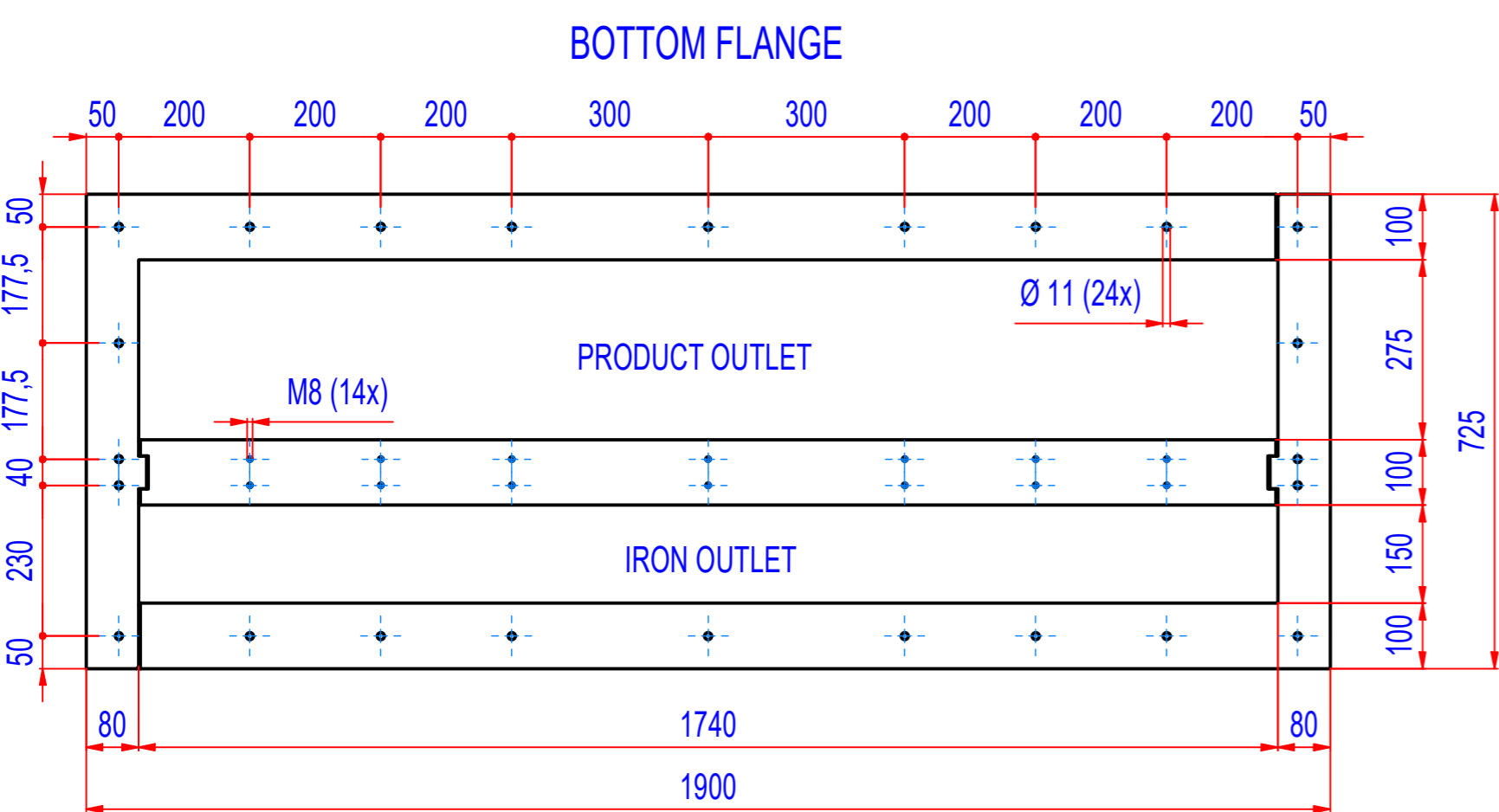
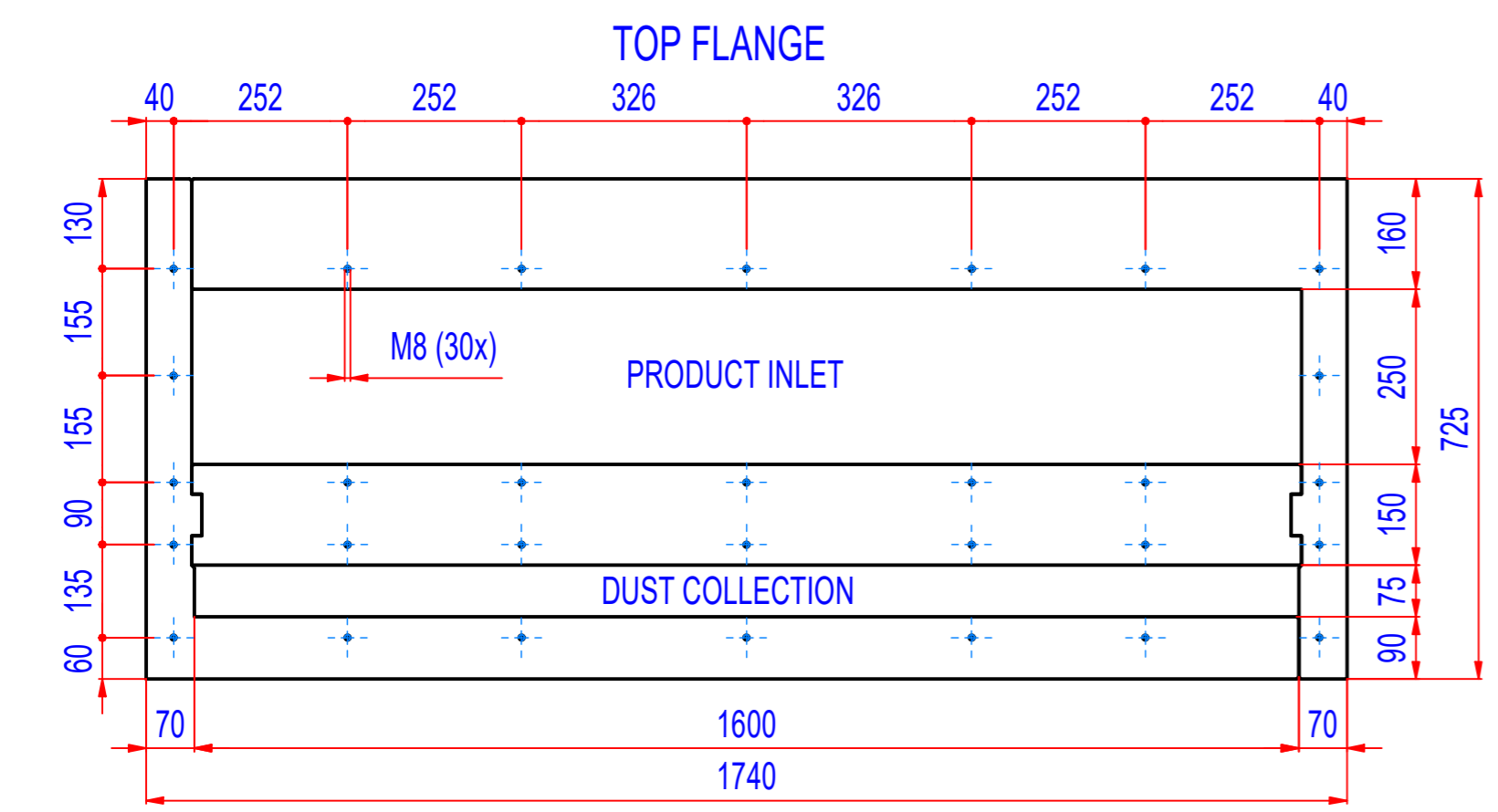
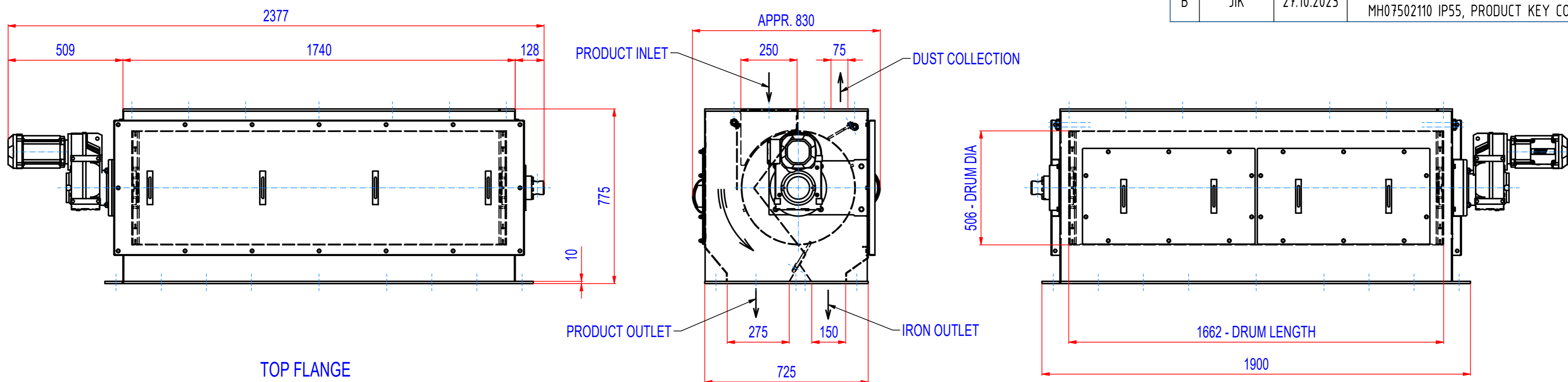

DRIVE: SEW FF67DRN80M4, 21 RPM

1	A164_000000	SRTK160054		1018,8	1
POZ.	Č. SOUČÁSTI	POPIS	MATERIÁL	HMOT.	MN.
Date:	Order ref.:	Responsible person:			
Drawn: LF	Weight (kg): 1018.8	Extra info:	General tolerance: ISO 2768 - cL		
Date: 27.10.2023	Predecessor:		Drawn according: ISO268; ISO1101; ISO2553		
Quick search: XSTK D506	Description: Drum separator in housing, Comb, D506-1600		Status:		
		© All rights reserved. Reproduction is not permitted without written permission of GOUDSMIT Magnetic Systems BV		Customer reference number:	
				Product key: SETK-165-SD-B-30S2-NA-FZB-B-B	
				Part number: SRTK160054 Rev: B	