

REV	BY	DATE	DESCRIPTION
-	LF	18.10.2017	ORIGINAL DRAWING
A	LF	04.06.2018	HOLES IN TOP FLANGE ARE M8 (WAS d11)
	PH	13.11.2020	Add note + food slats
B	JIK	27.10.2023	DRIVE WAS CHANGED FROM MH07502104 IP54 TO MH07502110 IP55, PRODUCT KEY CORRECTED

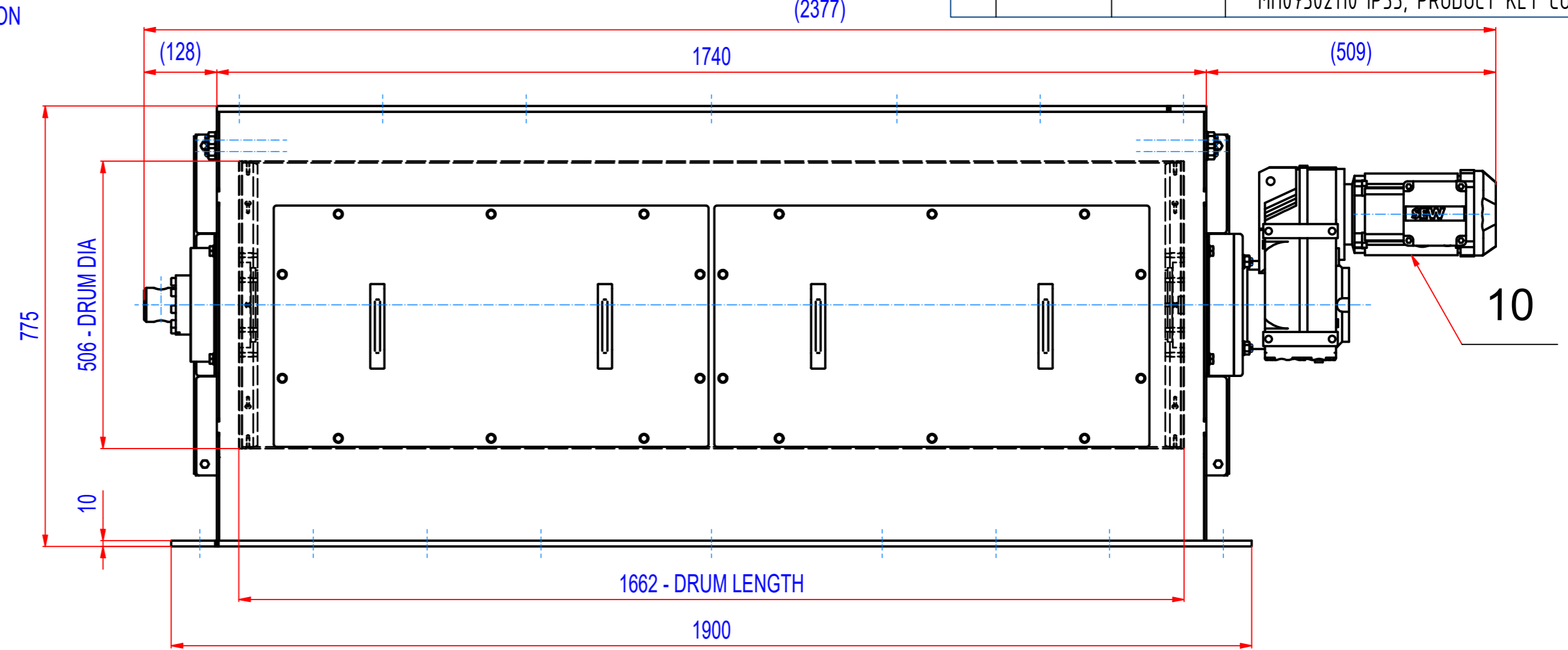

* It is recommended to replace the flanges (POS.3 and 4) and the drum shell (POS.1) at the same time.
The need to fit these parts.
Pos. 14 to 18 are intended for the food industry

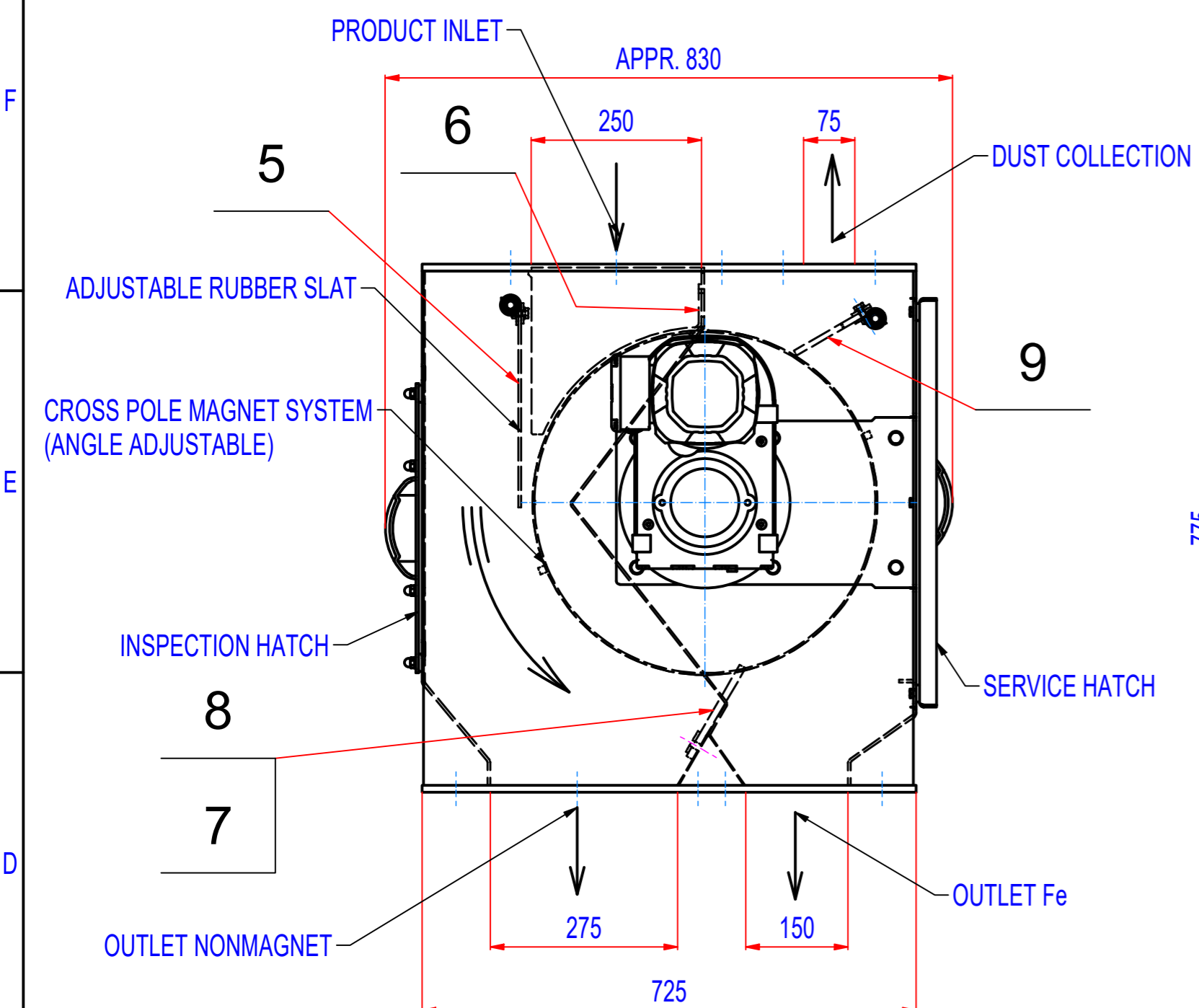
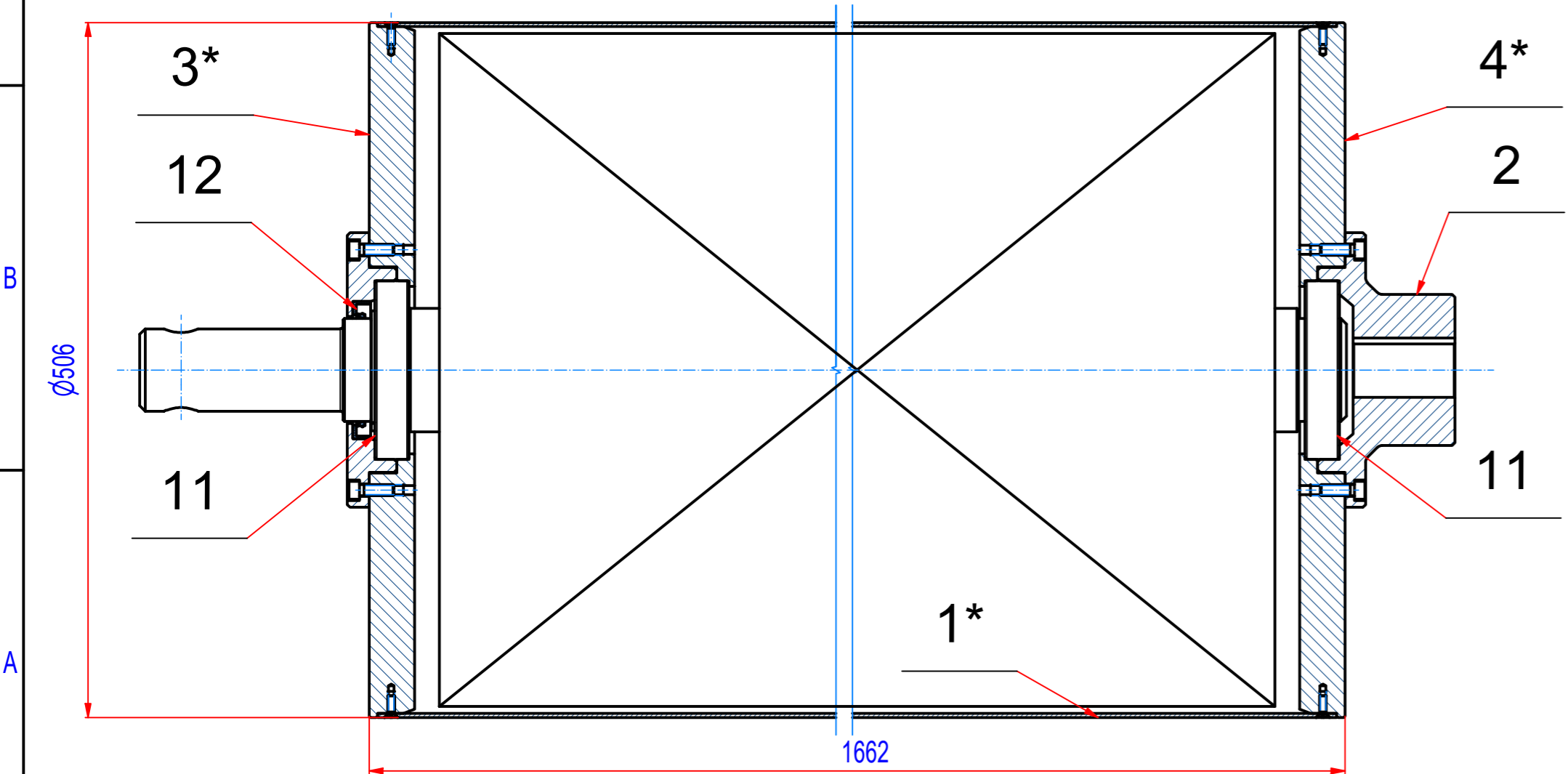
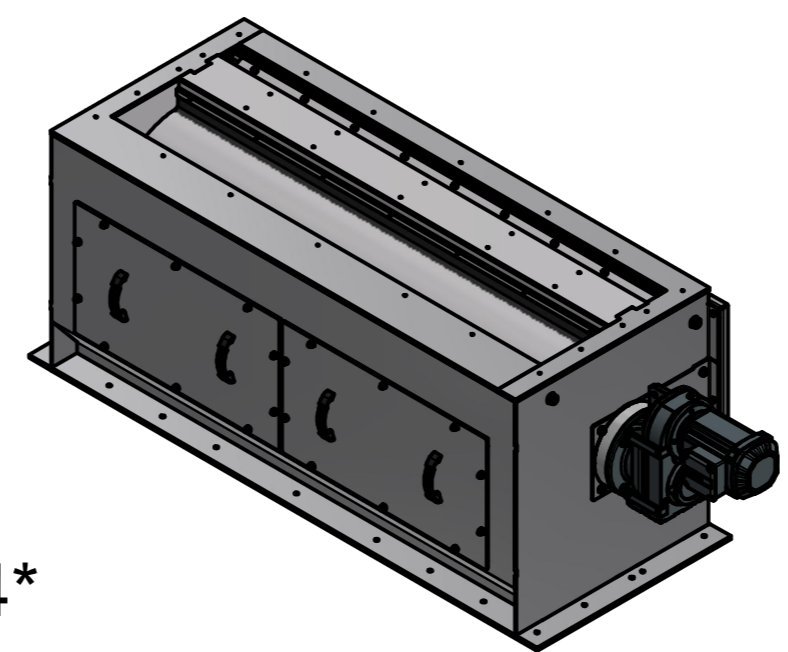

DRIVE: SEW FF67DRN80M4, 21 RPM

POS.	PART NUMBER	DESCRIPTION	MATERIAL	WEIGHT	QTY.
18	A164_050009	Top cleaning strip	FOOD PUR	1,6	1
17	A143_000308	Bottom cleaning strip-100mm	FOOD PUR	0,1	8
16	A143_000309	Bottom cleaning strip-centre	FOOD PUR	1,2	1
15	A164_000009	Inlet PUR slat	FOOD PUR	0,5	1
14	A164_040009	Front PUR slat	FOOD PUR	1,8	1
12	74_1075131	Sealing ring NBR G 75x100x13		0	1
11	15_0406215	Bearing 6215-2RS1		1,1	2
10	MH07502110	Drive SEW FF67DRN80M4, 0,75kW, i=67,65 (21RPM)		48	1
9	A164_050001	Top cleaning strip	PUR	1,6	1
8	A143_000302	Bottom cleaning strip-100mm	PUR	0,1	8
7	A143_000301	Bottom cleaning strip-centre	PUR	1,2	1
6	A164_000001	Inlet PUR slat	PUR	0,5	1
5	A164_040001	Front PUR slat	PUR	1,8	1
4*	A147_010001	Al front drum1	EN AW-6082 T6	16,1	1
3*	A164_010001	Al front drum SRTK160054	EN AW-6082 T6	16,1	1
2	A164_010003	Driving shaft SRTK160054	S355 (11523)	8,3	1
1*	A164_010300	Shell of SRTK160054	AISI304	65,4	1

Sheet: A2 Drawn: LF Date: 27.10.2023 Predecessor:	Weight (kg): 1018,8 GOUDSMIT MAGNETICS © All rights reserved. Reproduction is not permitted without written permission of GOUDSMIT Magnetic Systems BV	General tolerance: ISO 2768 - cL Drawn according: ISO268; ISO1101; ISO2553 Status: Customer reference number: Product key: SETK-165-SD-B-30S2-NA-FZB-B-B Part number: SRTK160054 Rev: B
Quick search: XSTK D506 Description: SPARE PARTS FOR SRTK160054		Part number: SRTK160054 Rev: B