

REV	DATE	BY	DESCRIPTION
A	16-10-2013	AvD	CLAMPING BLOCK (IN ITEM 9) AND MAGNET MOUNTS (IN ITEM 3) CHANGED
B	18-3-2014	AvD	ITEM 4 REPLACED: A140077 WAS A120739
C	17-10-2018	CR	TYPE PLATE AND WARNING STICKERS ADDED

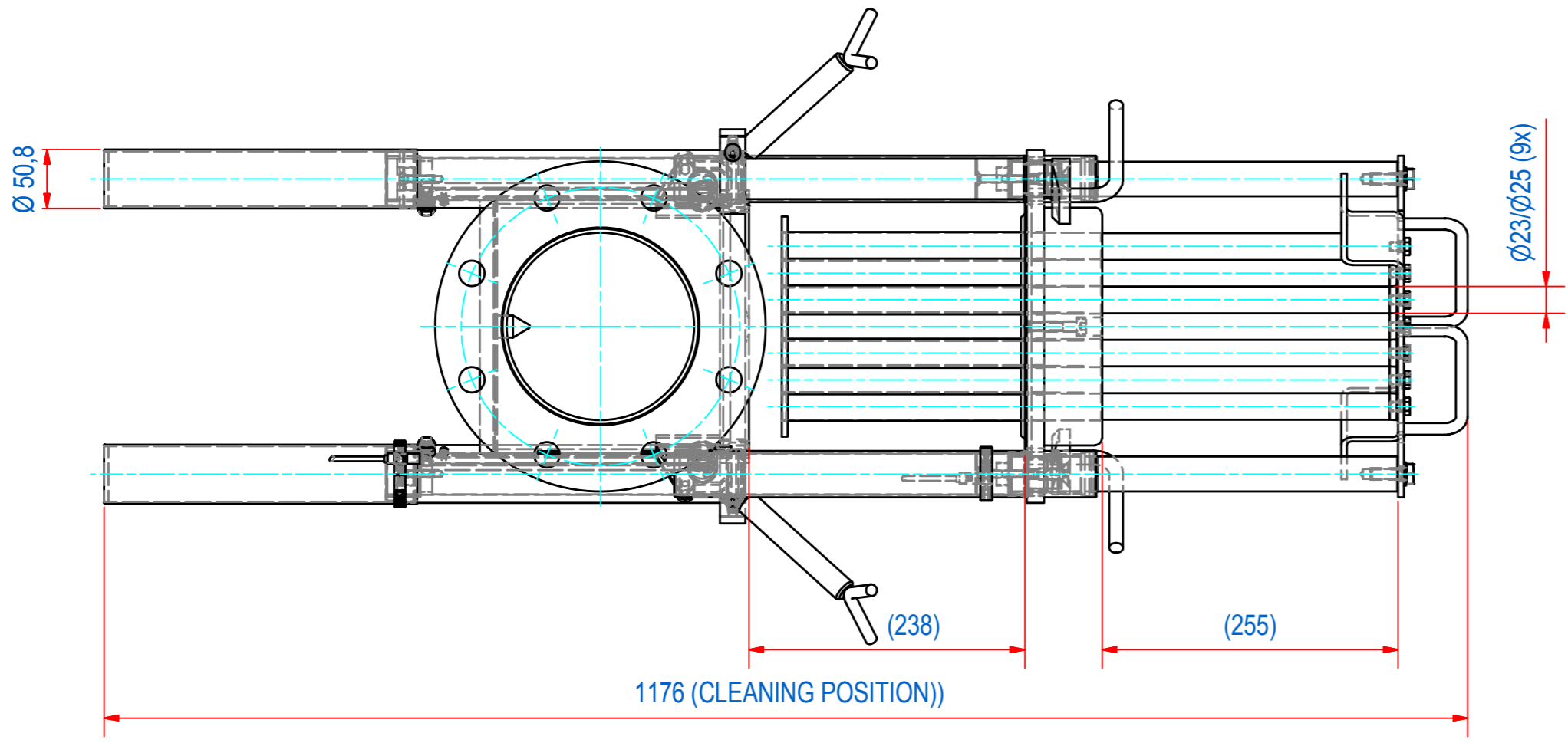
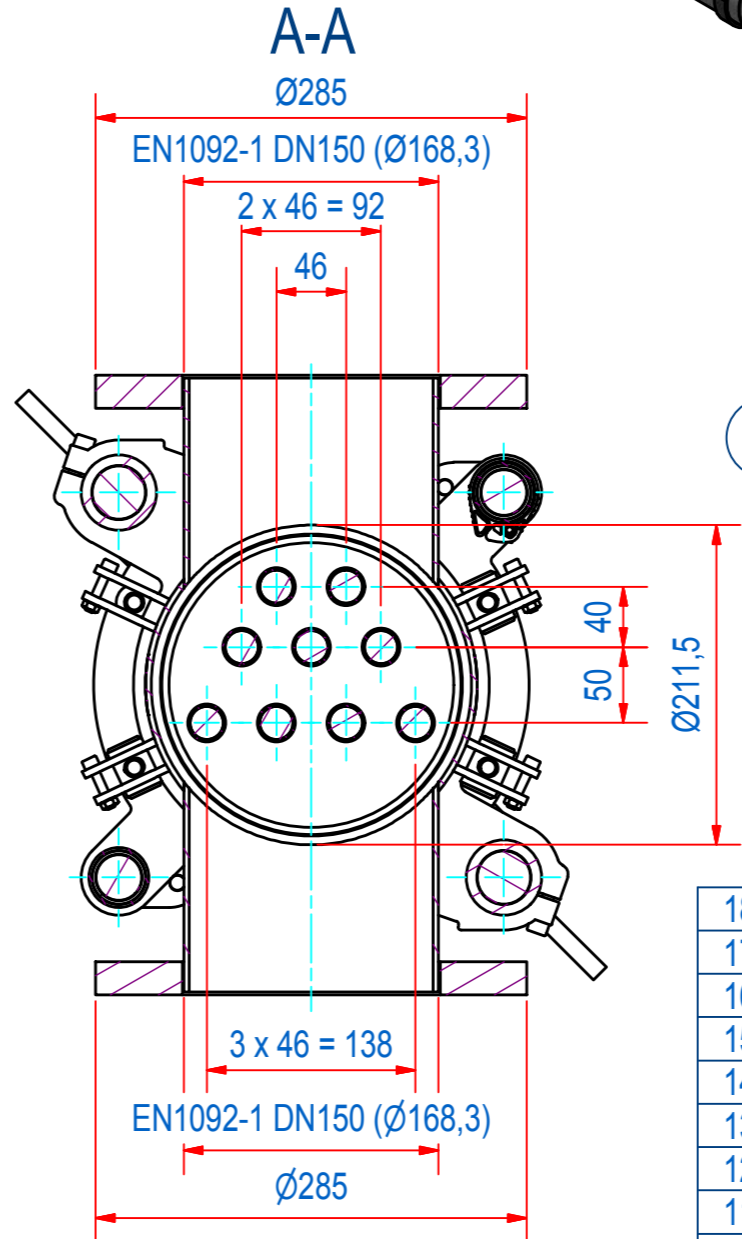
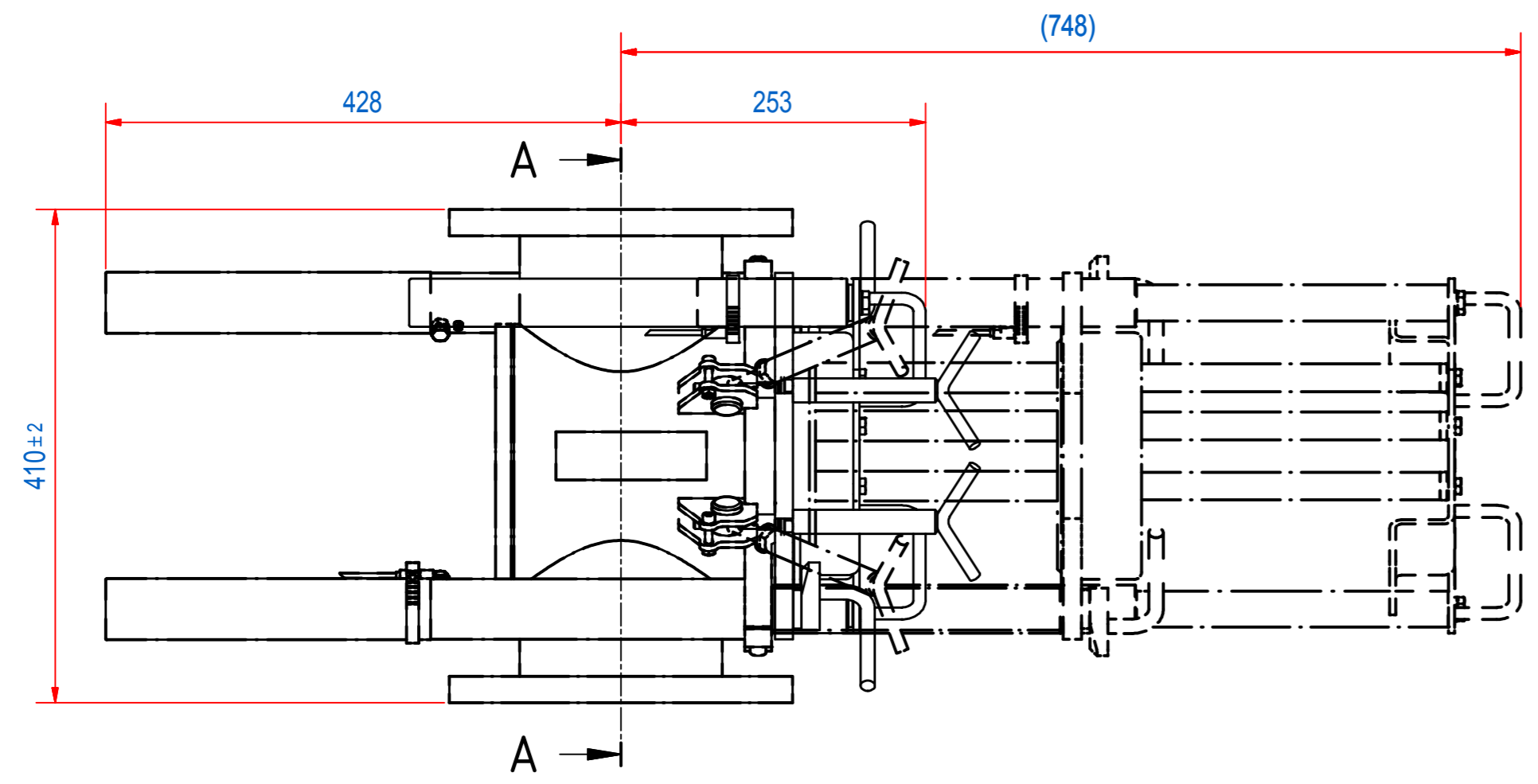
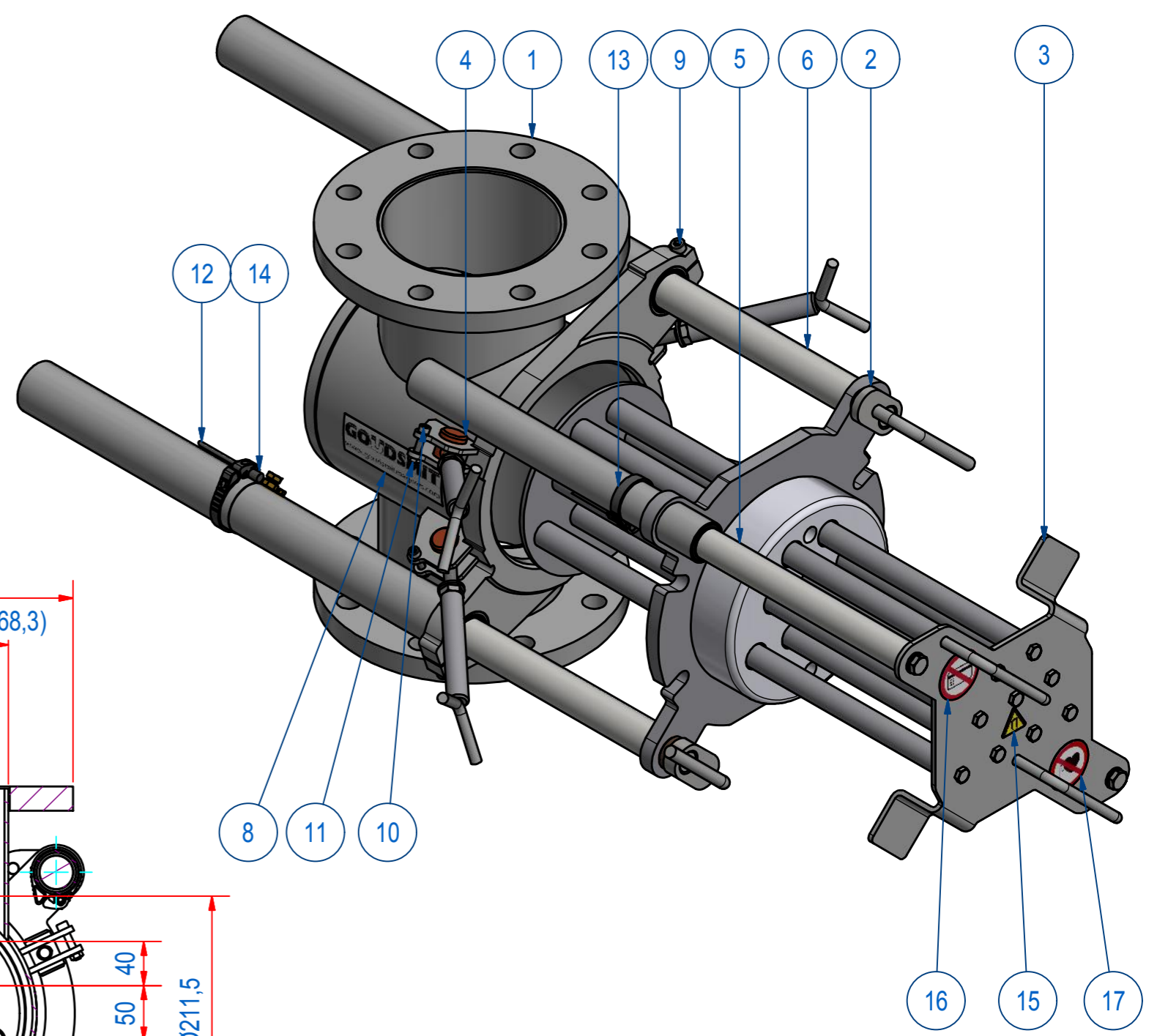
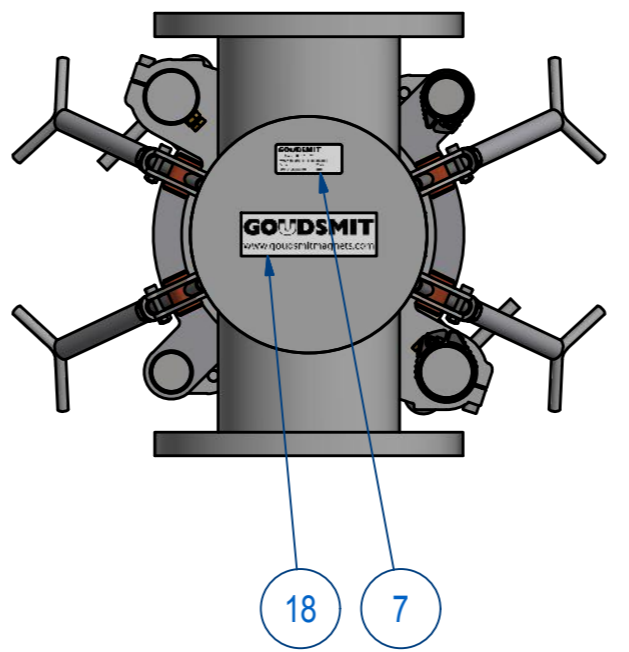
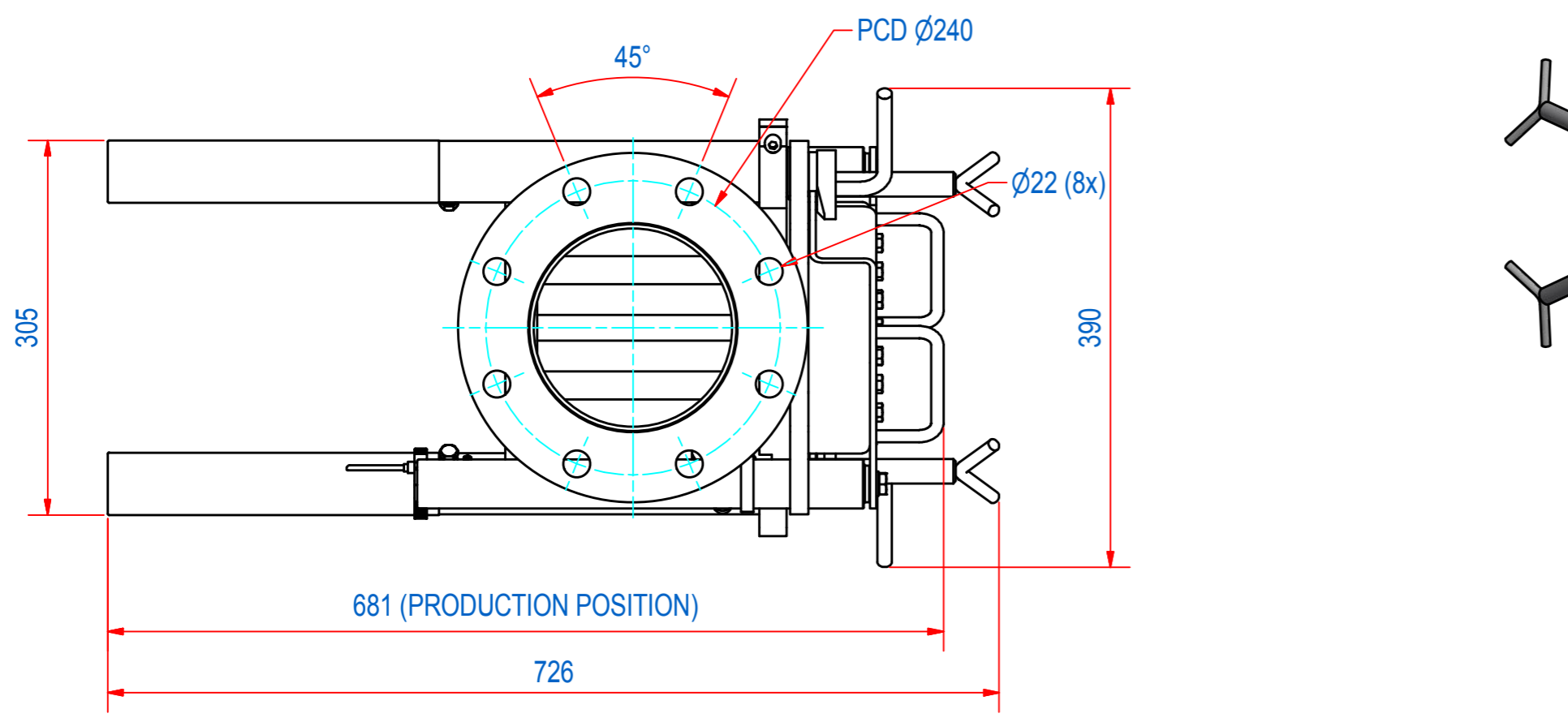

ITEM	QTY	PART NUMBER	DESCRIPTION	Dimensions
18	1	1215.00407	NAME PLATE GOUDSMIT 125x40	
17	1	1000.20056	STICK. PACEMAKER FORB. D=50	
16	1	1000.20055	STICKER MAGN. CARD FORB. D=50	
15	1	1000.20027	STICKER MAGNETIC FIELD 30mm	
14	1	83.9900104	MOUNTING PROXY SENSOR CRSMBR-50	
13	1	83.9900105	MOUNTING PROXY SENSOR CRSMBR-40	
12	2	83.9900106	SENSOR CRSMEO-4-K-LED-24	
11	4	60.0300006	NUT, HEX M6 - A4	M6
10	4	51.0306030	SCREW, HEX SH M6 x 30 - A4	M6 x 30
9	2	51.0208030	SCREW, HEX SH M8 x 30 - A2	M8 x 30
8	2	E0092760	STICKER SFD-080 GSM	
7	1	E0086453	TYPE PLATE FILTER SFN	
6	2	A120943	FS150 GUIDING ROD D35	
5	2	A120927	FS150 MAGNET PLATE ROD	
4	4	A140077	CF000 TOGGLE M12	
3	1	A140177	FS150 MAGNET PLATE ASSY	
2	1	A140175	FS150 EXTRACTOR ASSY	
1	1	A140159	FS150 FILTER POT MILLING	

RAW MAT.	QTY	MAT. NUMBER	MAT. DESCRIPTION	LENGTH (mm)	WIDTH (mm)
1	1				

Sheet: A2	Extra info:	General tolerance: ISO 2768 - mK
Drawn: AvD	Weight (kg): 73,5	Drawn according: ISO268; ISO1101; ISO2553
Date: 5-4-2013		Status: Standard
Spare part: False		Customer reference number:
Quick search: FSN150	GOUDSMIT MAGNETIC SYSTEMS	File number: SSFNG15038 Rev: C
Description: SFNG-150-IF-09E-HT-F1m-S-B-B	© All rights reserved. Reproduction is not permitted without written permission of GOUDSMIT Magnetic Systems BV	Part number: SSFNG15038 Rev: C