

REV	DATE	BY	DESCRIPTION
-	19-7-2013	AvD	NEW REVISION VAULT, NOTHING CHANGED, OLD REV WAS A
A	10-10-2013	AvD	CLAMPING BLOCK (IN ITEM 8) AND MAGNET MOUNTS (IN ITEM 3) CHANGED
B	16-10-2018	CR	TYPE PLATE AND WARNING STICKERS ADDED

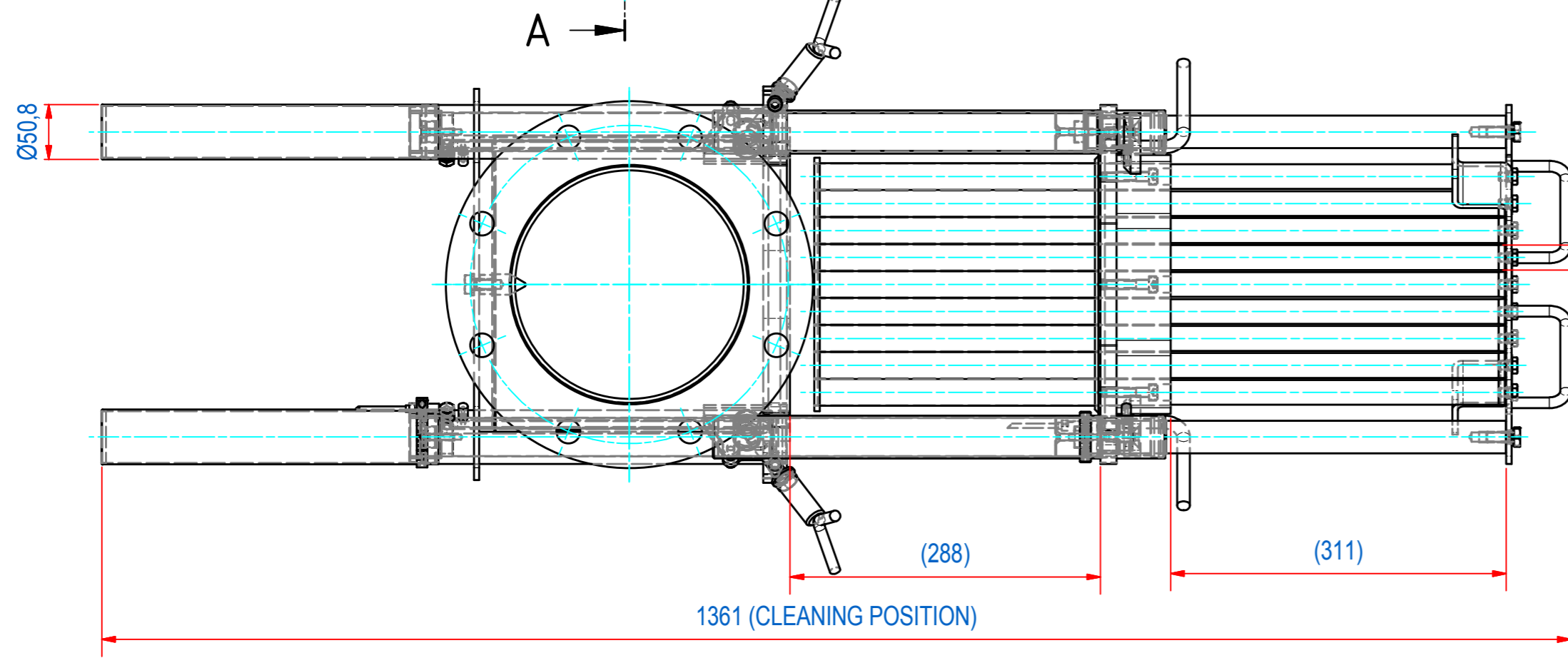
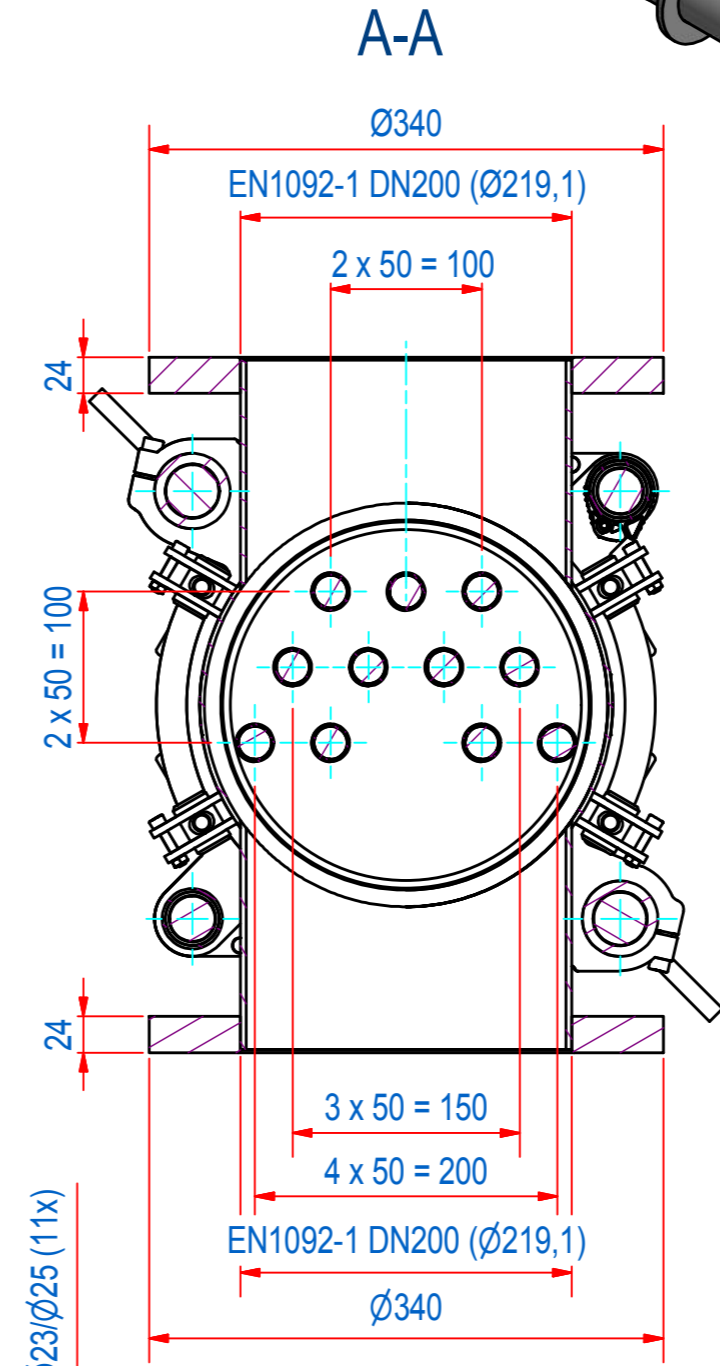
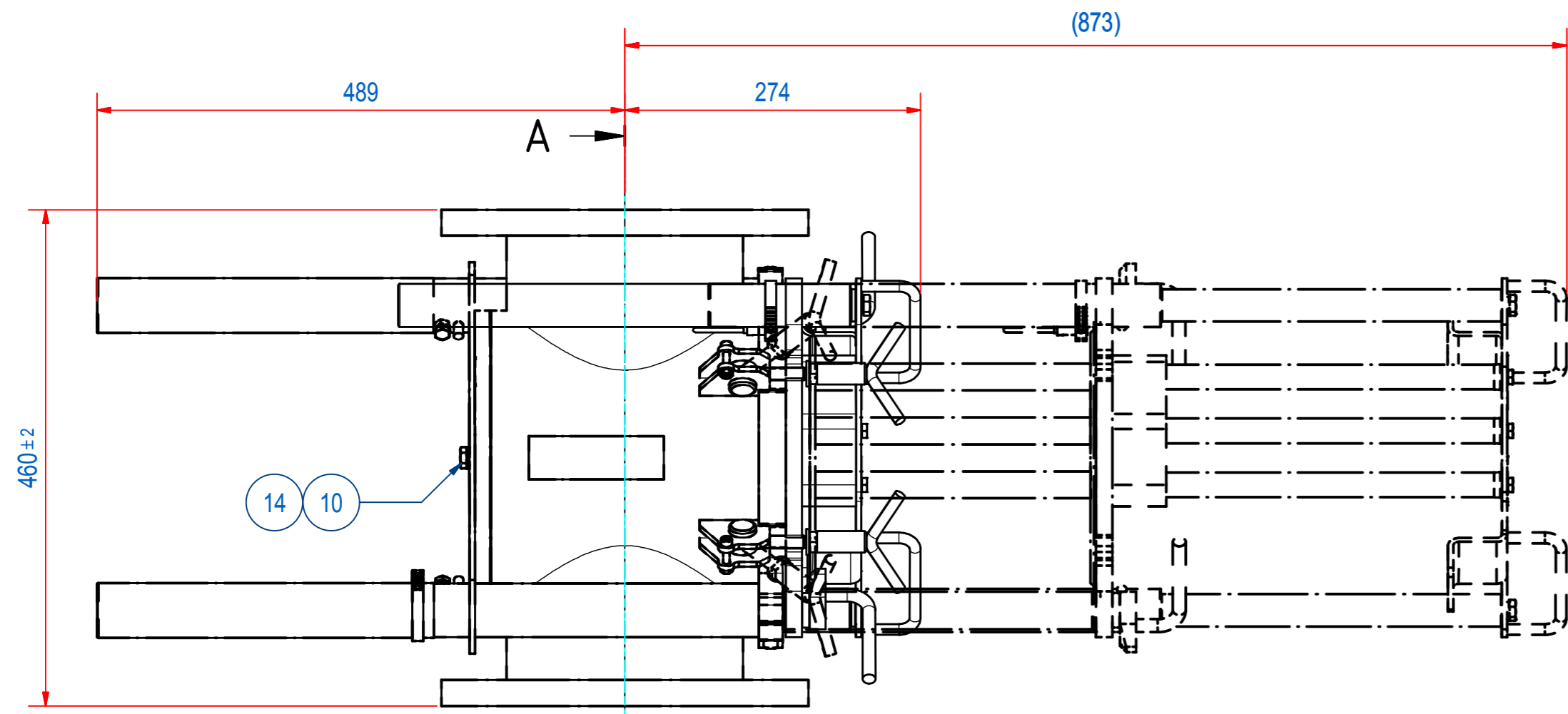
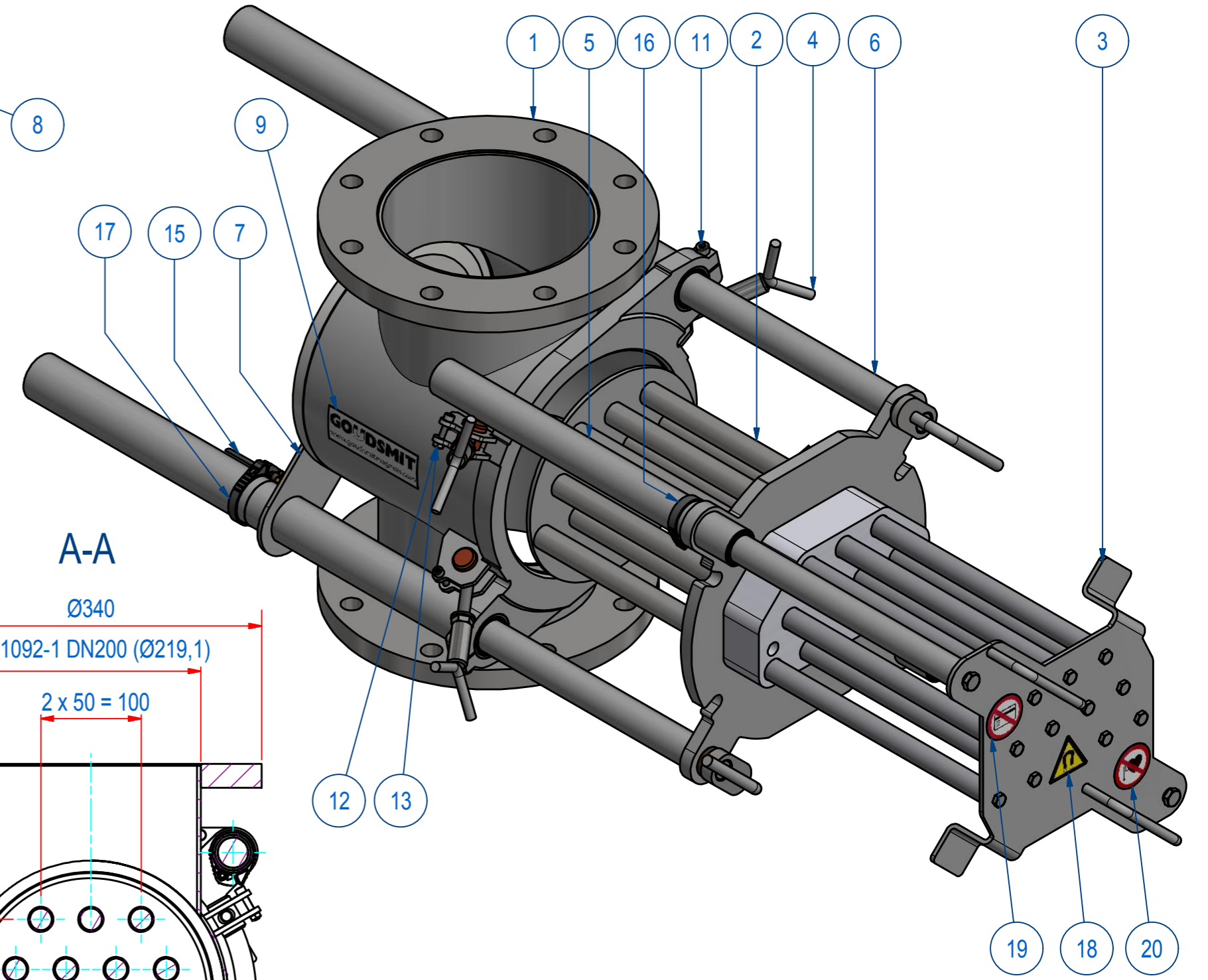
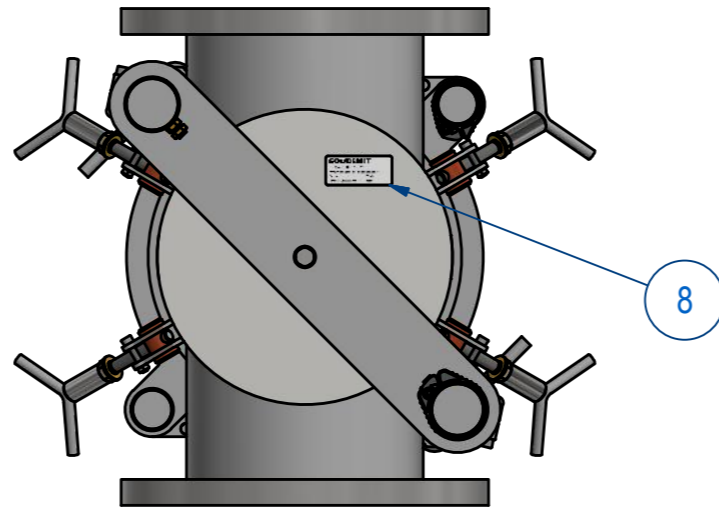
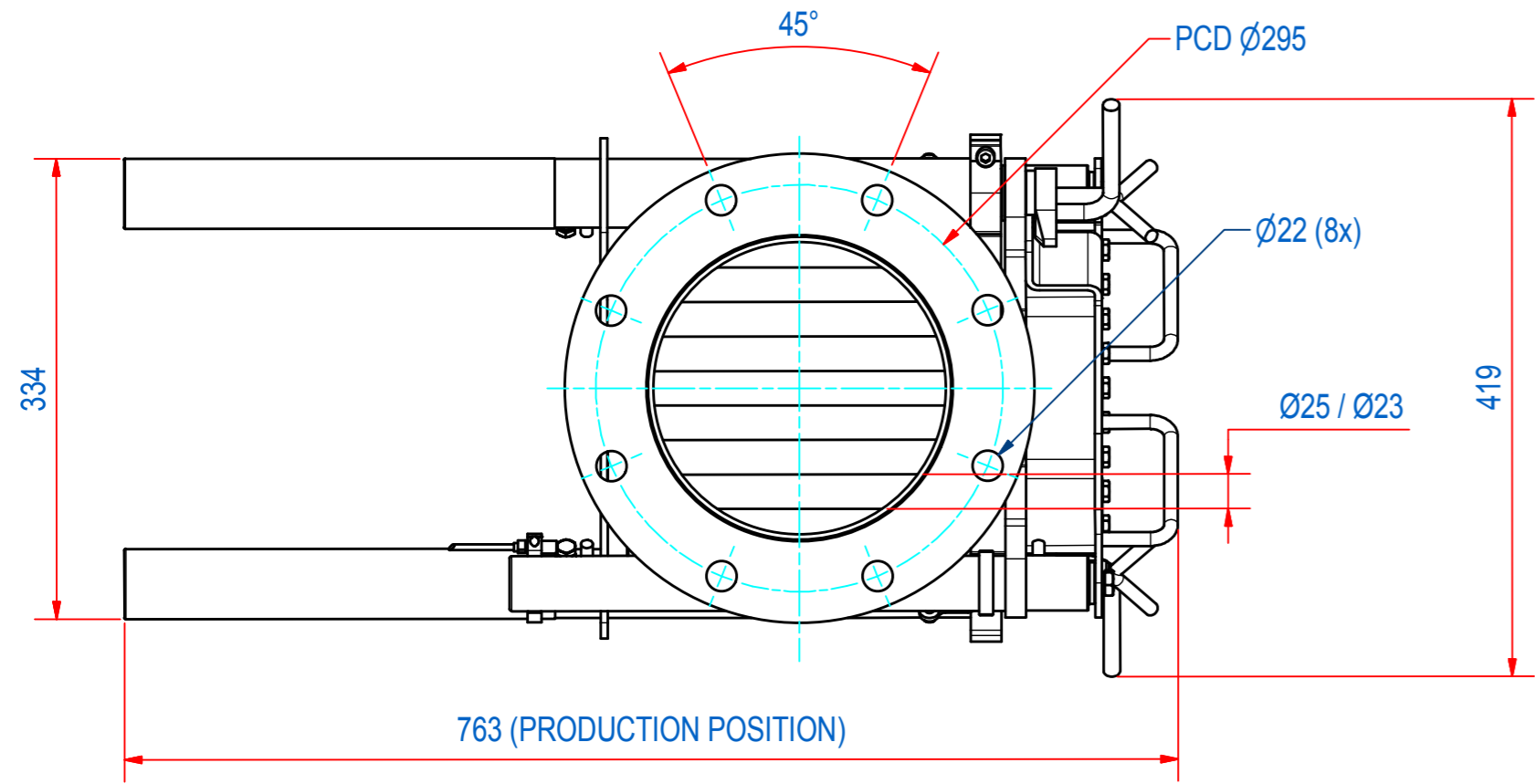

ITEM	QTY	PART NUMBER	DESCRIPTION	Dimensions
20	1	1000.20056	STICK. PACEMAKER FORB. D=50	
19	1	1000.20055	STICKER MAGN. CARD FORB. D=50	
18	1	1000.20030	STICKER MAGNETIC FIELD small	
17	1	83.9900104	MOUNTING PROXY SENSOR CRSMBR-50	
16	1	83.9900105	MOUNTING PROXY SENSOR CRSMBR-40	
15	2	83.9900106	SENSOR CRSMEO-4-K-LED-24	
14	1	70.0200010	WASHER M 10- A2	M 10
13	4	60.0300006	NUT, HEX M6 - A4	M6
12	4	51.0306030	SCREW, HEX SH M6 x 30 - A4	M6 x 30
11	2	51.0208030	SCREW, HEX SH M8 x 30 - A2	M8 x 30
10	1	50.1210020	BOLT, HEX M10x20 - A2	M10x20
9	2	E0103492	NAME PLATE FILTER DN150 D273	
8	1	E0086453	TYPE PLATE FILTER SFN	
7	1	S121415	FS200 SUPPORT STRIP	
6	2	A121062	FS200 GUIDING ROD	
5	2	A121063	FS200 MAGNET PLATE ROD	
4	4	A120739	FS000 TOGGLE M12 + 61	
3	1	A121061	FS200 MAGNET PLATE ASSY	
2	1	A121060	FS200 EXTRACTOR ASSY	
1	1	A121059	FS200 FILTER POT MILLING	

ITEM	QTY	PART NUMBER	DESCRIPTION	Dimensions
RAW MAT.	1			
QTY		MAT. NUMBER	MAT. DESCRIPTION	LENGTH (mm) WIDTH (mm)

Sheet: A2	Extra info:	General tolerance: ISO 2768 - mK
Drawn: AvD	Weight (kg): 96,2	Drawn according: ISO268; ISO1101; ISO2553
Date: 19-7-2013		Status: Standard
Spare part: False		Customer reference number:
Quick search: FSN200	GOUDSMIT MAGNETIC SYSTEMS	File number: SSFNG20038
Description: SFNG-200-IF-11E-HT-F1m-S-B-B	© All rights reserved. Reproduction is not permitted without written permission of GOUDSMIT Magnetic Systems BV	Rev: B
		Part number: SSFNG20038
		Rev: B