

REV	DATE	BY	DESCRIPTION
C	3-5-2013	BS	DRAWING VIEWS CHANGED
D	31-8-2018	CR	ITEM 9 AND 10 ADDED
E	4-12-2018	CR	TYPE PLATE AND WARNING STICKERS ADDED

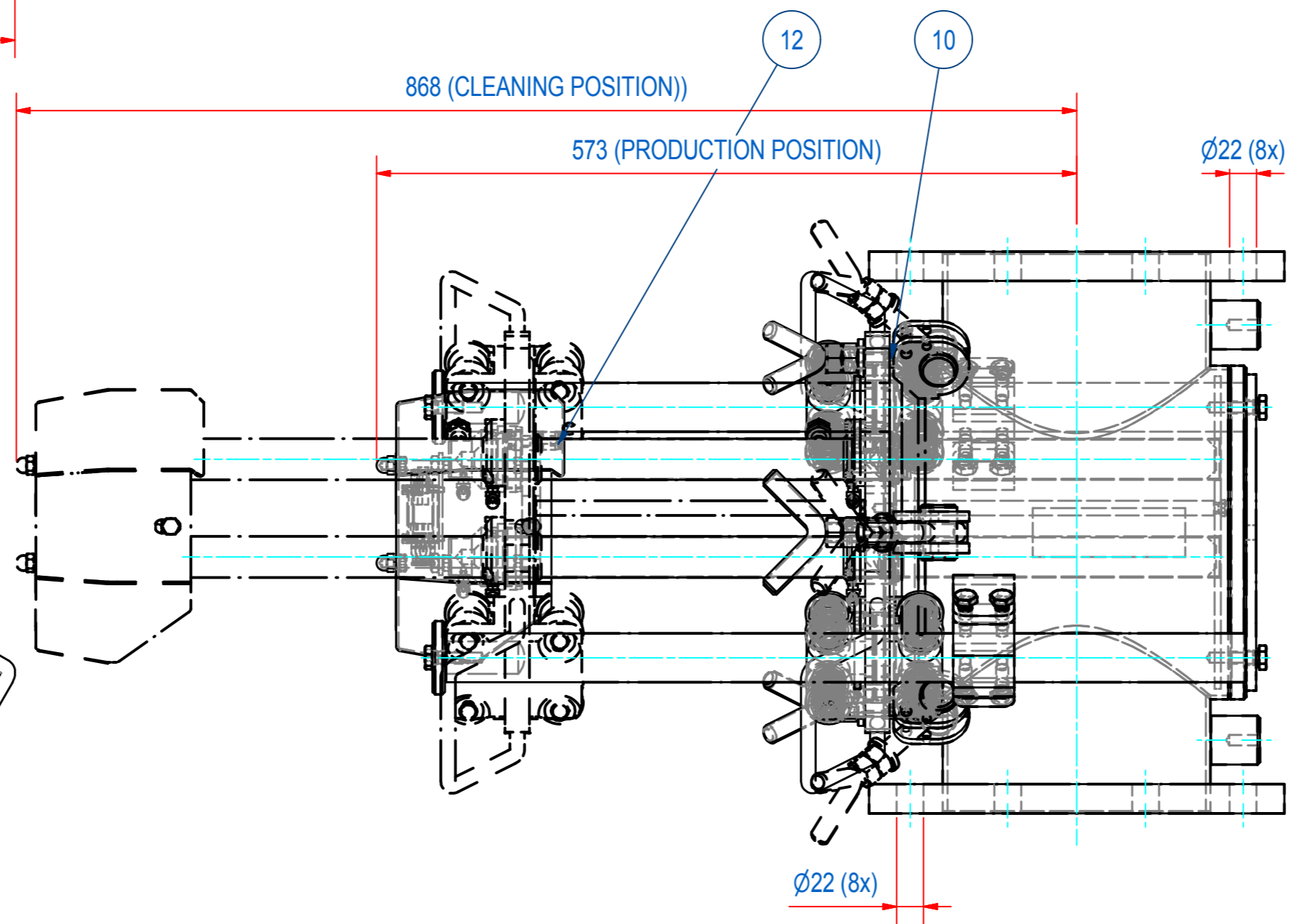
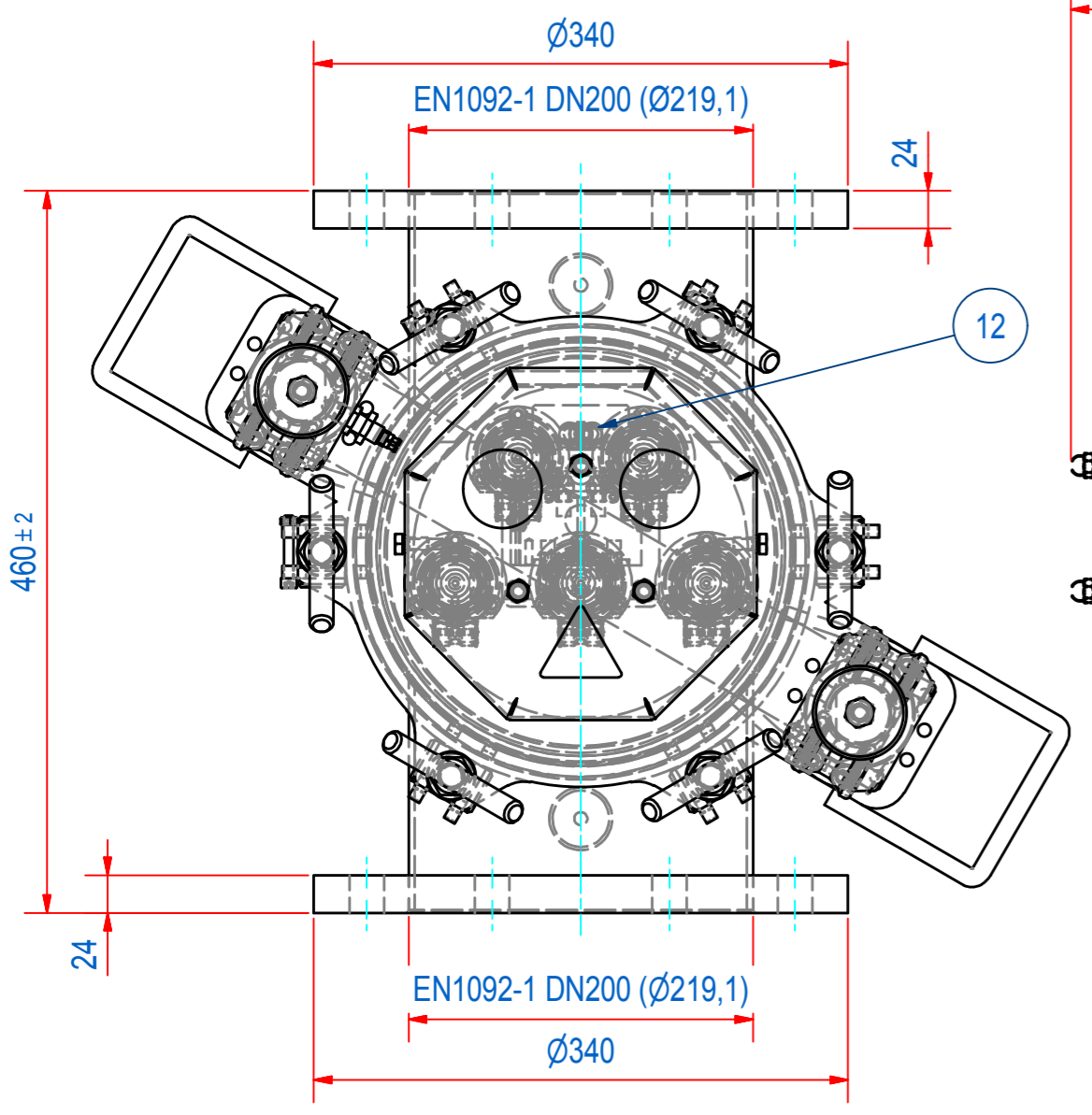
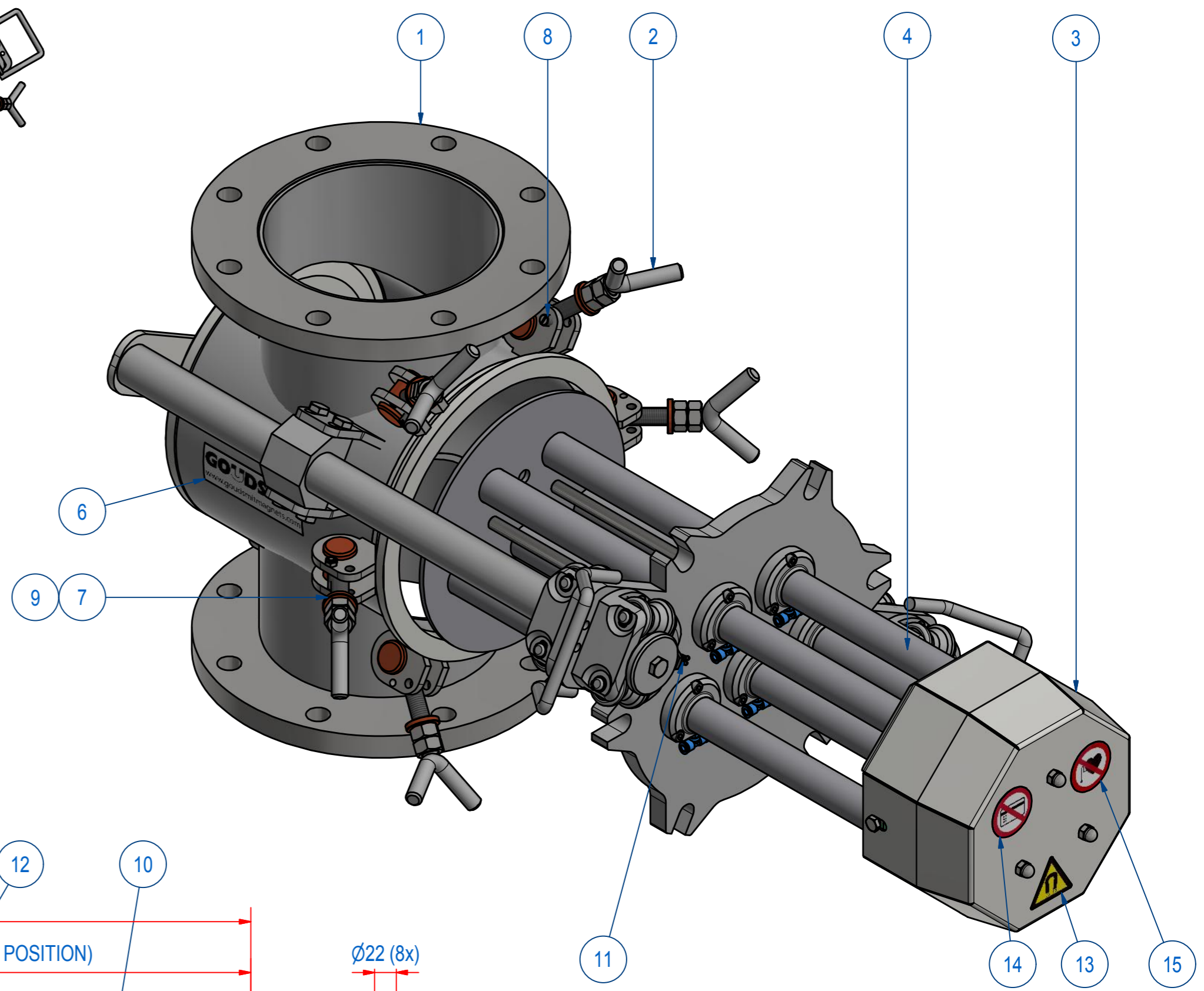
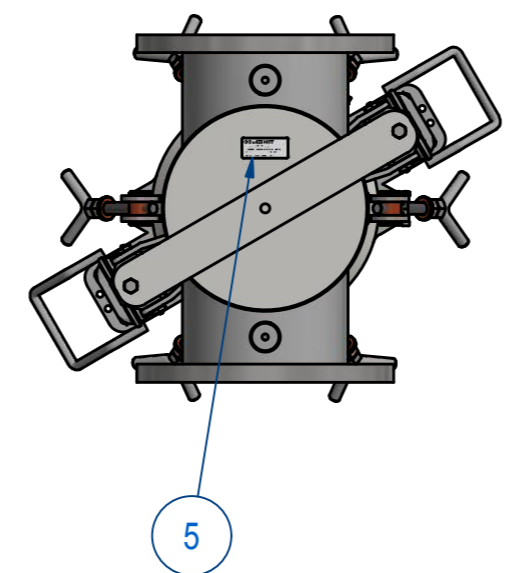
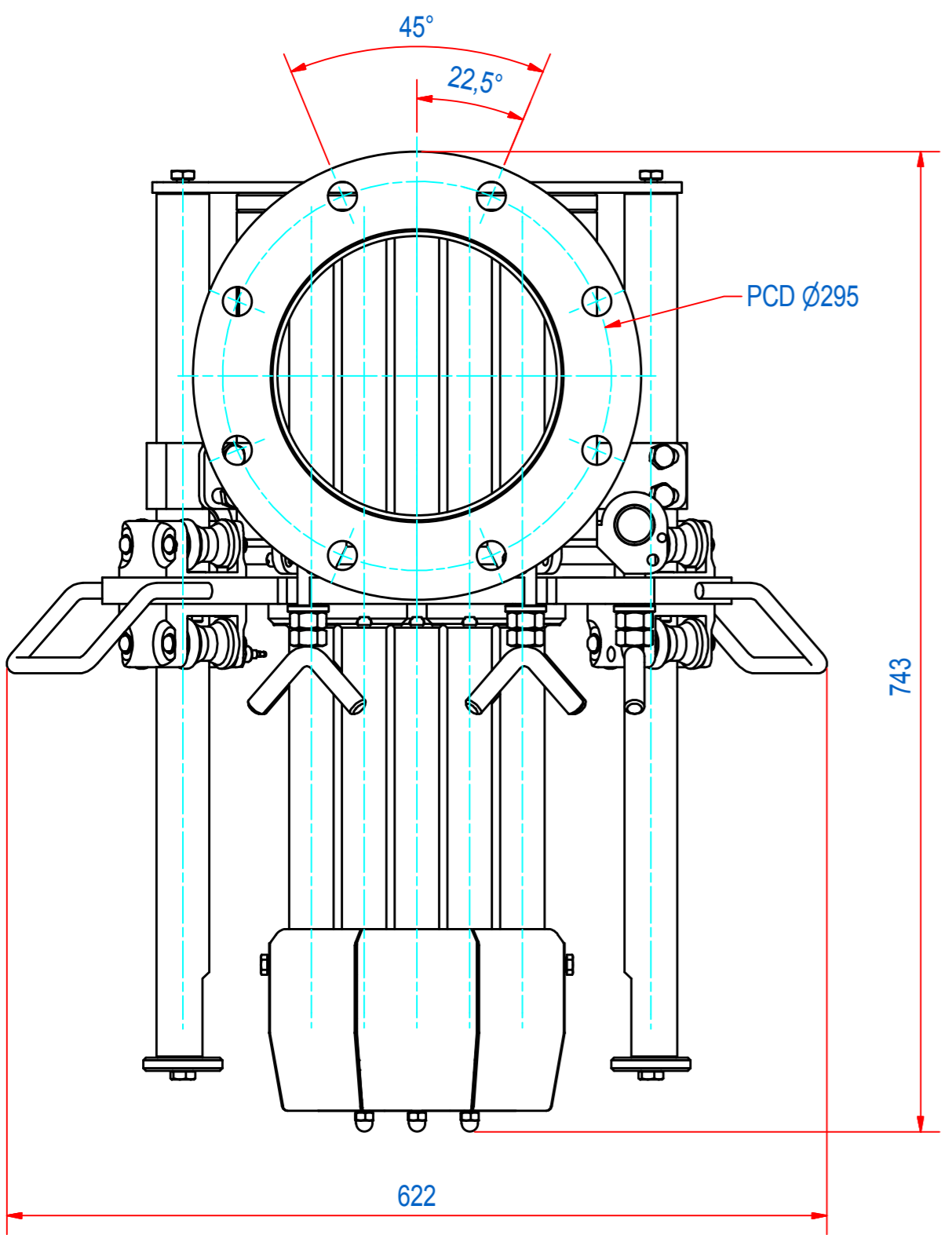

ITEM	QTY	PART NUMBER	DESCRIPTION	Dimensions
15	1	1000.20056	STICK. PACEMAKER FORB. D=50	
14	1	1000.20055	STICKER MAGN. CARD FORB. D=50	
13	1	1000.20030	STICKER MAGNETIC FIELD small	
12	1	83.2570005	PUSH-IN Y-CONNECTOR QSY-8	
11	1	83.1500044	VALVE (SENSOR) 3/2 SVK-3-PK-3	
10	1	78.1272700	O-RING Ø272.4xØ7 EC1935	
9	1	60.0200006	NUT, HEX M6 - A2	M6
8	2	59.0000008	SLOT. SPRING PLUNGER M10X19 SS	
7	1	51.0206040	SCREW, HEX SH M6 x 40 - A2	M6 x 40
6	1	E0103492	NAME PLATE FILTER DN150 D273	
5	1	E0086453	TYPE PLATE FILTER SFN	
4	2	A120653	ALIGNMENT ROD D40	
3	1	A120649	FS200 TOP PNEU D34 ASSY WHEELS	
2	6	A120504	FS000 TOGGLE SET M16	
1	1	A120647	FILTER HOUSE EN1092-1 DN200	

RAW MAT.	QTY	MAT. NUMBER	MAT. DESCRIPTION	LENGTH (mm)	WIDTH (mm)
1	1				

Sheet: A2	Extra info:	General tolerance: ISO 2768 - mK
Drawn: TD	Weight (kg): 101,7	Drawn according: ISO268; ISO1101; ISO2553
Date: 8-4-2013		Status: Standard
Spare part: False		Customer reference number:
Quick search: FP200		File number: SSFNP20038
Description: SFN-200-IF-05Q-HT-F1M-S-B-B		Part number: SSFNP20038