

REV	BY	DATE	DESCRIPTION
-	PH	05.09.2017	REF: SVMF081000, New Vault, change width was 946 now 951mm
-	VZ	05.08.2020	Instalation height sketch added

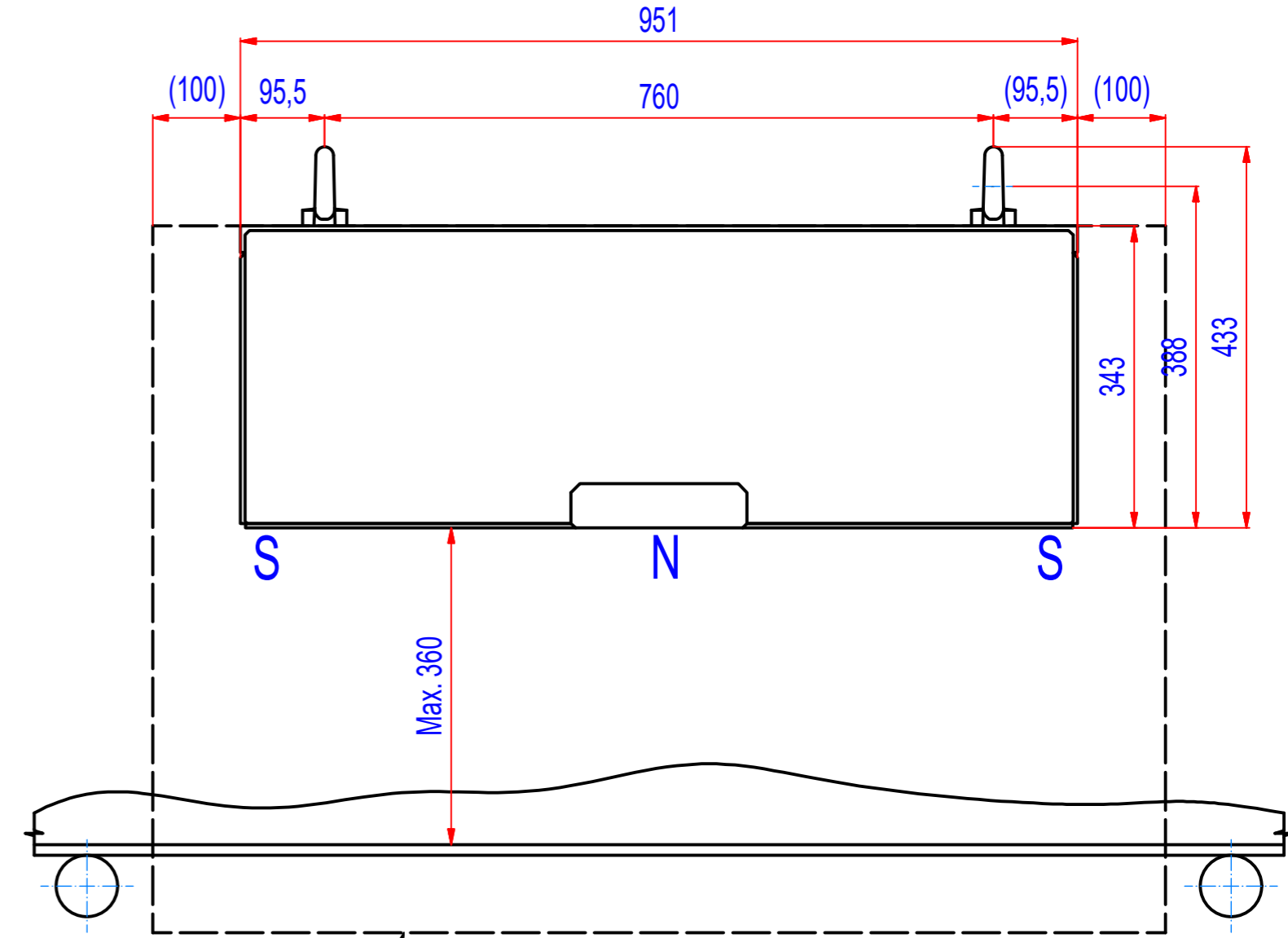

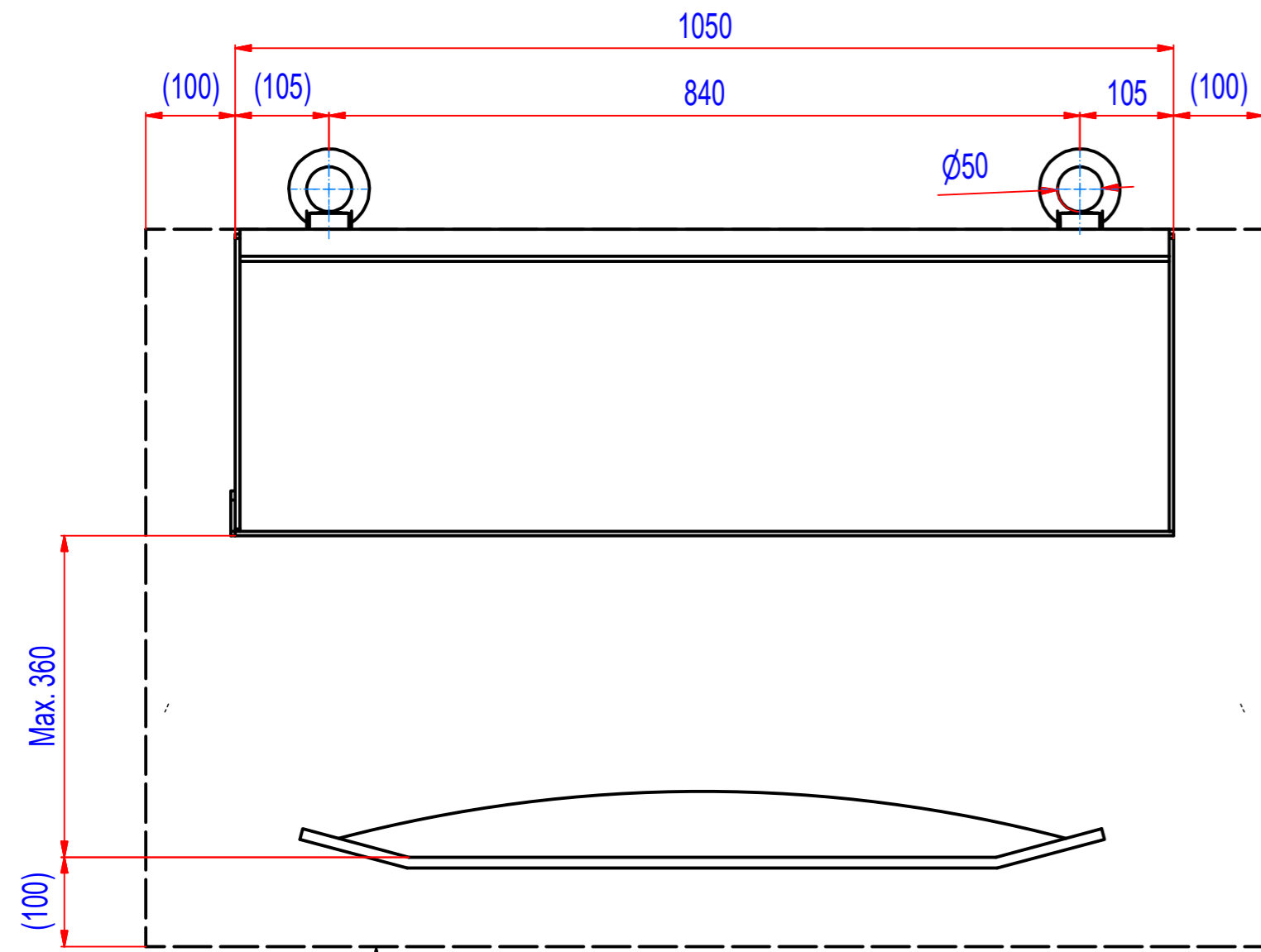
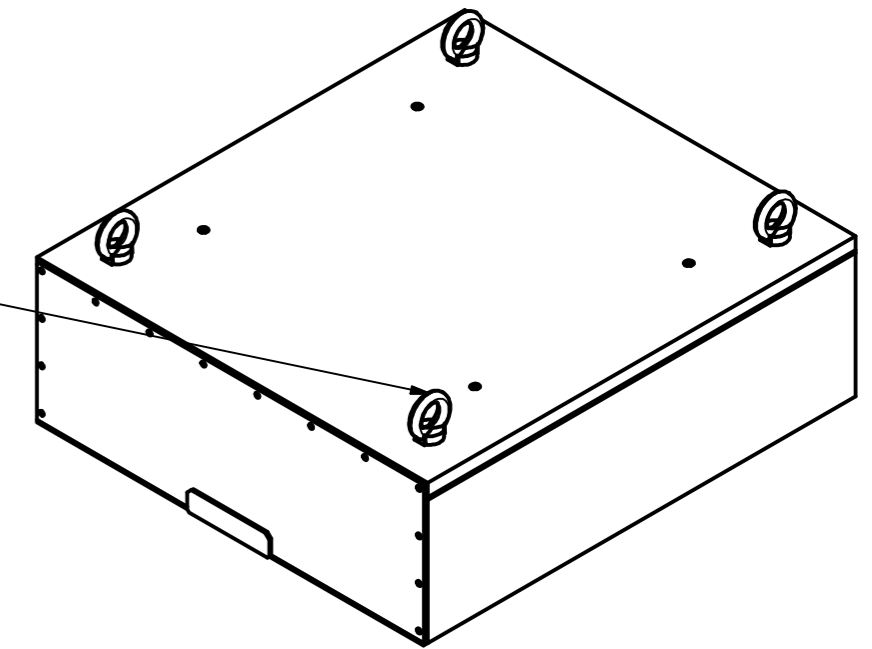

Area of strong effect of magnetic field with influence to Fe separation.  
Magnetic field has an effect also to surrounding structures (supports, frames) and devices.  
We recommend to consult with manufacturer.

4x eye bolt M24 DIN 580

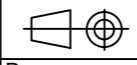

Place warning pictograms near the magnet, see the manual.

1	A254_000000	SVMF081000	1358,2
POZ./POS.	Č. SOUČÁSTI/ PART NUMBER	POPIS / DESCRIPTION	HMOT./ WEIGHT
<b>APPROVAL PLEASE</b>			
Date:	Order ref.:	Responsible person:	
 Sheet: A2 Drawn: PH Date: 05.08.2020 Predecessor:	Weight (kg): 1358,2 Extra info:	General tolerance: ISO 2768 - cL Drawn according: ISO268; ISO1101; ISO2553 Status:	
Quick search: XRBP08 Description: Block magnet permanent, Size 8 L1250, FXD		 <small>© All rights reserved. Reproduction is not permitted without written permission of GOUDSMIT Magnetic Systems BV</small>	
		Customer reference number:	Product key: SVM-F-946x343-1050-F-F0E
		Part number: SVMF081000	Rev: -