

REV	BY	DATE	DESCRIPTION
-	LF	23.09.2018	ORIGINAL DRAWING
-	VZ	05.08.2020	Installation height sketch added

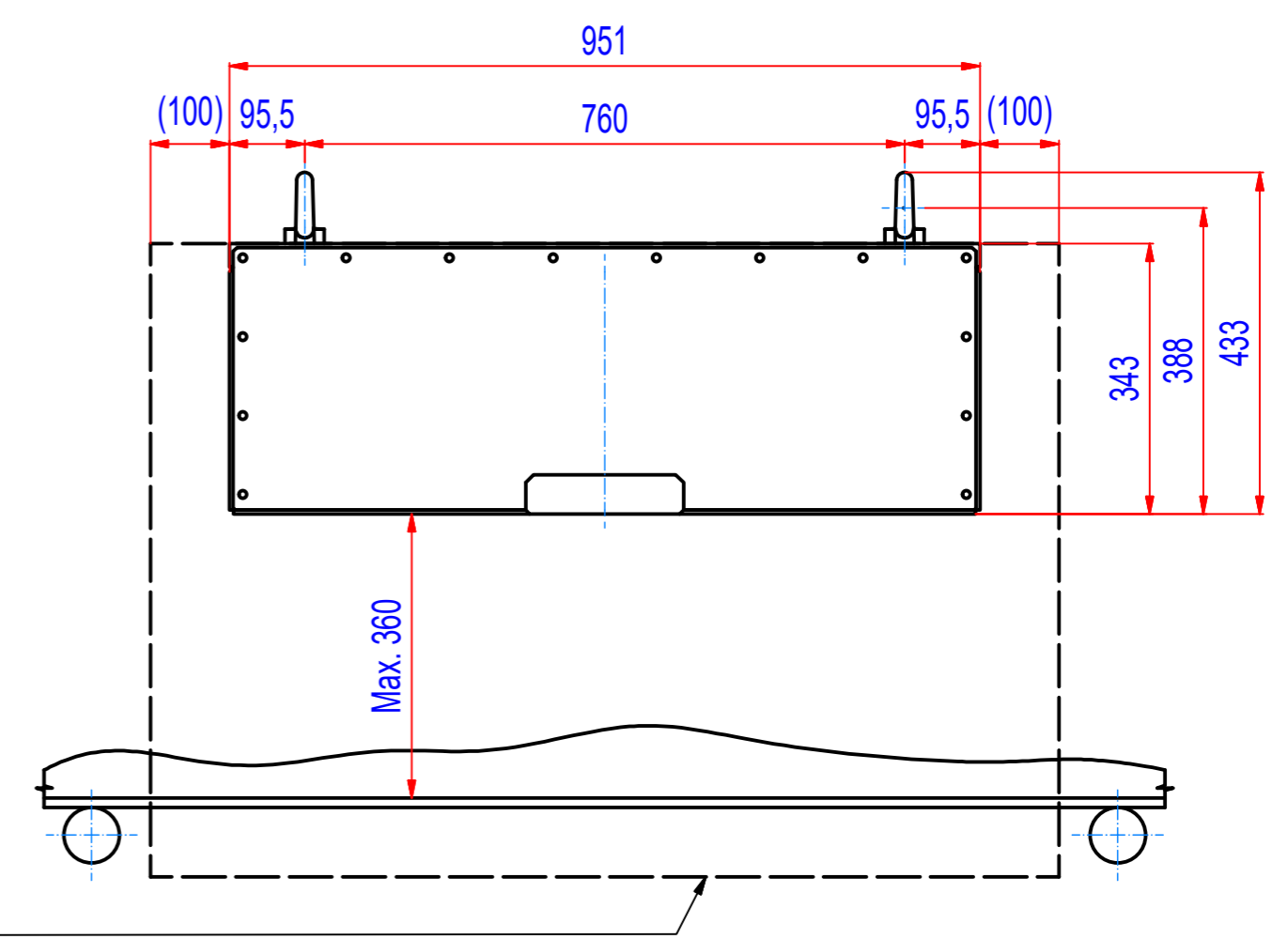

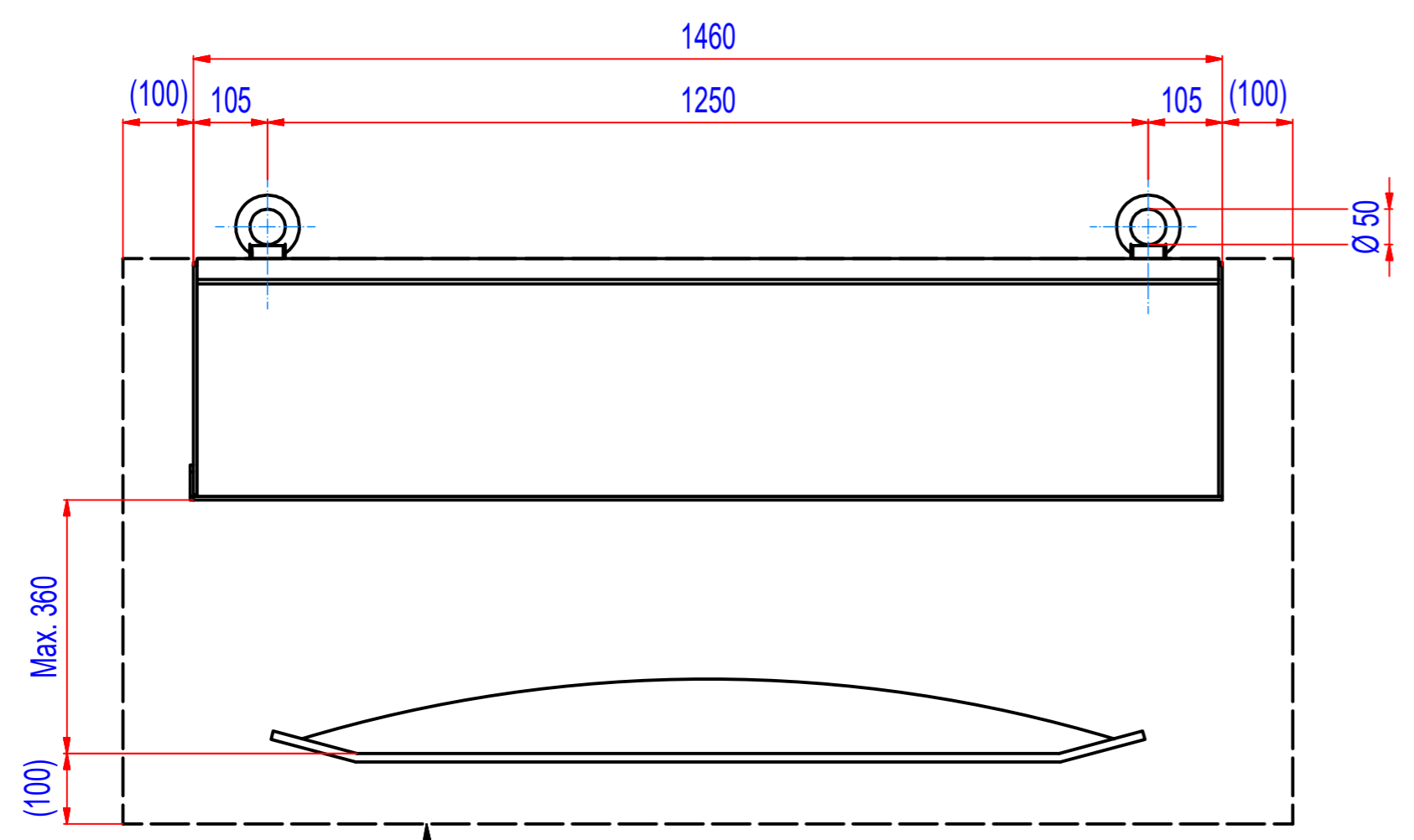

Area of strong effect of magnetic field with influence to Fe separation.
 Magnetic field has an effect also to surrounding structures (supports, frames) and devices.
 We recommend to consult with manufacturer.

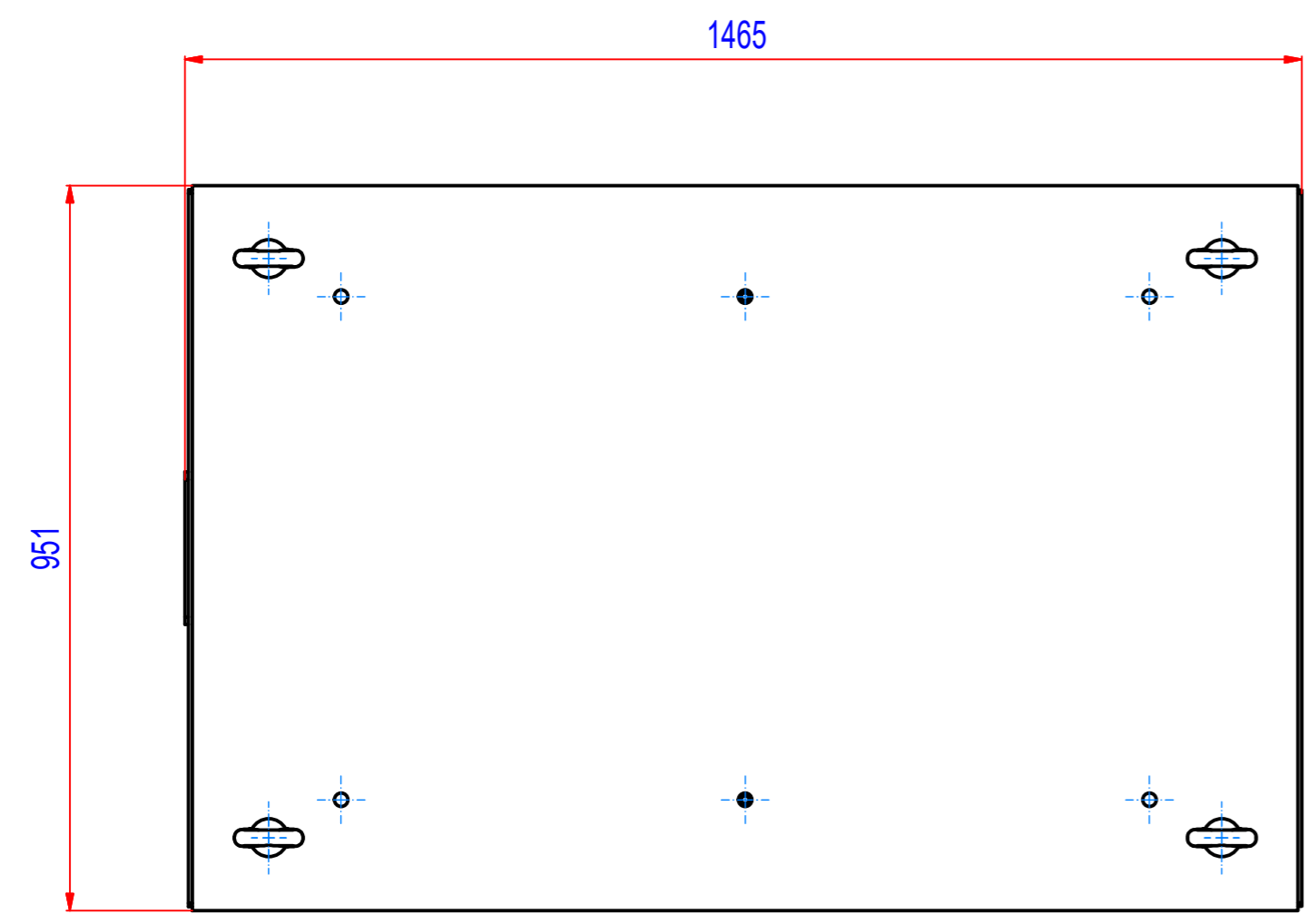

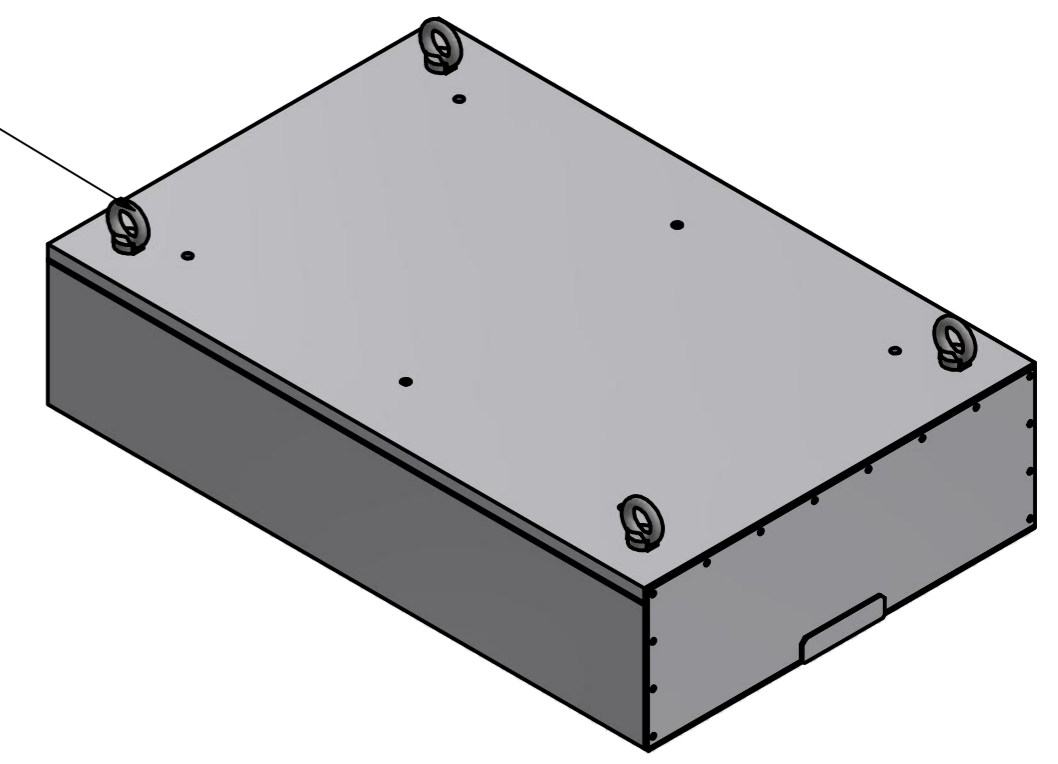
4x eye bolt M24 DIN 580

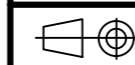

Place warning pictograms near the magnet, see the manual.

APPROVAL PLEASE			
Date:	Order ref.:	Responsible person:	
 Sheet: A2 Drawn: LF Weight (kg): 1924,5 kg Date: 05.08.2020 Predecessor:	Extra info:	General tolerance: ISO 2768 - cL Drawn according: ISO268; ISO1101; ISO2553 Status:	
Quick search: XRBP08	 <small>© All rights reserved. Reproduction is not permitted without written permission of GOUDSMIT Magnetic Systems BV</small>	Customer reference number:	
Description: BLOCK MAGNET PERMANENT, SIZE 8, L=1675, FXD		Product key: SVM-F-951x343-1460-F-F0E Part number: SVMF081400 Rev: -	