

REV	DATE	BY	DESCRIPTION
-	1-4-2014	CR	NEW REVISION VAULT, NOTHING CHANGED, OLD REV WAS B
A	30-6-2015	CR	GASKET CHANGED: COMPOUND 714206 WAS COMPOUND 714166
B	8-10-2018	CR	ITEM 6, 11, 12 AND 13 (TYPE PLATE AND WARNING STICKERS) ADDED, ITEM 9 CHANGED INTO WASHER M10 3xD

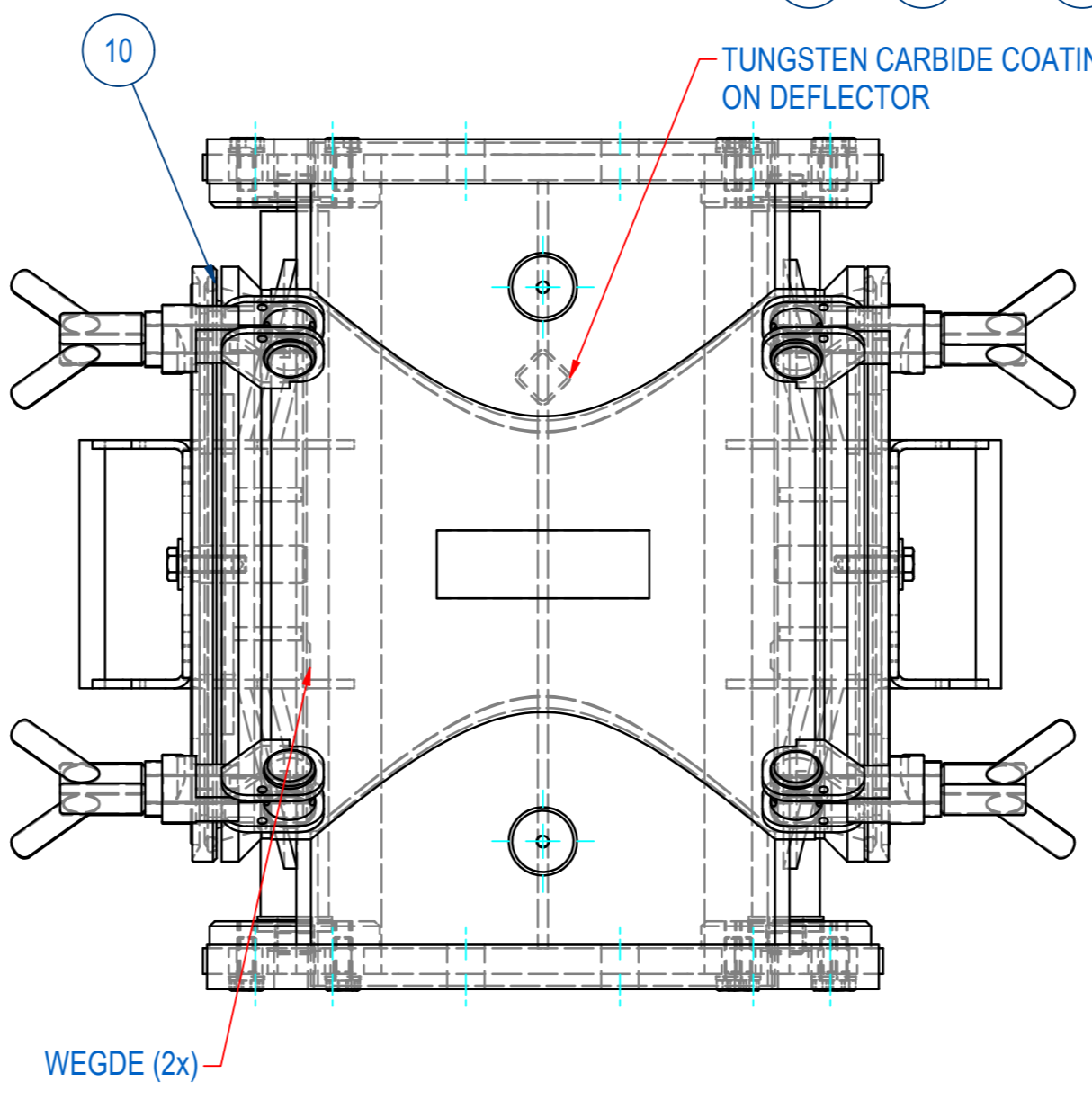
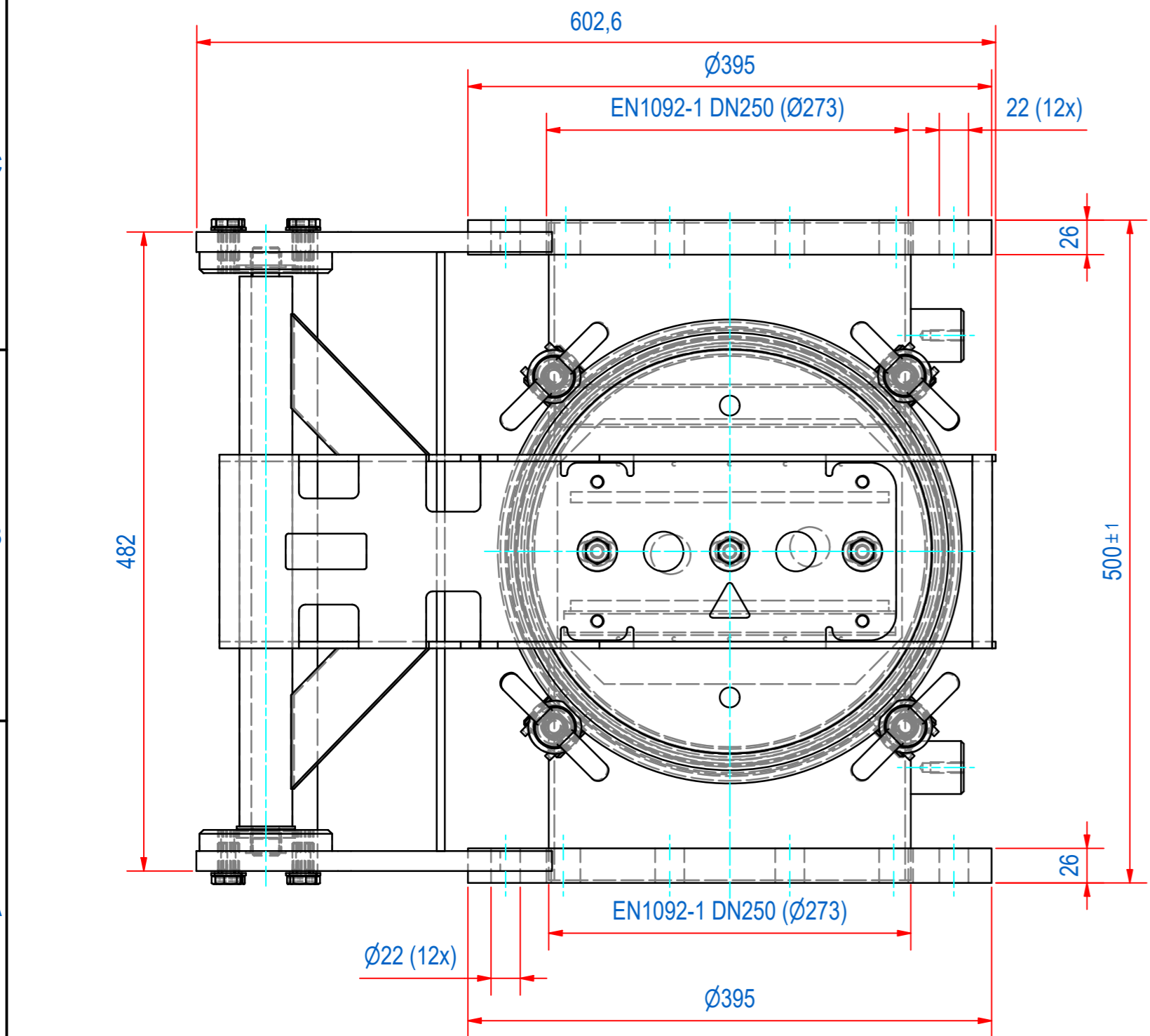
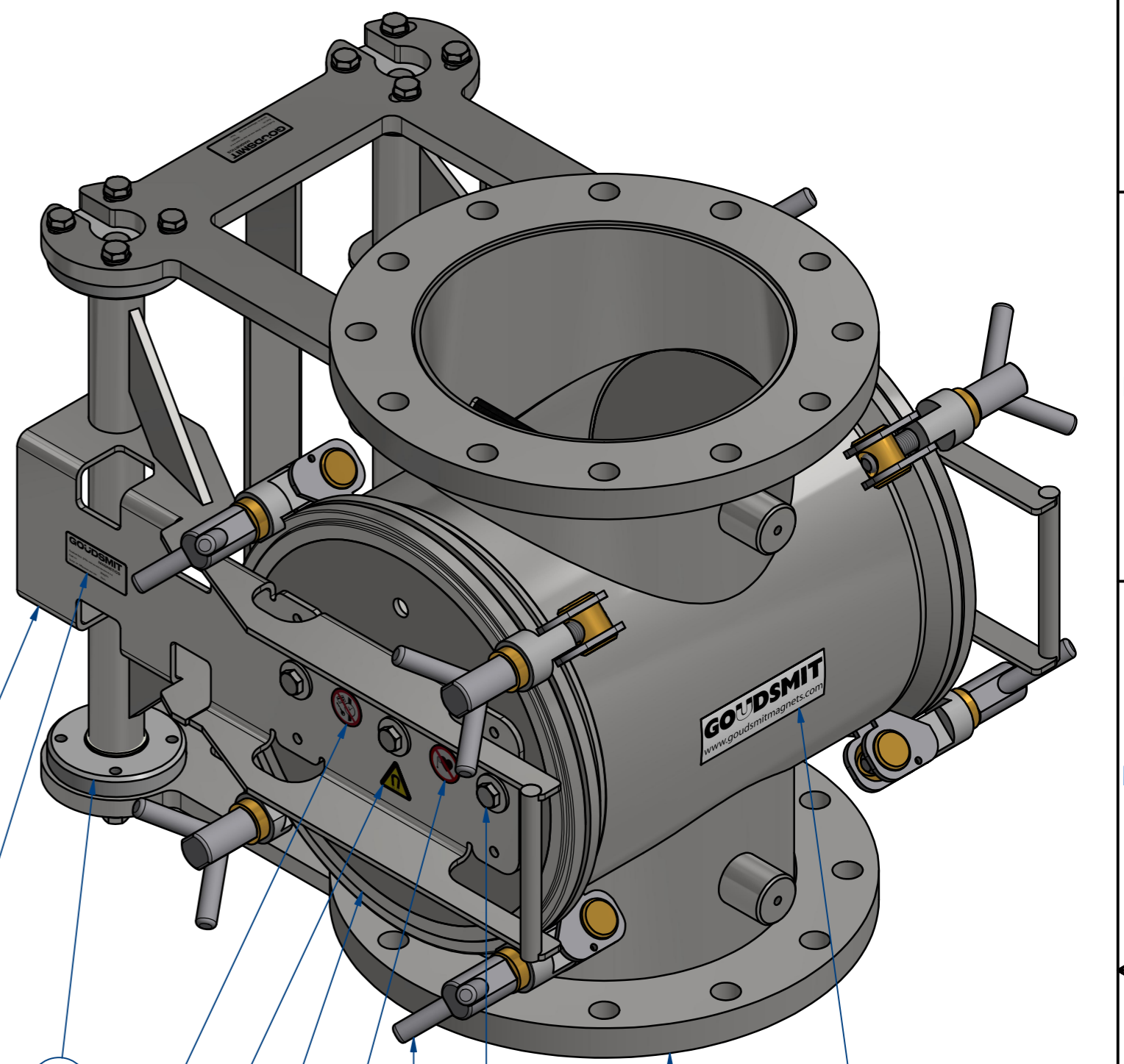
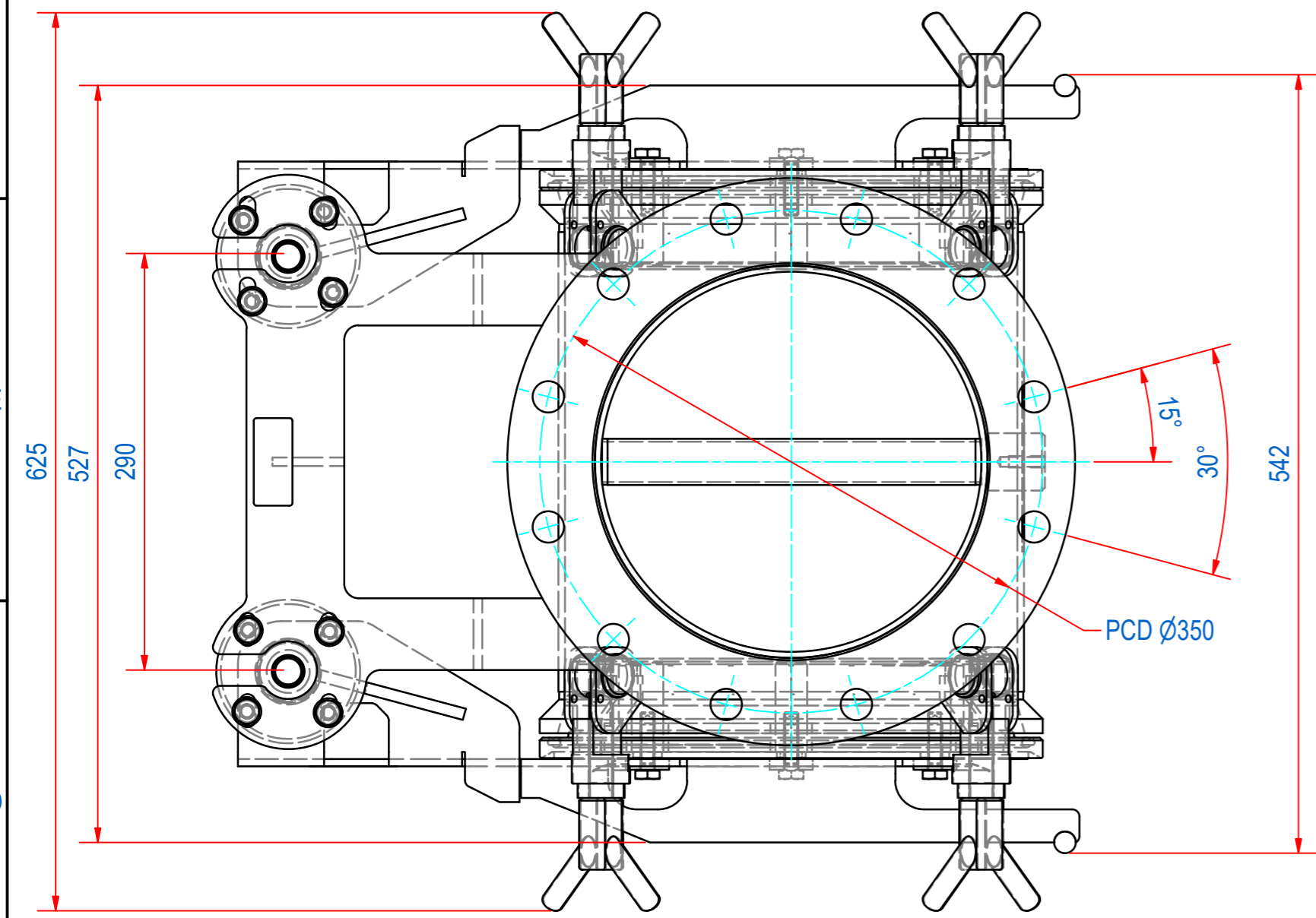

- 3
- 6
- 4
- 11
- 13
- 2
- 12
- 5
- 8
- 9
- 1
- 7

ITEM	QTY	PART NUMBER	DESCRIPTION	Dimensions
13	2	1000.20027	STICKER MAGNETIC FIELD 30mm	
12	2	1000.20020	STICKER PACEMAKER FORBID. D=30	
11	2	1000.20019	STICKER ARTICLES FORBID D30	
10	2	78.1320690	O-RING Ø320x6,99 SILICONE EC1935	
9	6	70.9200004	WASHER 3xd M10x30 - A2	M10x30
8	6	50.1210040	BOLT, HEX M10x40 - A2	M10x40
7	1	E0103017	NAME PLATE GOUDSMIT SFN250	
6	3	E0086453	TYPE PLATE FILTER SFN	
5	8	M58577	GPFF-000 QUICK CLAMP ASSY	
4	2	M66613	GPFF-000 BEARINGS [SET] D20	
3	2	M80148	HINGE DN250 304L	
2	2	M80139	FILTER MAGNET DN250 NdFeB	
1	1	M87009	BODY DN250 HINGE WELDING	

RAW MAT. Quantity: 1	Material Number	Material Description	Length (mm)	Width (mm)
Sheet: A2	Extra info:	General tolerance: ISO 2768 - mK		
Drawn: CR	Weight (kg): 140	Drawn according: ISO268; ISO1101; ISO2553		
Date: 1-4-2014	Source:	Status: Standard		
Spare part: False	Quick search: SFN250	Customer reference number:		
Description: SFN-250-IF-020-N-F1m-S-B-B-B	Document number: SFZN001160	Doc.Rev: B		
	Part number: SFZN001160	Rev: B		