

REV	DATE	BY	DESCRIPTION
-	12-2-2014	PB	NEW VAULT NEW REVISION. OLD REV WAS B
A	8-6-2022	PB	WELD ASSY ADDED
B	25-1-2023	DK	SOURCE CODE AND TYPE STICKER ADDED

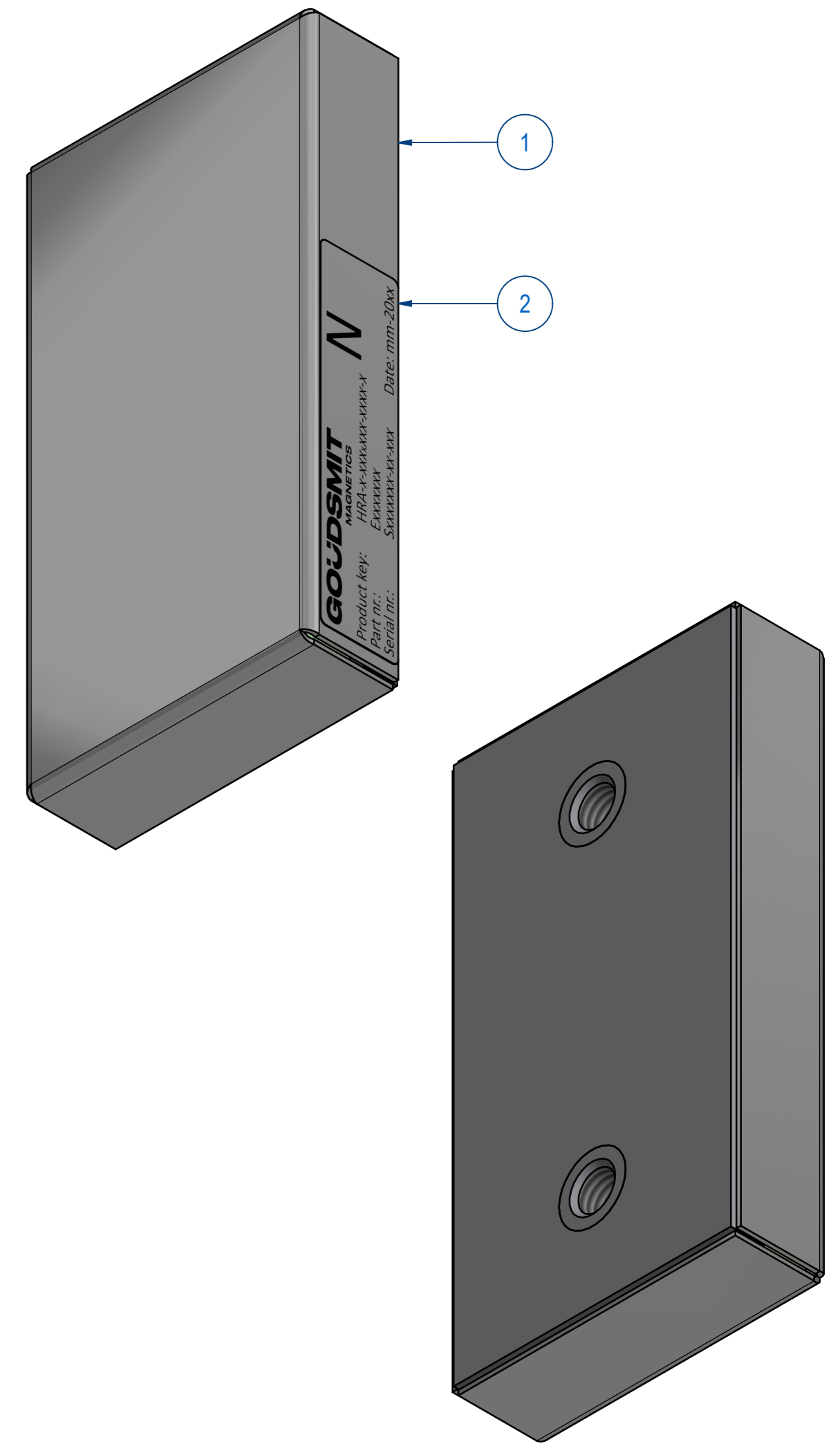
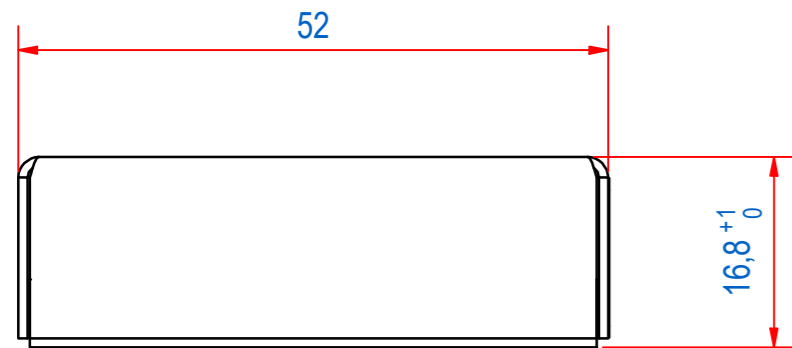
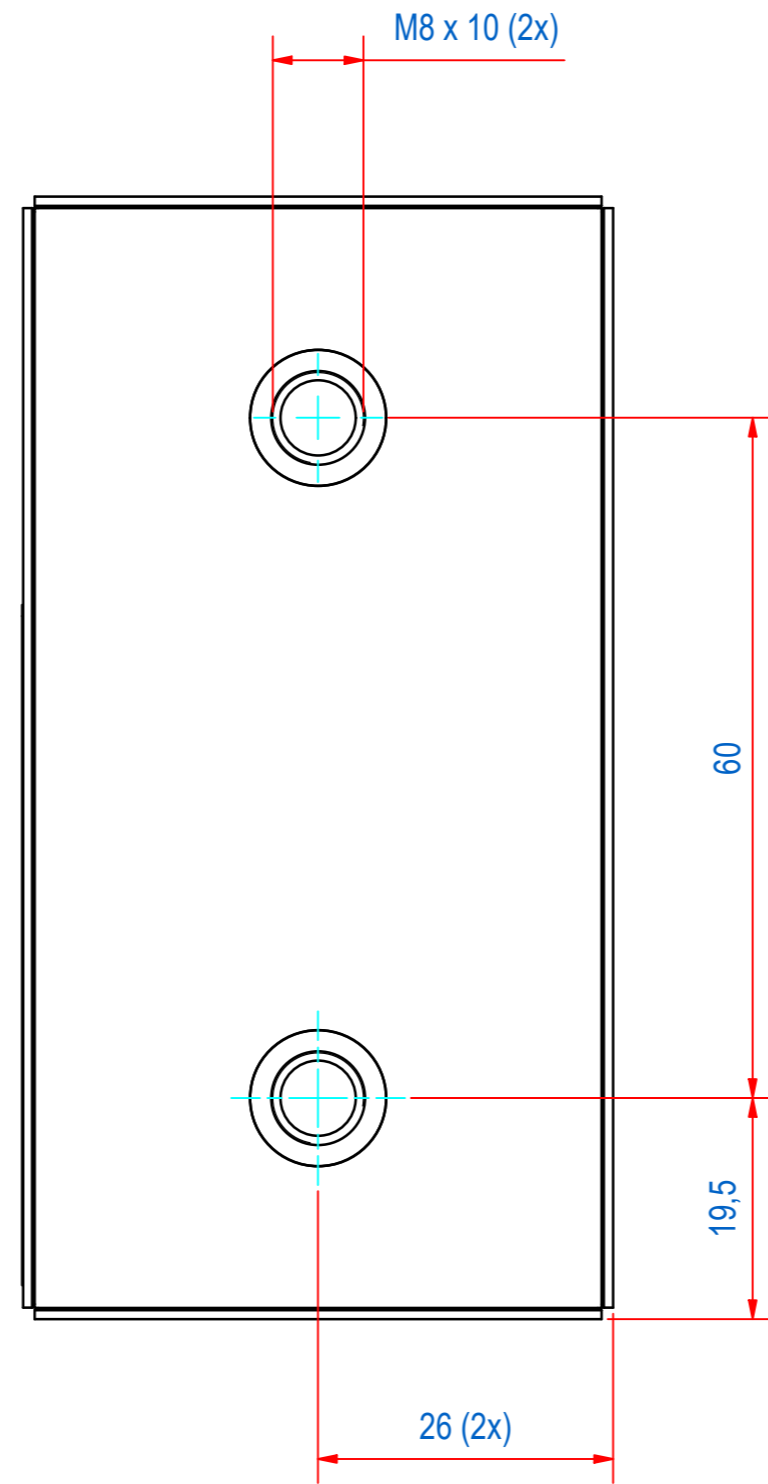
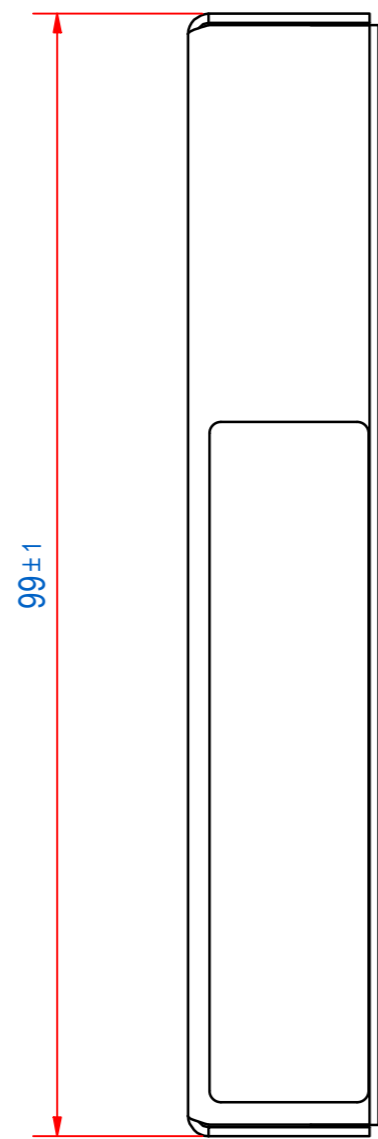
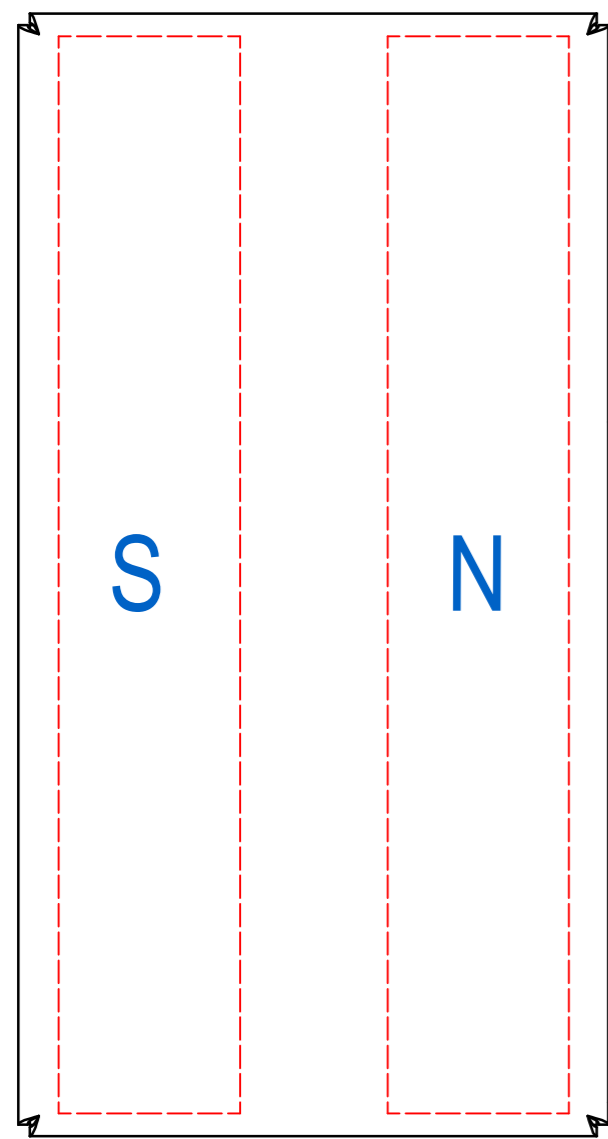

ITEM	QTY	PART NUMBER	DESCRIPTION	Dimensions
2	1	E0156615	HRA-TYPE PLATE STICKER	
1	1	E0153113	HRA-WELD ASSY	
RAW MAT.	Quantity	Material Number	Material Description	Length (mm) Width (mm)
	1			
Sheet: A2		Extra info: MAGNETIC RAIL		General tolerance: ISO 2768 - mK
Drawn: PB		Weight (kg): 0,44		Drawn according: ISO268; ISO1101; ISO2553
Date: 12-2-2014		Source: MC-C		Status: Standard
Spare part: False		Quick search: TBAA01		Customer reference number:
Description: HRA-F-052x17-AA-0100-B-B		© All rights reserved. Reproduction is not permitted without written permission of GOUDSMIT Magnetic Systems BV		Document number: TBAA010001 Doc.Rev: B
		Part number: TBAA010001		Rev: B