

REV	DATE	BY	DESCRIPTION
-	21-5-2014	BS	NEW VAULT, NOTHING CHANGED, IS EQUAL TO OLD REVISION A
A	11-7-2022	PB	WELD ASSY ADDED
B	4-1-2023	DK	SOURCE CODE ADDED, TYPE STICKER ADDED

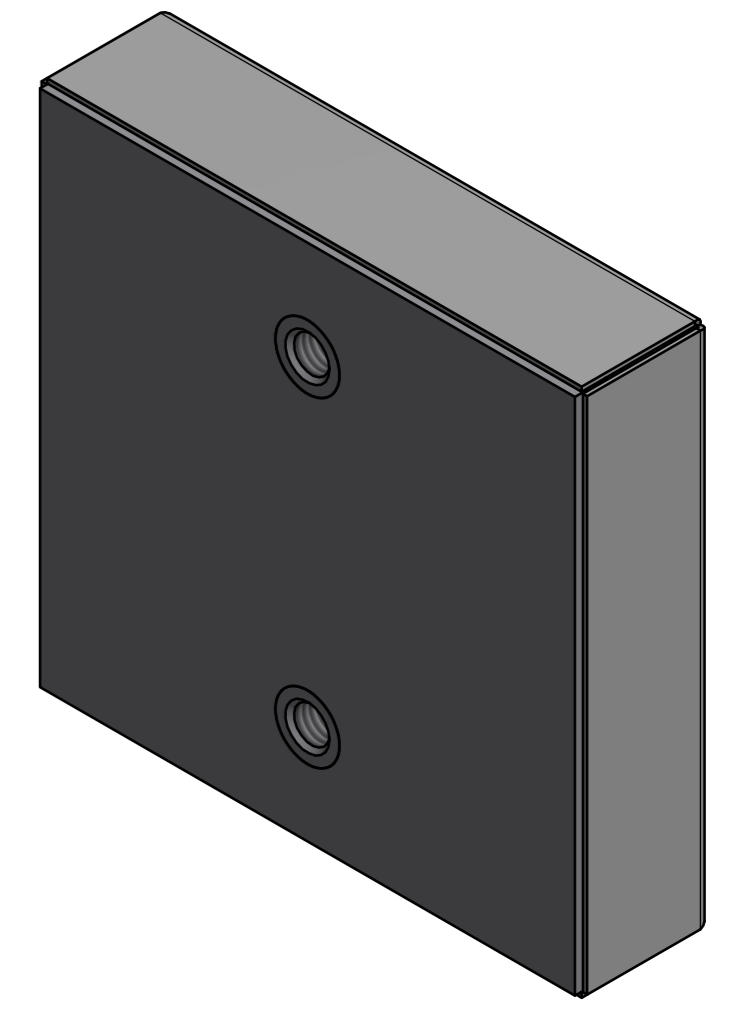
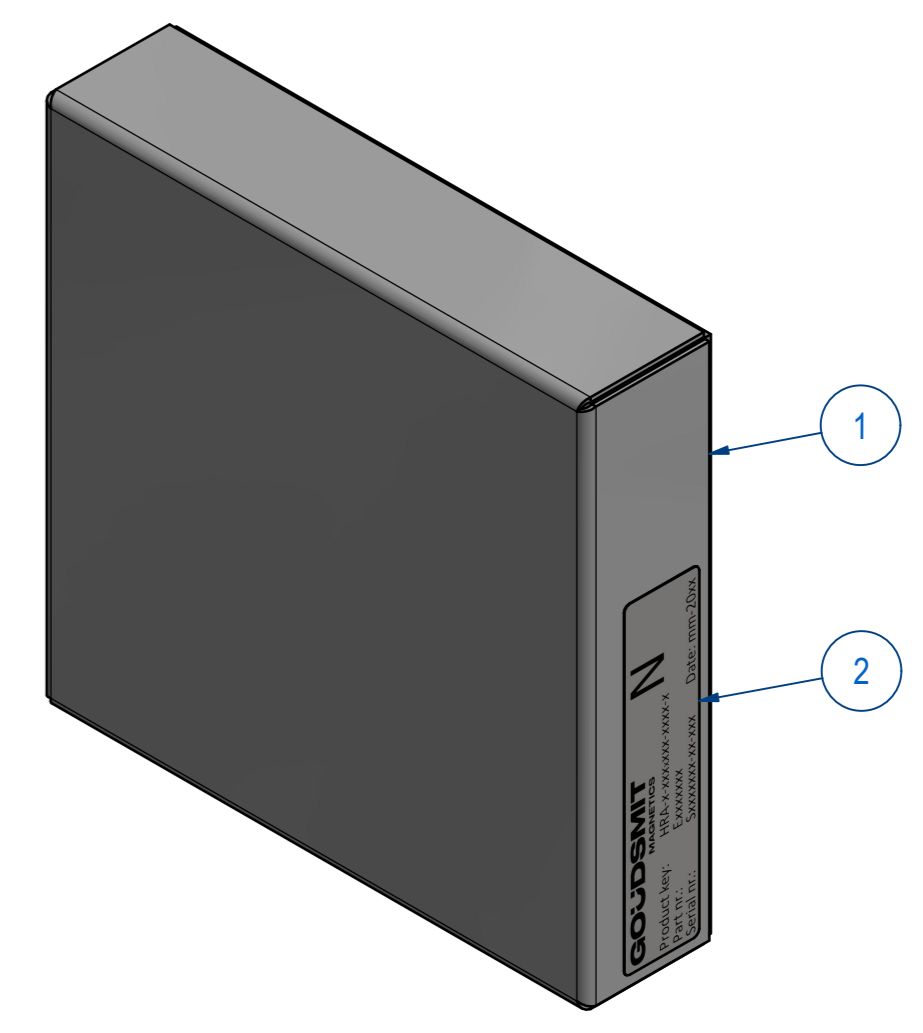
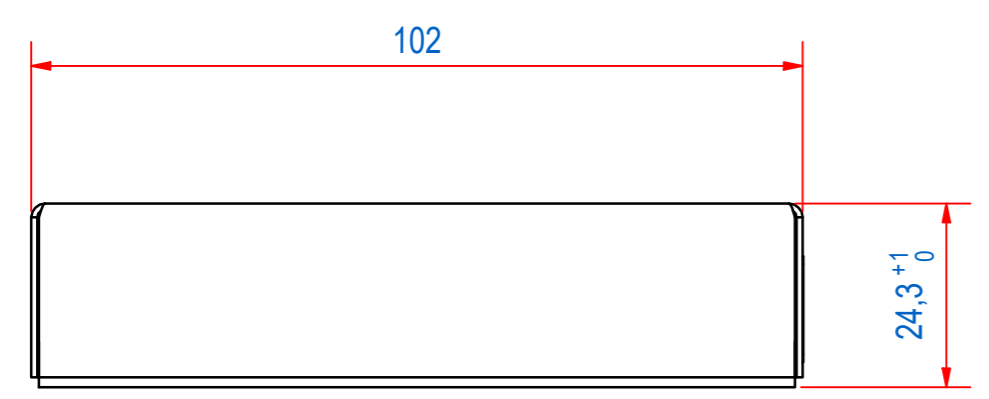
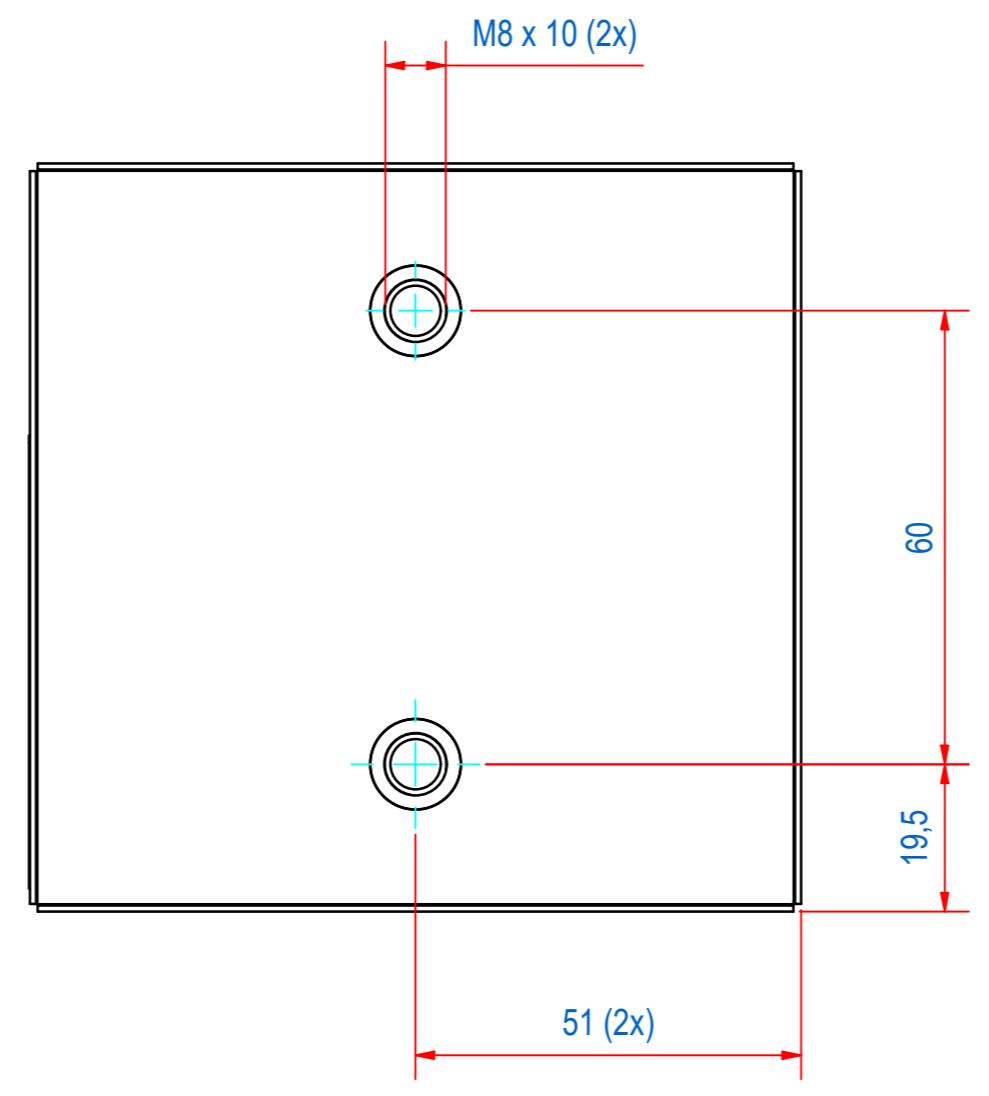
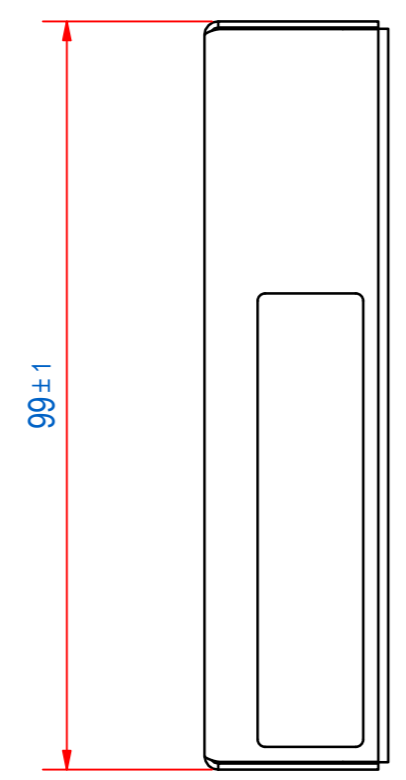
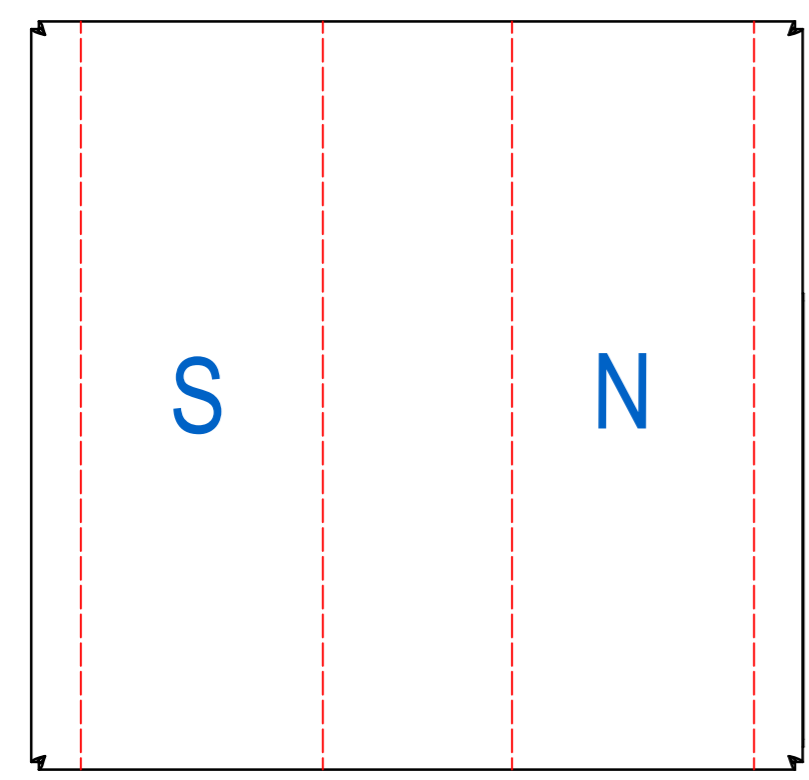

ITEM	QTY	PART NUMBER	DESCRIPTION	Dimensions
2	1	E0156615	HRA-TYPE PLATE STICKER	
1	1	E0153756	HRA-WELD ASSY	
RAW MAT.	1			
Quantity	Material Number		Material Description	Length (mm) Width (mm)
Sheet:	A2		Extra info: MAGNETIC RAIL	General tolerance: ISO 2768- mK
Drawn:	BS		Weight (kg): 1,1	Drawn according: ISO268; ISO1101; ISO2553
Date:	21-5-2014			Status: Standard
Spare part:	False		Source: MC-C	Customer reference number:
Quick search:	TBAA03		 <small>© All rights reserved. Reproduction is not permitted without written permission of GOUDSMIT Magnetic Systems BV</small>	Document number: TBAA010003 Doc.Rev: B
Description:	HRA-F-102x24-AA-0100-B-B			Part number: TBAA010003 Rev: B