

| REV | DATE | BY | DESCRIPTION |
|-----|----------|----|---|
| - | 2-4-2014 | PB | NEW VAULT, NEW REVISION. NOTHING CHANGED. OLD REV WAS A |
| A | 4-1-2023 | DK | SOURCE CODE ADDED, TYPE PLATE STICKER ADDED |

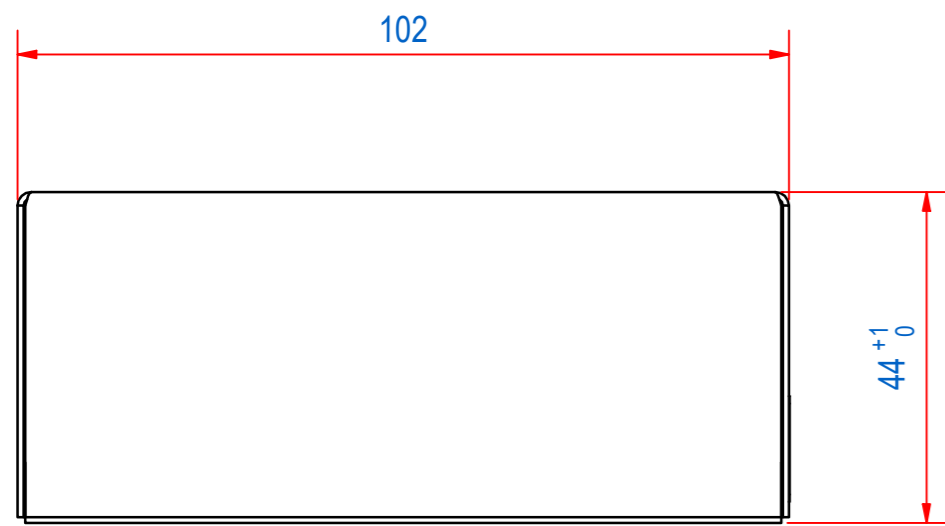
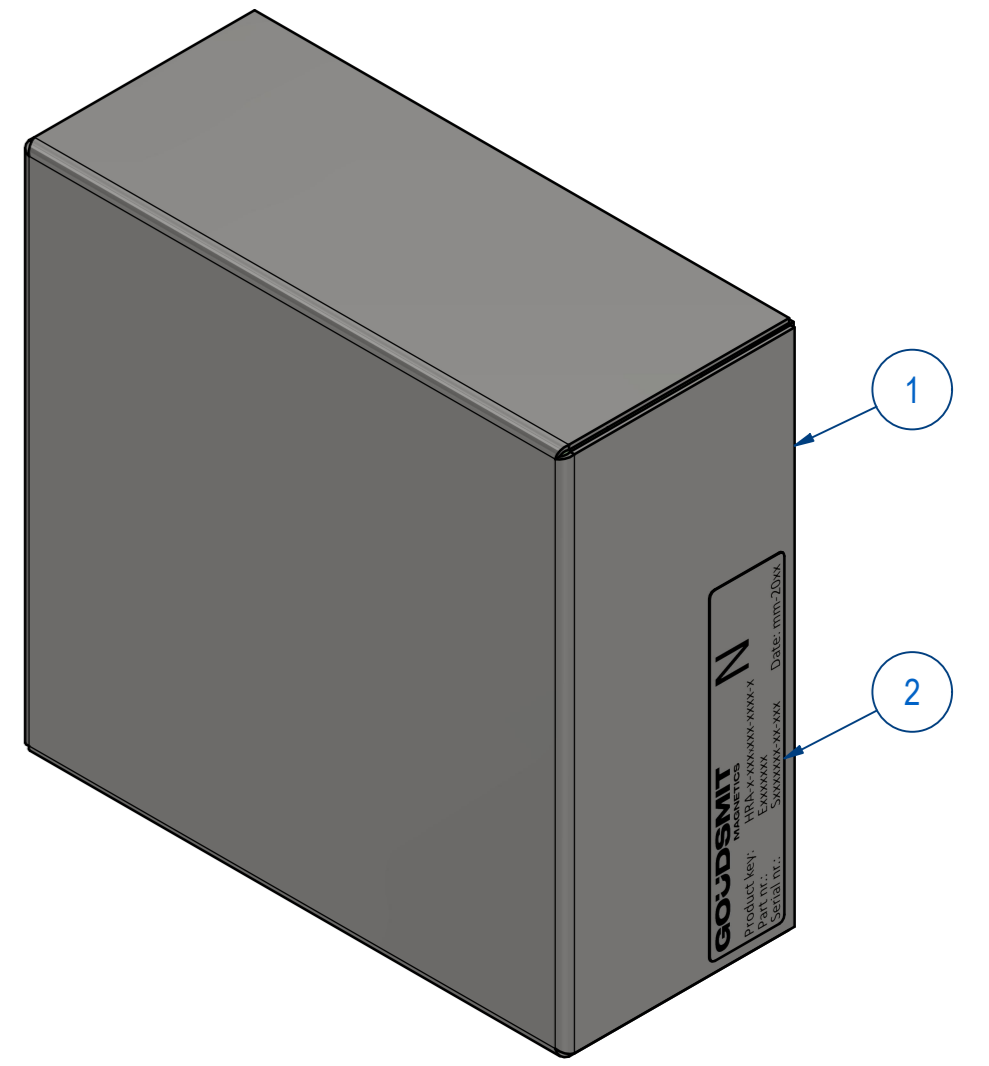
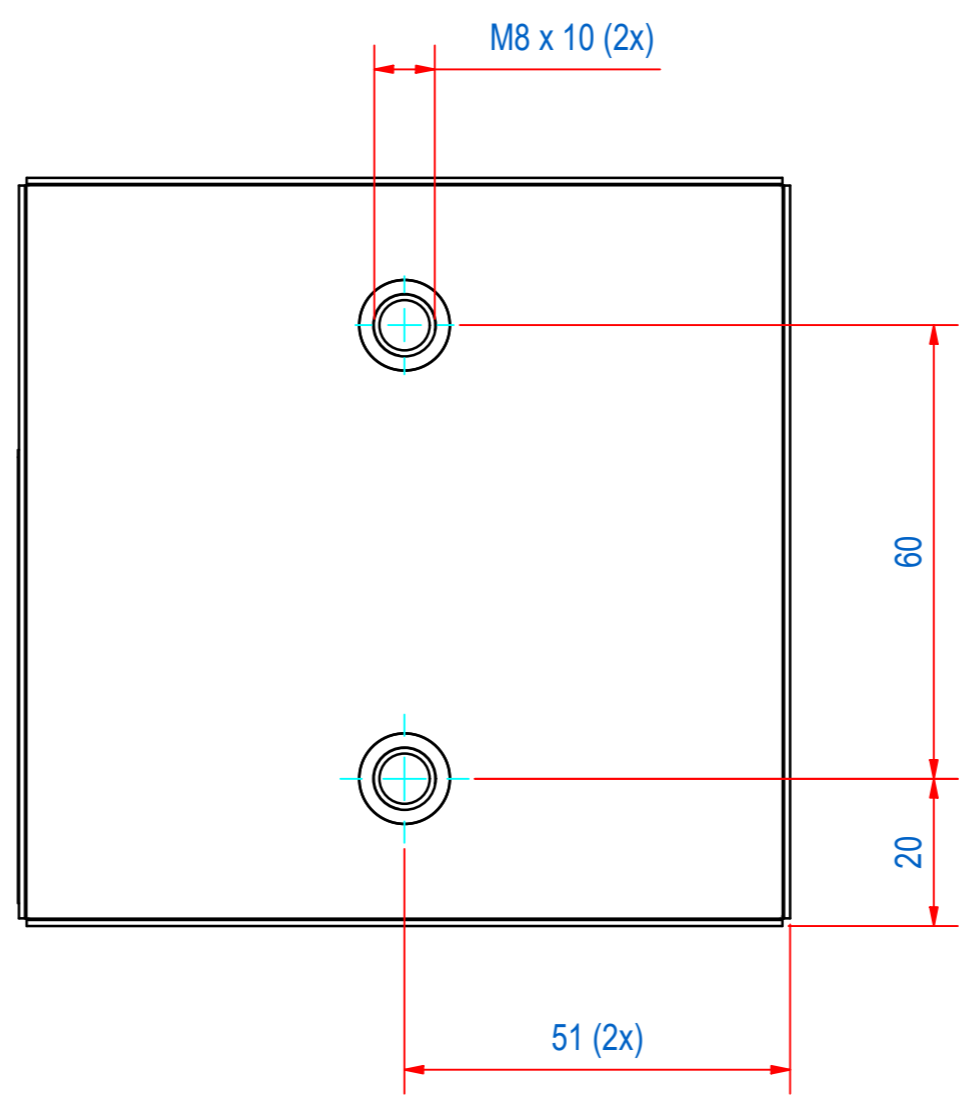
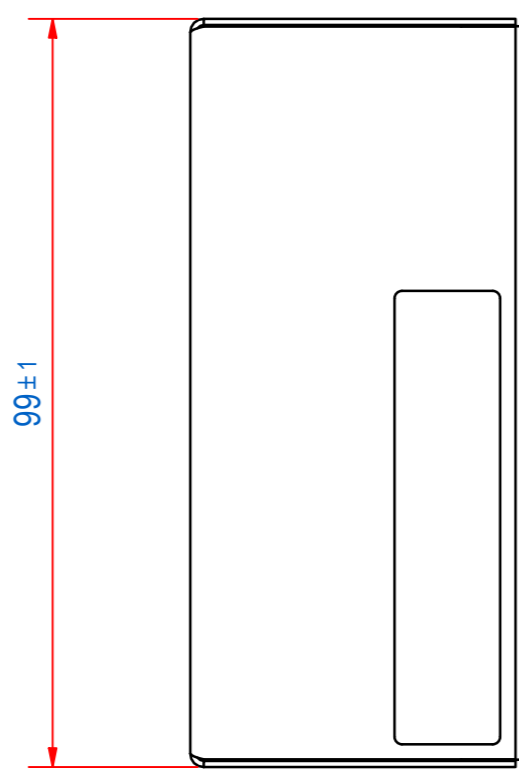
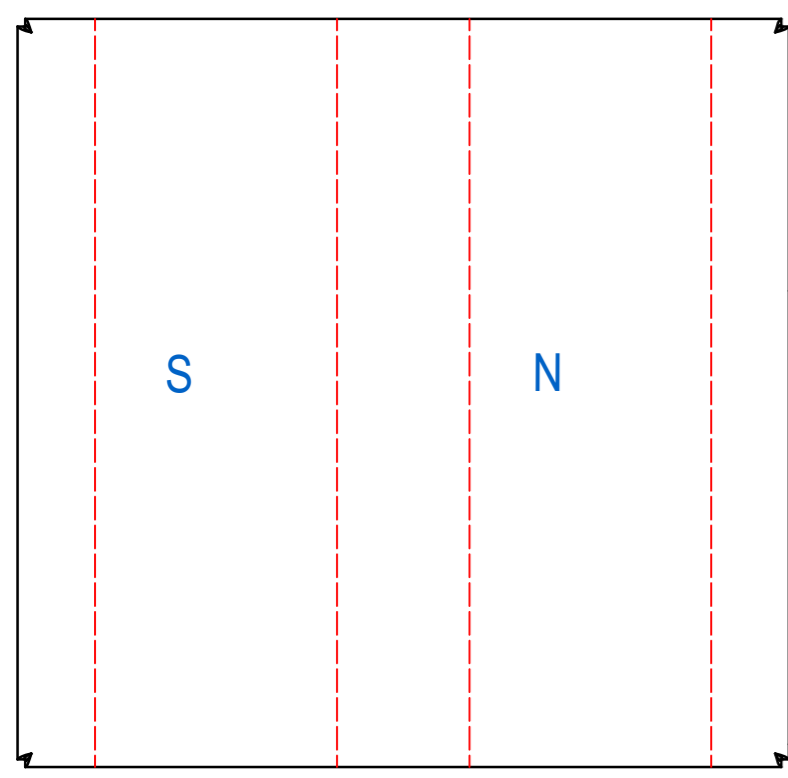

| ITEM | QTY | PART NUMBER | DESCRIPTION | Dimensions |
|------|-----|-------------|------------------------|------------|
| 2 | 1 | E0156615 | HRA-TYPE PLATE STICKER | |
| 1 | 1 | E0157106 | HRA-WELD ASSY | |

| RAW MAT. | Quantity | Material Number | Material Description | Length (mm) | Width (mm) |
|----------|----------|-----------------|----------------------|-------------|------------|
| | 1 | | | | |

| | | | |
|--|--|---|---|
| Sheet: A2 Drawn: PB Date: 2-4-2014 Spare part: False Quick search: TBAA14 | Weight (kg): 2,0 Source: MC-C | GOUDSMIT MAGNETICS <small>© All rights reserved. Reproduction is not permitted without written permission of GOUDSMIT Magnetic Systems BV</small> | General tolerance: ISO 2768 - mK Drawn according: ISO268; ISO1101; ISO2553 Status: Standard Customer reference number: Document number: TBAA010014 Doc.Rev: A |
| Description: HRA-F-102x44-AA-0100-R-B | | | Part number: TBAA010014 Rev: A |