

REV	DATE	BY	DESCRIPTION
-	2-4-2014	PB	NEW VAULT, NEW REVISION. NOTHING CHANGED. OLD REV WAS A
A	4-1-2023	DK	SOURCE CODE ADDED, TYPE PLATE STICKER ADDED

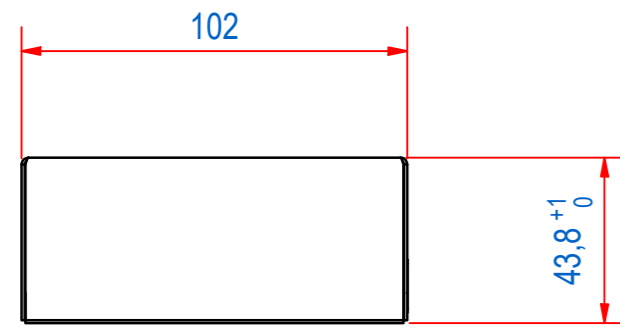
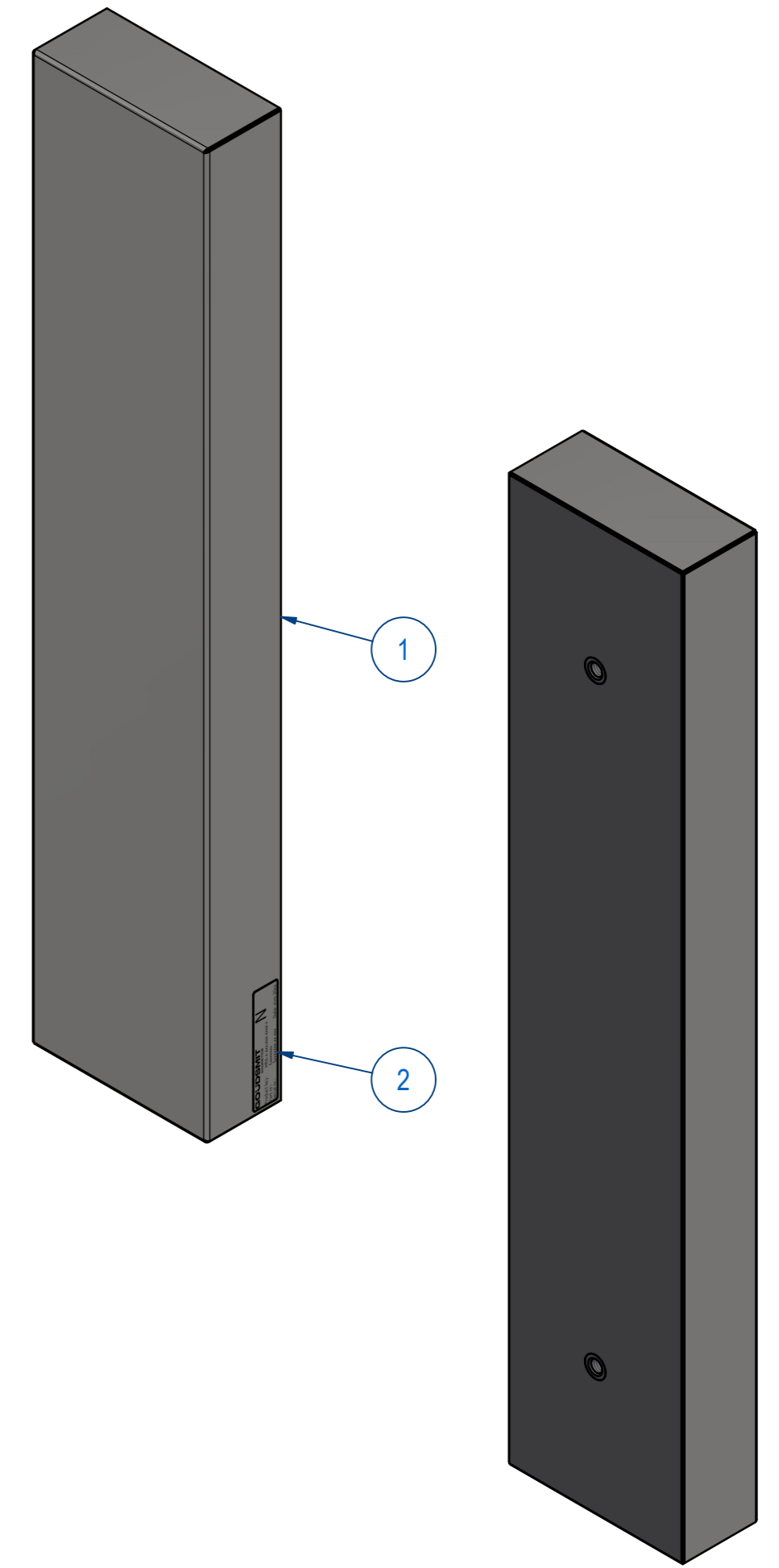
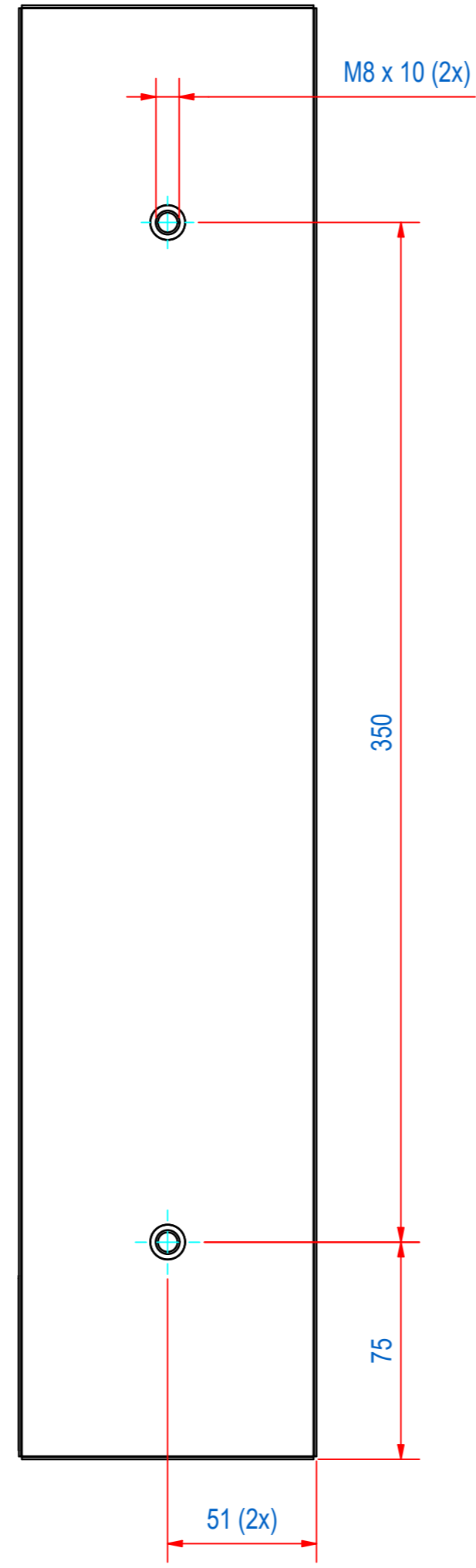
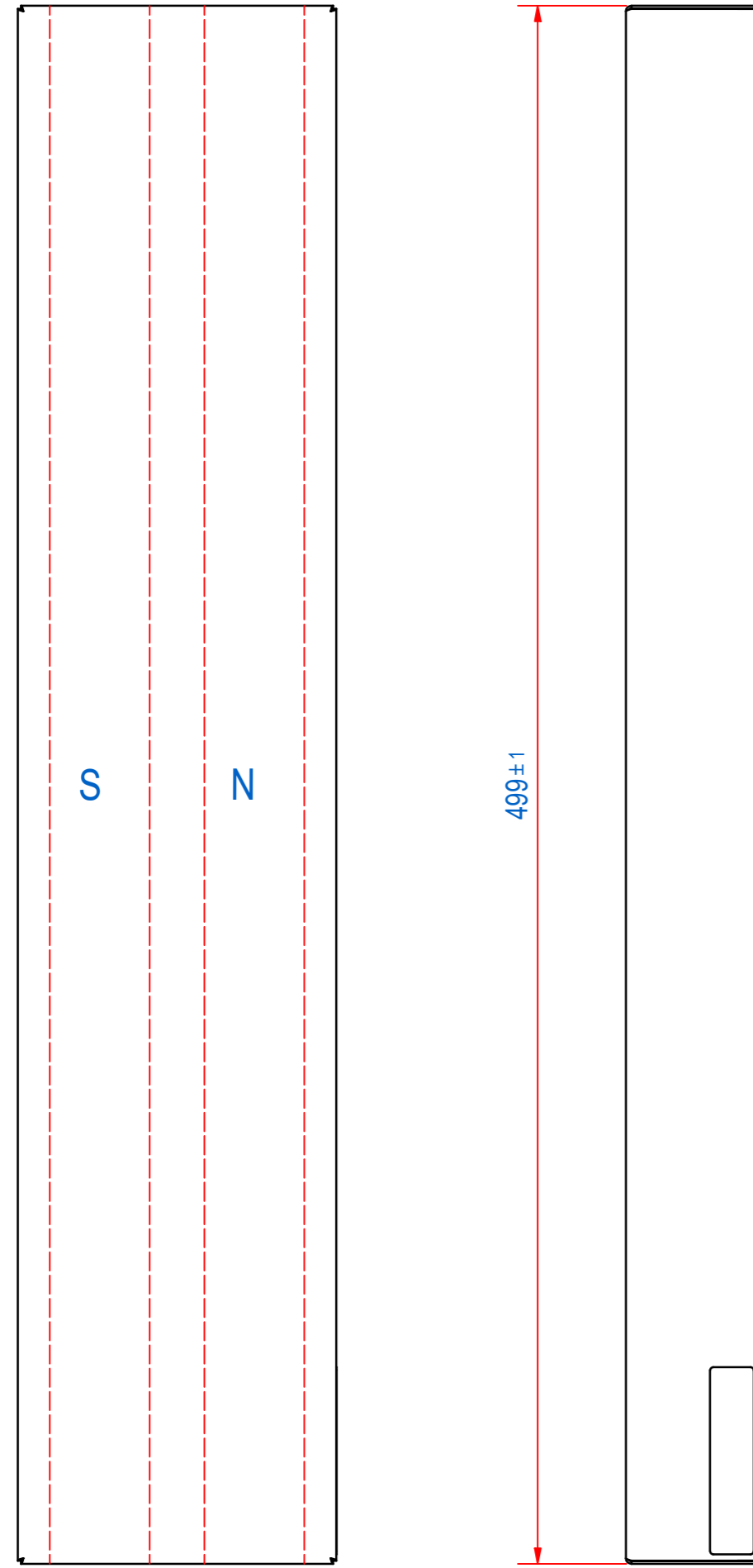

ITEM	QTY	PART NUMBER	DESCRIPTION	Dimensions
2	1	E0156615	HRA-TYPE PLATE STICKER	
1	1	E0157111	HRA-WELD ASSY	
RAW MAT.	1			
Quantity		Material Number	Material Description	Length (mm) Width (mm)
Sheet:	A2	Extra info:	MAGNETIC RAIL	General tolerance: ISO 2768- mK
Drawn:	PB	Weight (kg):	9,9	Drawn according: ISO268; ISO1101; ISO2553
Date:	2-4-2014	Status:	Standard	
Spare part:	False	Source:	MC-C	Customer reference number:
Quick search:	TBAA14			Document number: TBAA050014 Doc.Rev: A
Description:	HRA-F-102x44-AA-0500-R-B			Part number: TBAA050014 Rev: A