

REV	DATE	BY	DESCRIPTION
-	28-5-2014	BS	NEW VAULT, NEW REVISION NOTHING CHANGED. OLD REV WAS C
A	4-1-2023	DK	STICKER AND SOURCE CODE ADDED
B	30-1-2023	DK	VIEWS UPDATED

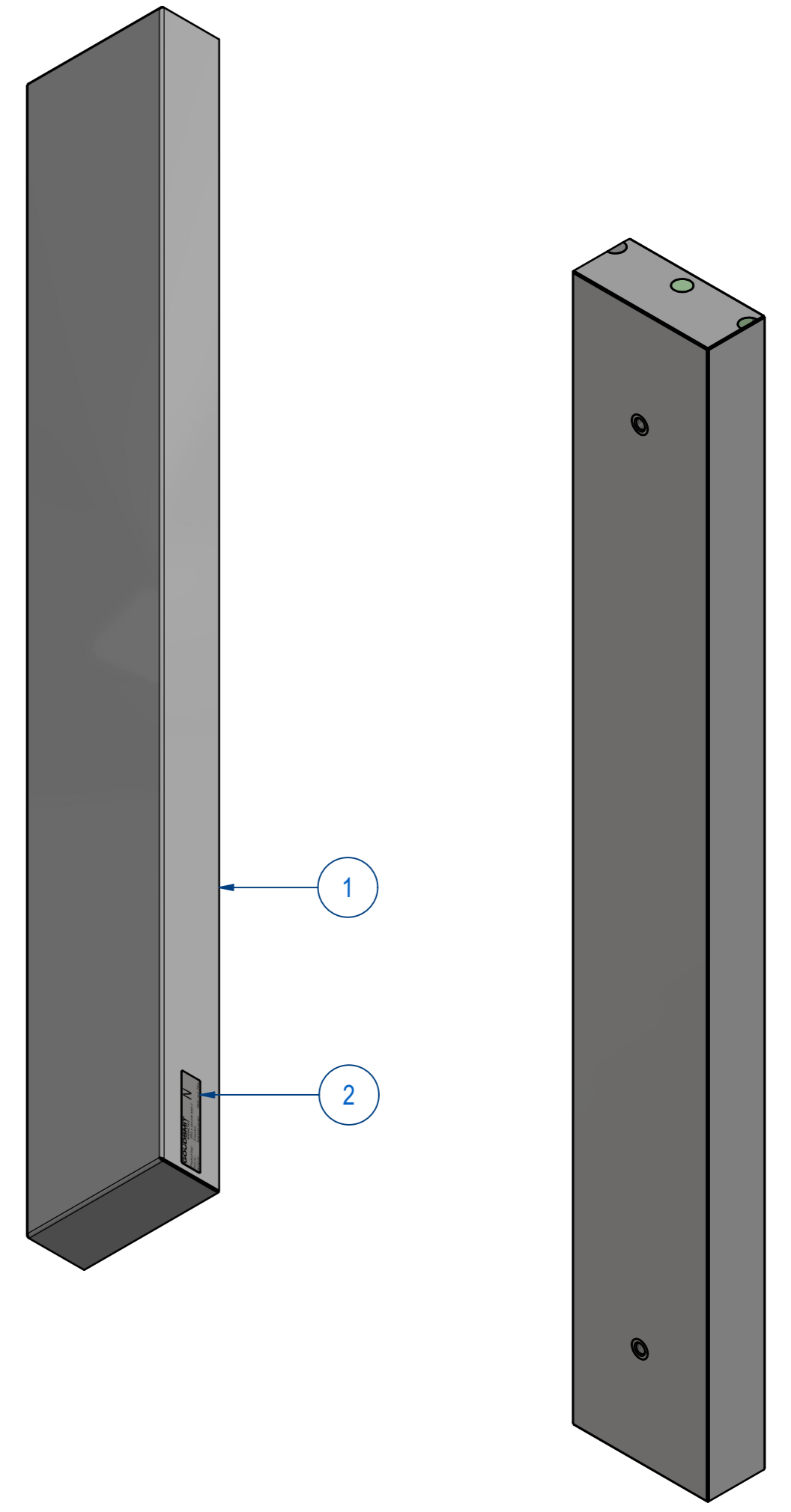

ITEM	QTY	PART NUMBER	DESCRIPTION	Dimensions
2	1	E0156683	HRA-TYPE PLATE ETCH	
1	1	E0157050	HRA-WELD AND MOULDING ASSY	
RAW MAT.	1			
Quantity		Material Number	Material Description	Length (mm) Width (mm)
Sheet:	A2	Extra info:	MAGNETIC RAIL	General tolerance: ISO 2768- mK
Drawn:	BS	Weight (kg):	15 REINFORCED WATERTIGHT AISI	Drawn according: ISO268; ISO1101; ISO2553
Date:	28-5-2014			Status: Standard
Spare part:	False	Source:	MC-C	Customer reference number:
Quick search:	TBAA54			Document number: TBAA075054 Doc.Rev: B
Description:	HRA-F-102x44-AA-0750-R-W			Part number: TBAA075054 Rev: B

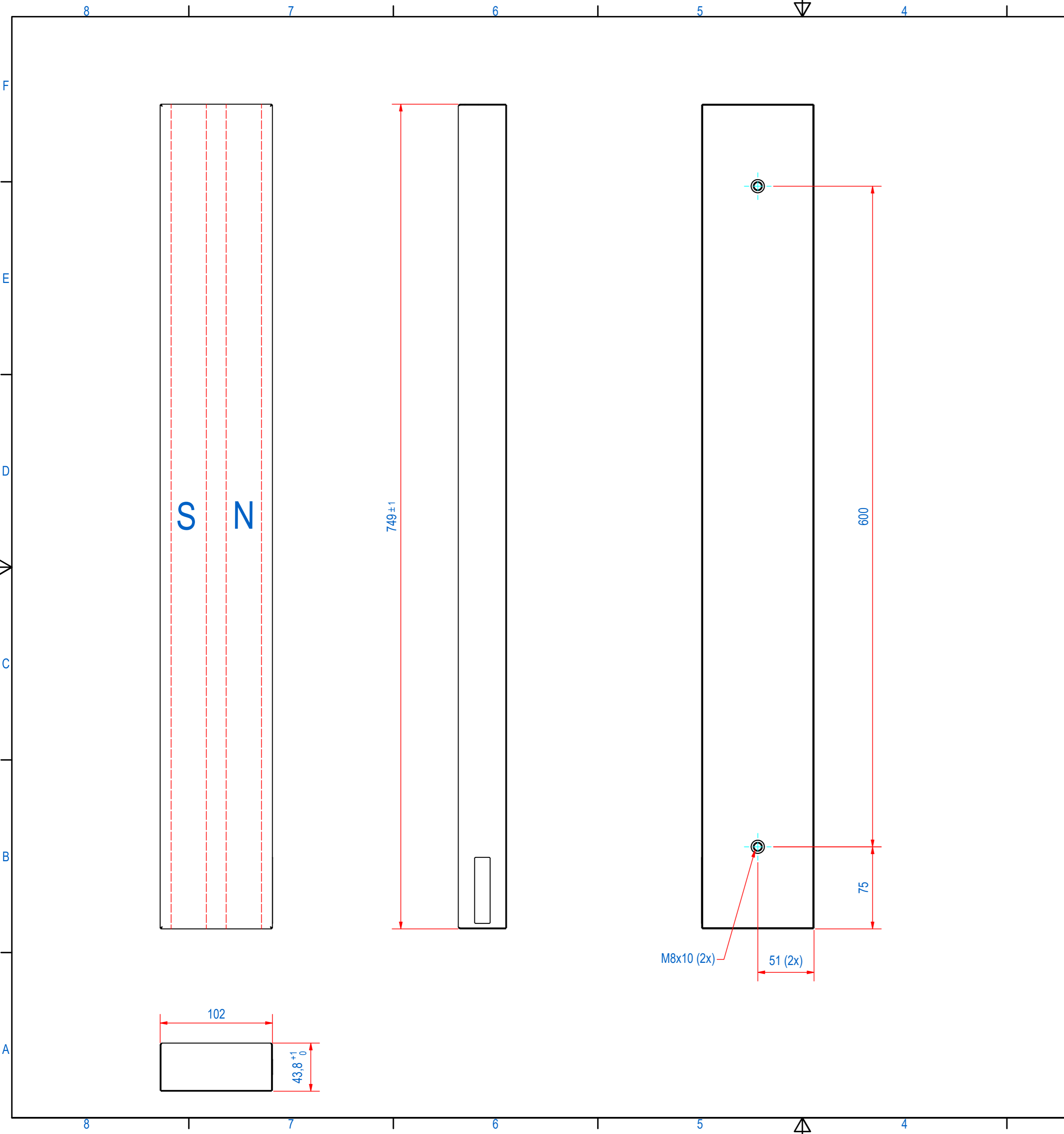

© All rights reserved. Reproduction is not permitted without written permission of GOUDSMIT Magnetic Systems BV