

DOC.NR.	REV	DATE	BY	DESCRIPTION
TBAB030002	A	8-7-2022	PB	WELD ASSY ADDED
TBAB030002	B	4-1-2023	DK	STICKER AND SOURCE CODE ADDED
TBAB030002	C	31-1-2023	DK	TOLERANCE OF HEIGHT CHANGED FROM +0.5 TO +1

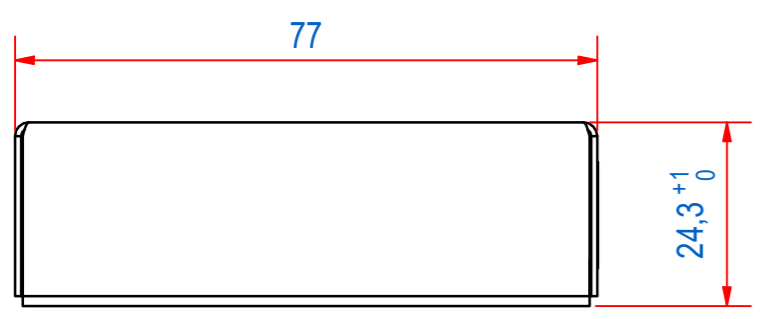

ITEM	QTY	PART NUMBER	DESCRIPTION	Dimensions
2	1	E0156615	HRA-TYPE PLATE STICKER	
1	1	E0153737	HRA-WELD ASSY	
RAW MAT.	1			
Quantity	Material Number	Material Description	Length (mm)	Width (mm)
Sheet: A2	Extra info: MAGNETIC RAIL DECREASING FIELD	General tolerance: ISO 2768 - mK		
Drawn: PB	Weight (kg): 1,8	Drawn according: ISO268; ISO1101; ISO2553		
Date: 1-7-2013	Source: MC-C	Status: Standard		
Spare part: False	Quick search: TBAB02	Customer reference number:	Document number: TBAB030002	Doc.Rev: C
Description: HRA-F-077x24-AB-0300-B-B			Part number: TBAB030002	Rev: C

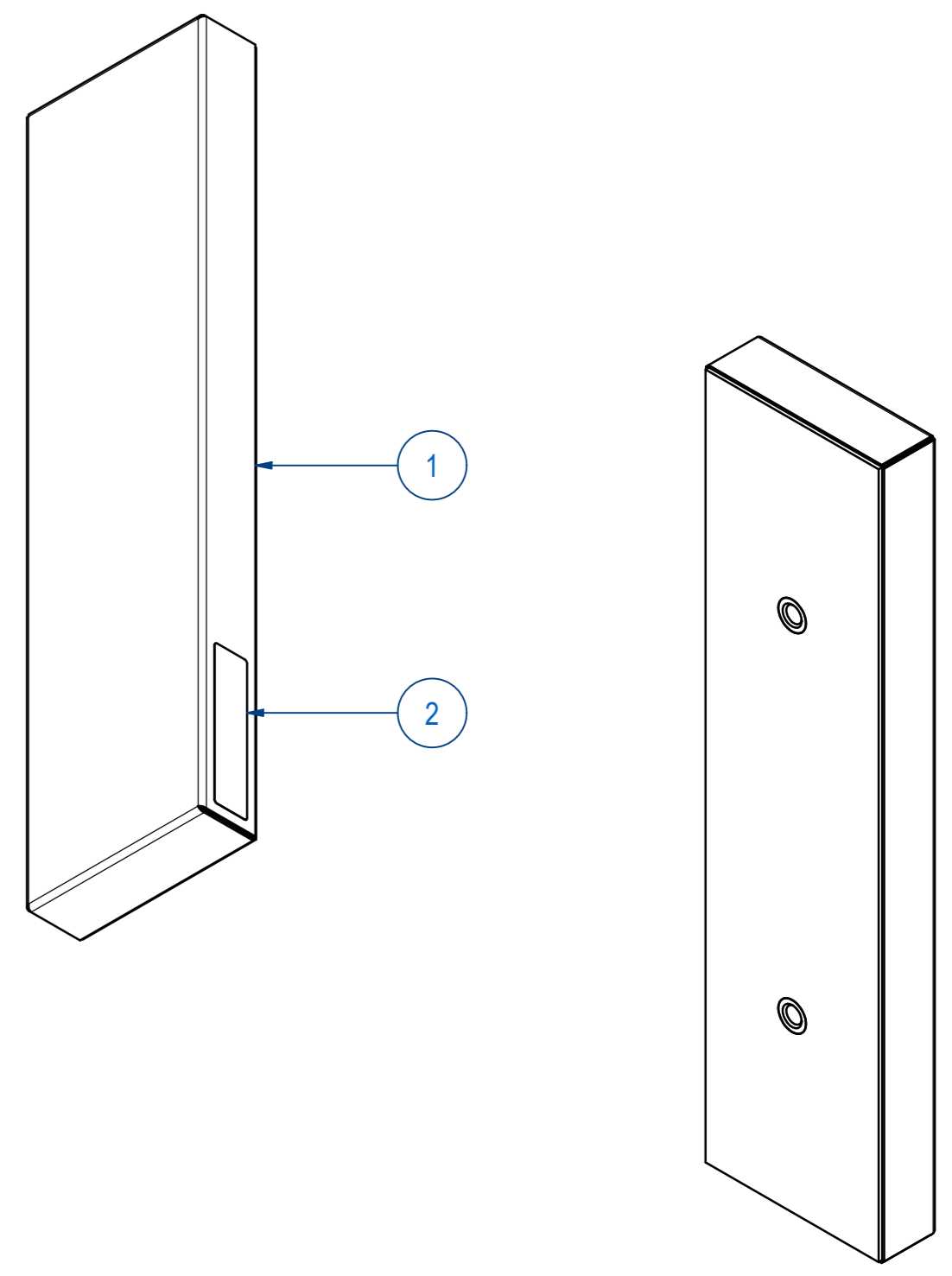
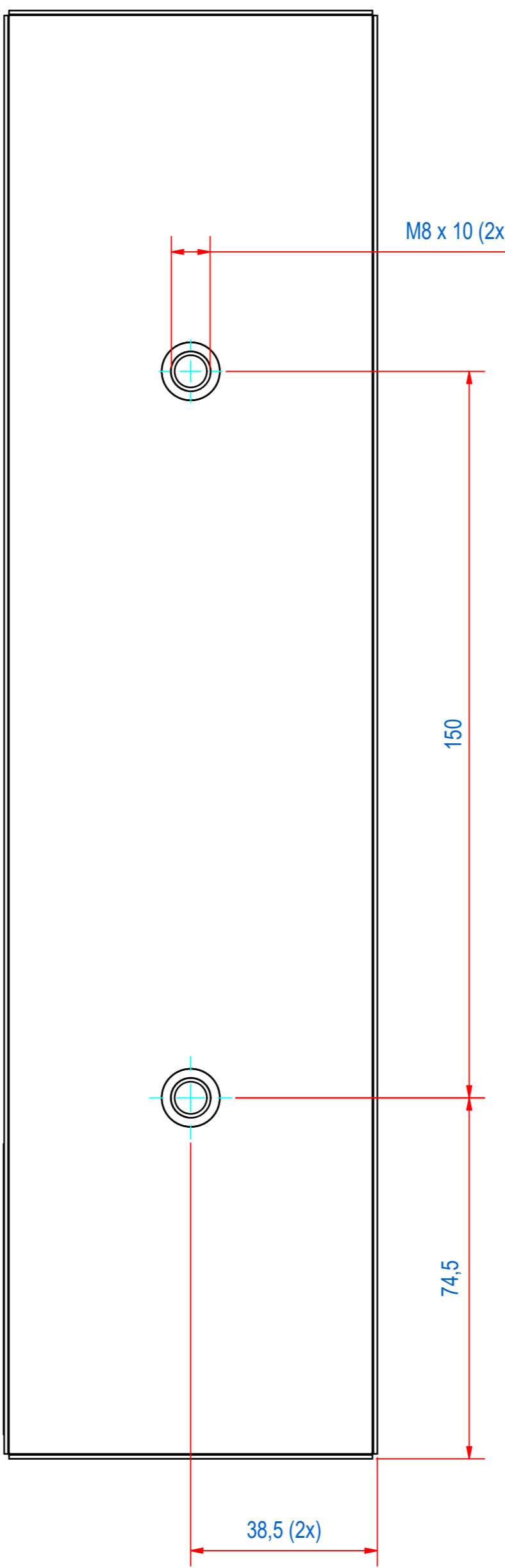
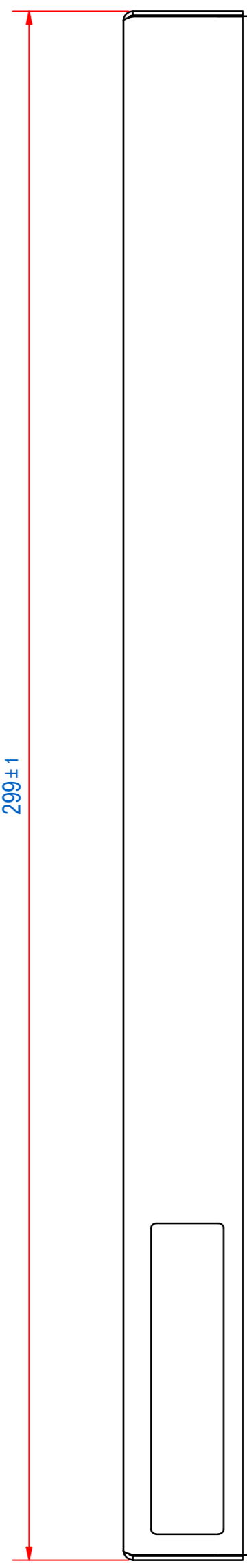
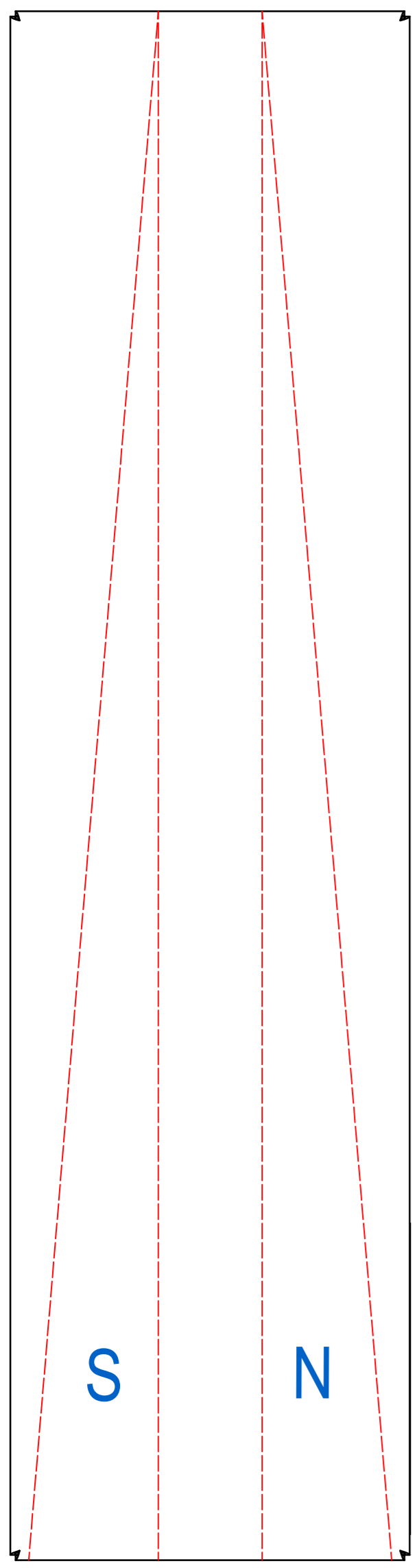

© All rights reserved. Reproduction is not permitted without written permission of GOUDSMIT Magnetic Systems BV