

REV	DATE	BY	DESCRIPTION
A	8-9-2022	PB	WELD ASSY ADDED
B	4-1-2023	DK	WELD ANNOTATIONS CORRECTED
C	7-2-2023	DK	TOLERANCE OF HEIGHT TO +1 WAS +0.5

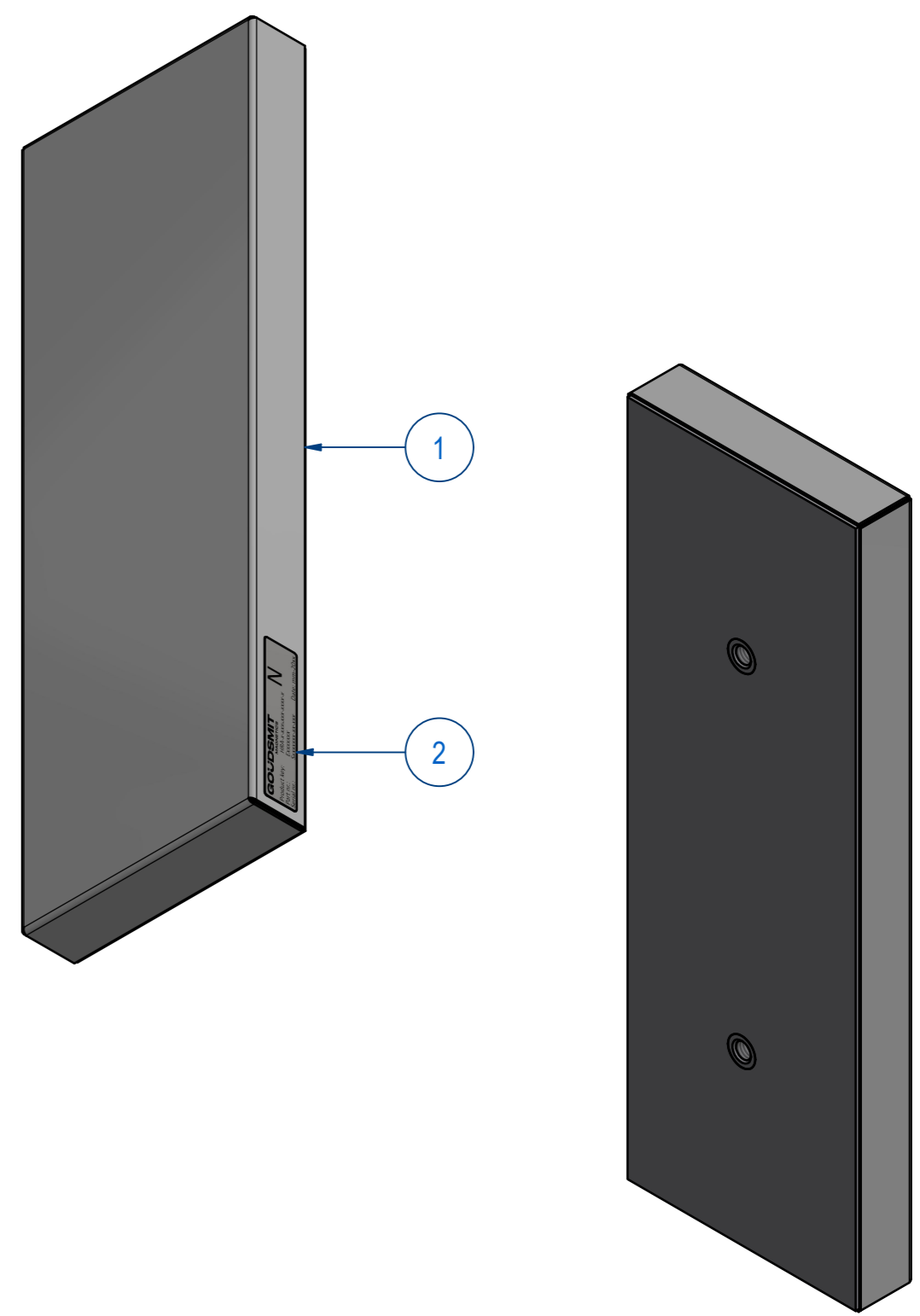
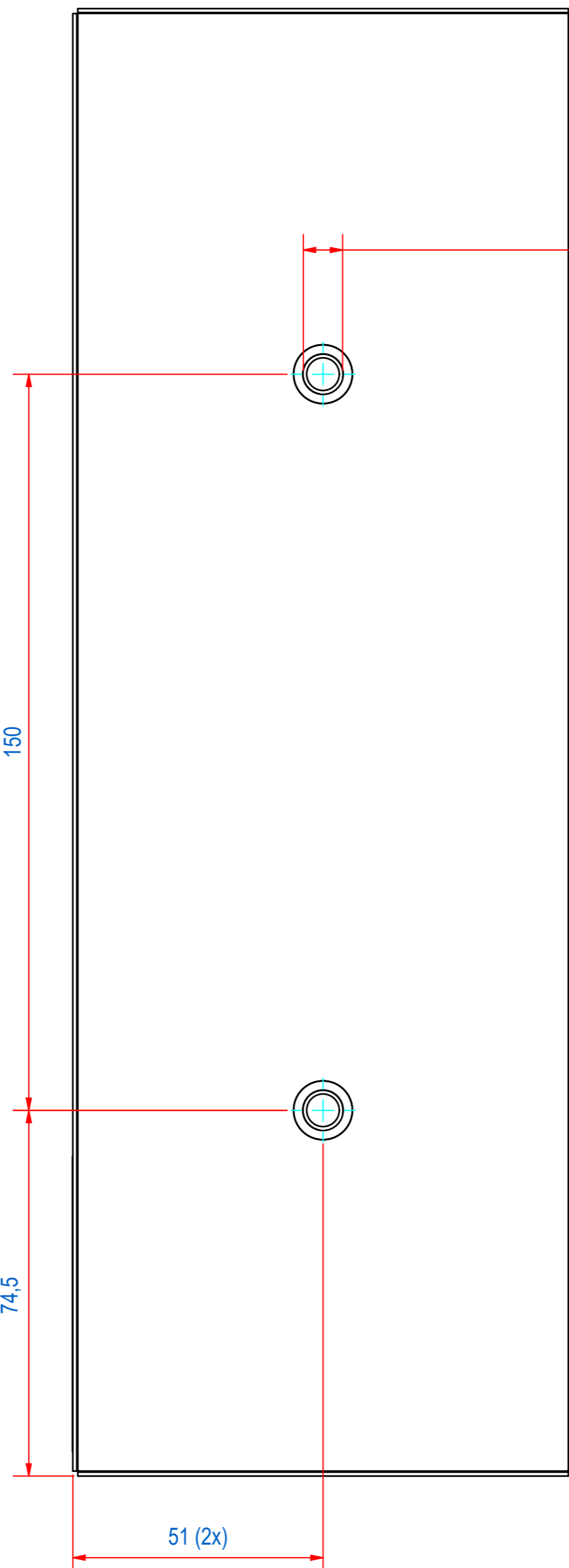
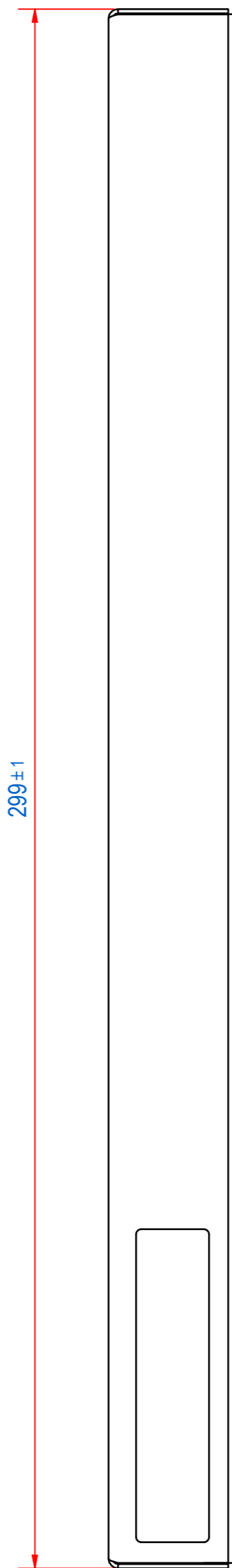
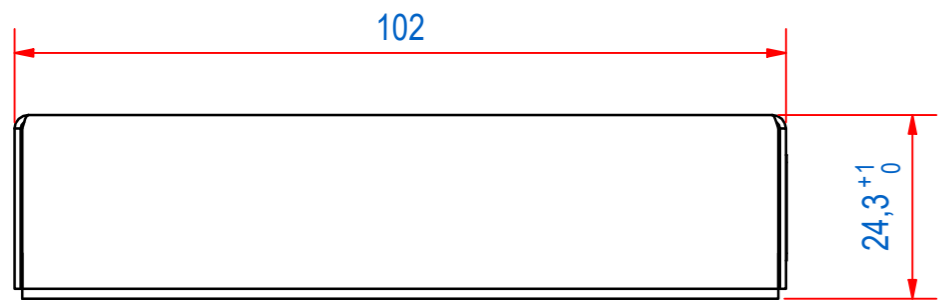
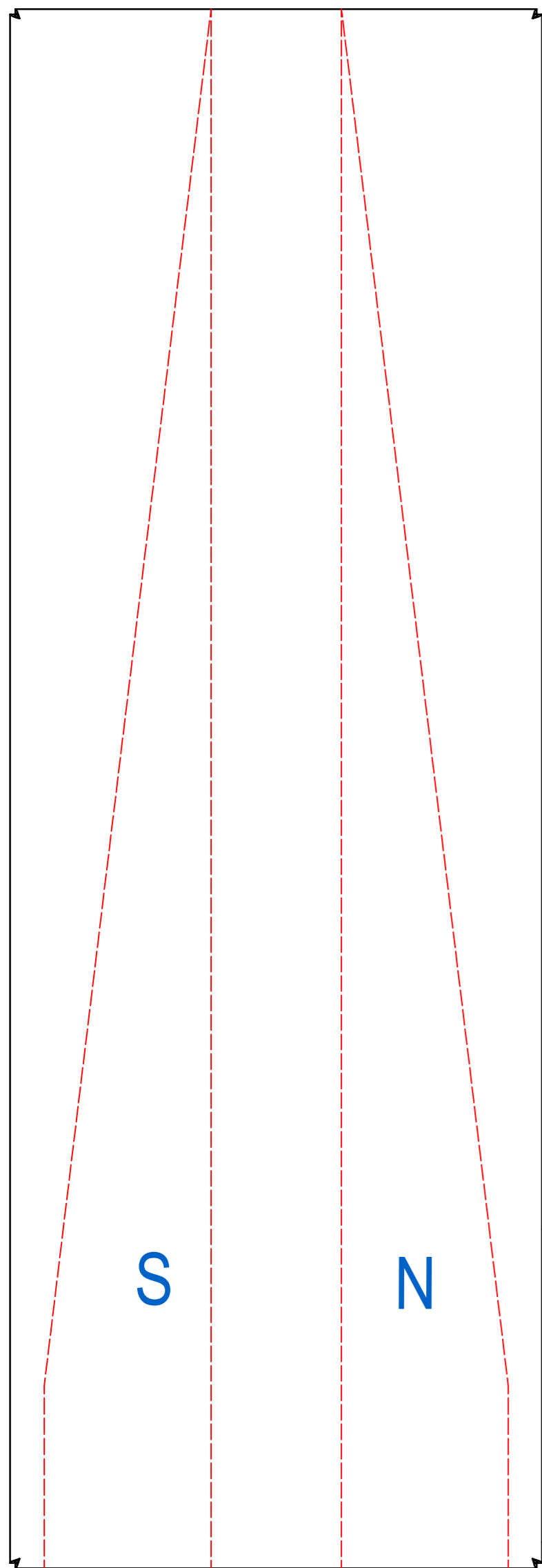

ITEM	QTY	PART NUMBER	DESCRIPTION	Dimensions
2	1	E0156615	HRA-TYPE PLATE STICKER	
1	1	E0154837	HRA-WELD ASSY	
RAW MAT.	1			
Quantity	Material Number	Material Description	Length (mm)	Width (mm)
Sheet: A2	Extra info: MAGNETIC RAIL DECREASING FIELD	General tolerance: ISO 2768 - mK		
Drawn: PB	Weight (kg): 2,5	Drawn according: ISO268; ISO1101; ISO2553		
Date: 15-11-2013	Source: MC-C	Status: Standard		
Spare part: False	Quick search: TBAB03	Customer reference number:		
Description: HRA-F-102x24-AB-0300-B-B	Document number: TBAB030003	Doc.Rev: C		
	Part number: TBAB030003	Rev: C		