

REV	DATE	BY	DESCRIPTION
-	27-5-2014	BS	NEW VAULT, NOTHING CHANGED, IS EQUAL TO OLD REVISION A
A	4-1-2023	DK	STICKER AND SOURCE CODE ADDED AND FILES DEMOTED
B	7-2-2023	DK	VIEWS UPDATED

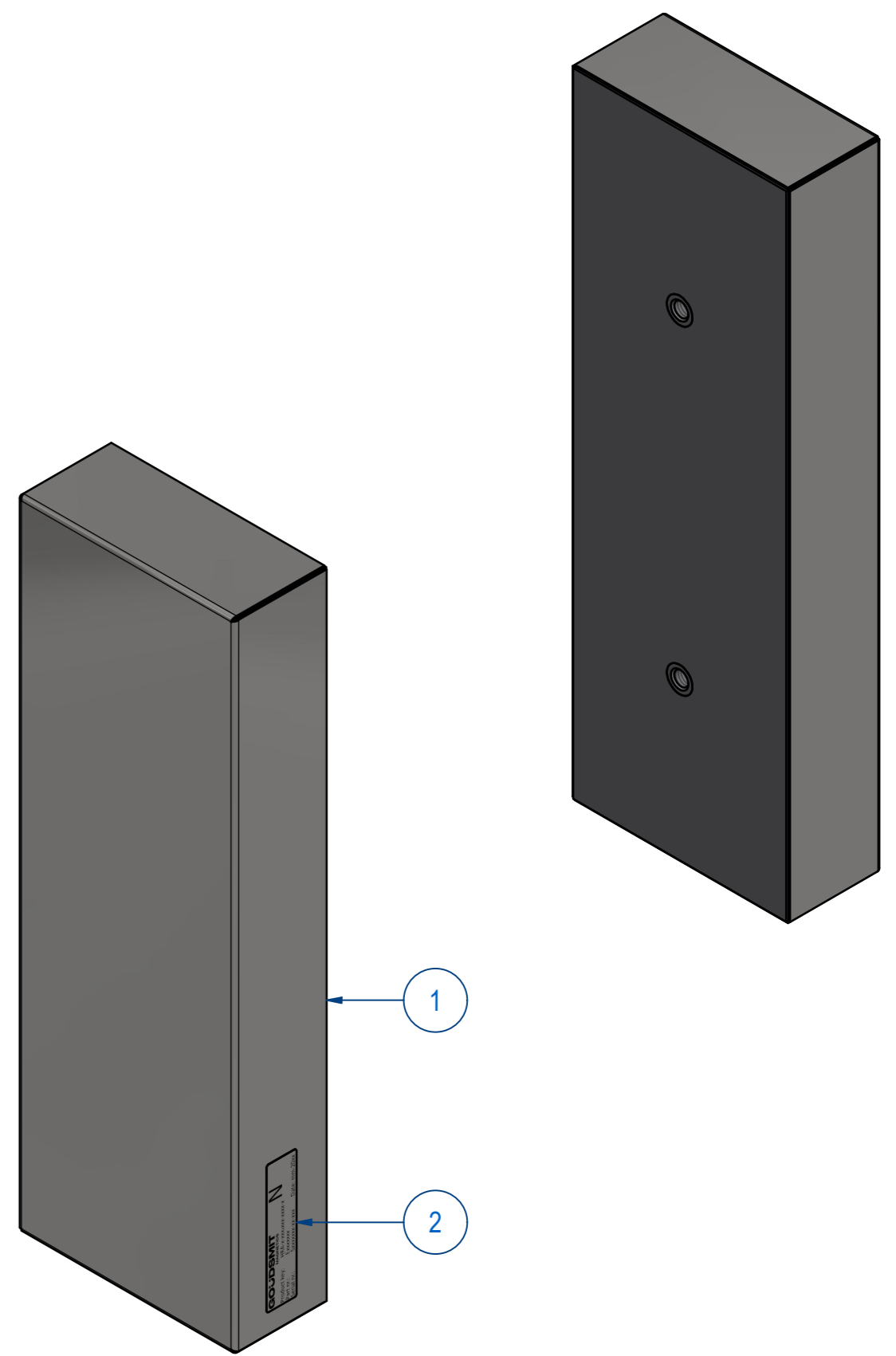
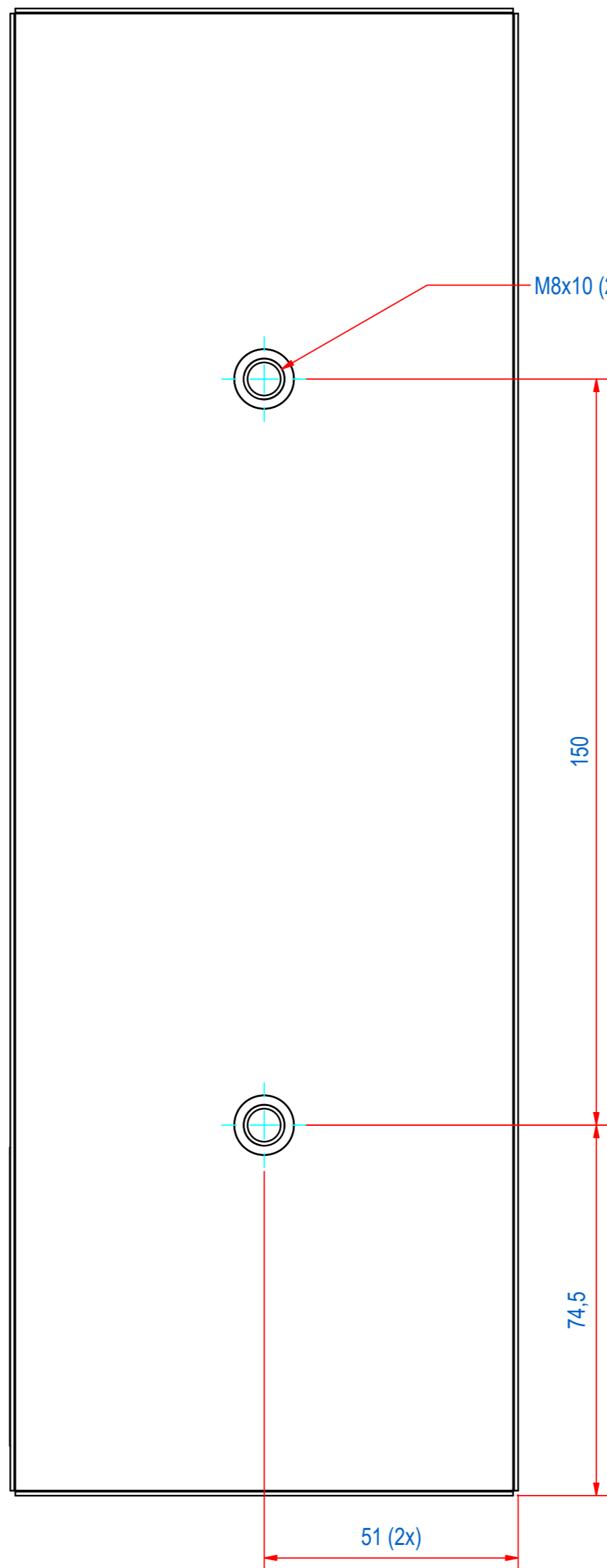
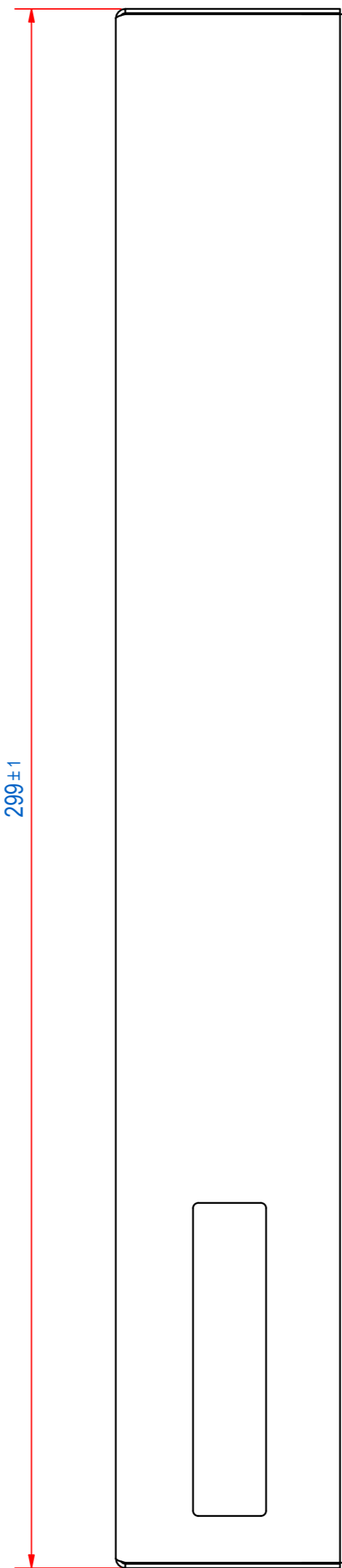
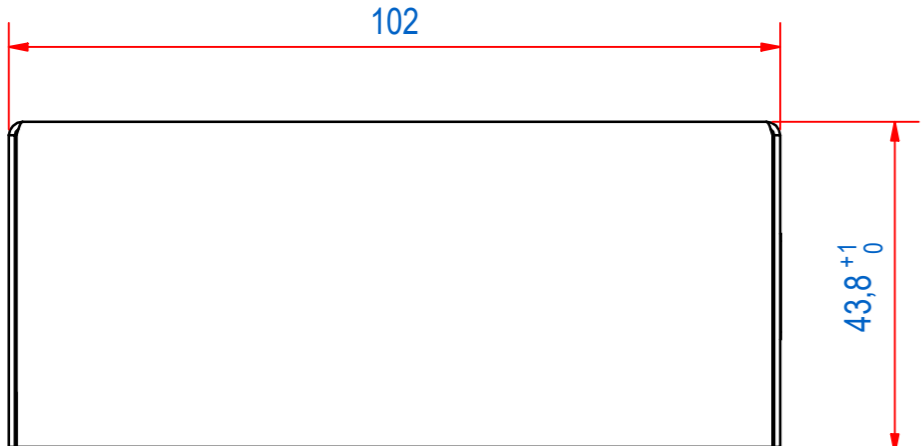
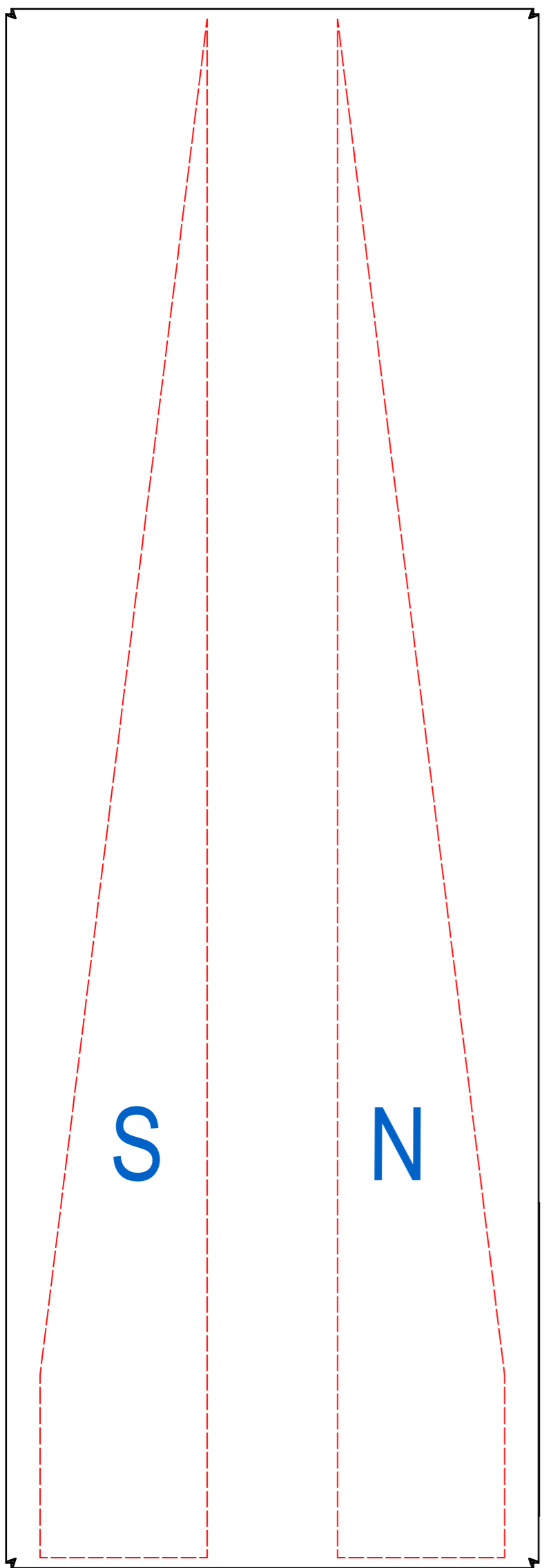

ITEM	QTY	PART NUMBER	DESCRIPTION	Dimensions
2	1	E0156615	HRA-TYPE PLATE STICKER	
1	1	E0157012	HRA-WELD ASSY	

RAW MAT.	Quantity	Material Number	Material Description	Length (mm)	Width (mm)
	1				

Sheet:	A2	Extra info:	WEAKENING SIDE	General tolerance:	ISO 2768- mK
Drawn:	BS	Weight (kg):	3,8	Drawn according:	ISO268; ISO1101; ISO2553
Date:	27-5-2014	Status:	Standard	Customer reference number:	
Spare part:	False	Source:	MC-C	Document number:	TBAB030004
Quick search:	TBAB04	Doc.Rev:	B	Part number:	TBAB030004
Description:	HRA-F-102x44-AB-0300-B-B			Rev:	B



© All rights reserved. Reproduction is not permitted without written permission of GOUDSMIT Magnetic Systems BV