

REV	DATE	BY	DESCRIPTION
-	3-4-2014	PB	NEW VAULT, NEW REVISION. NOTHING CHANGED. OLD REV WAS A
A	4-1-2023	DK	STICKER AND SOURCE CODE ADDED, FILES DEMOTED
B	7-2-2023	DK	VIEWS UPDATED

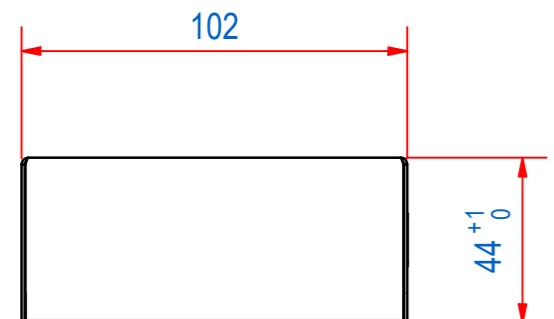

ITEM	QTY	PART NUMBER	DESCRIPTION	Dimensions
2	1	E0156615	HRA-TYPE PLATE STICKER	
1	1	E0157000	HRA-WELD ASSY	
RAW MAT.	1			
Quantity	Material Number	Material Description	Length (mm)	Width (mm)
Sheet: A2	Extra info: MAGNETIC RAIL DECREASING FIELD	General tolerance: ISO 2768- mK		
Drawn: PB	Weight (kg): 7,3	Drawn according: ISO268; ISO1101; ISO2553		
Date: 3-4-2014	Source: MC-C	Status: Standard		
Spare part: False	Quick search: TBAB14	Customer reference number:	Document number: TBAB050014	Doc.Rev: B
Description: HRA-F-102x44-AB-0500-R-B		Part number: TBAB050014	Rev: B	

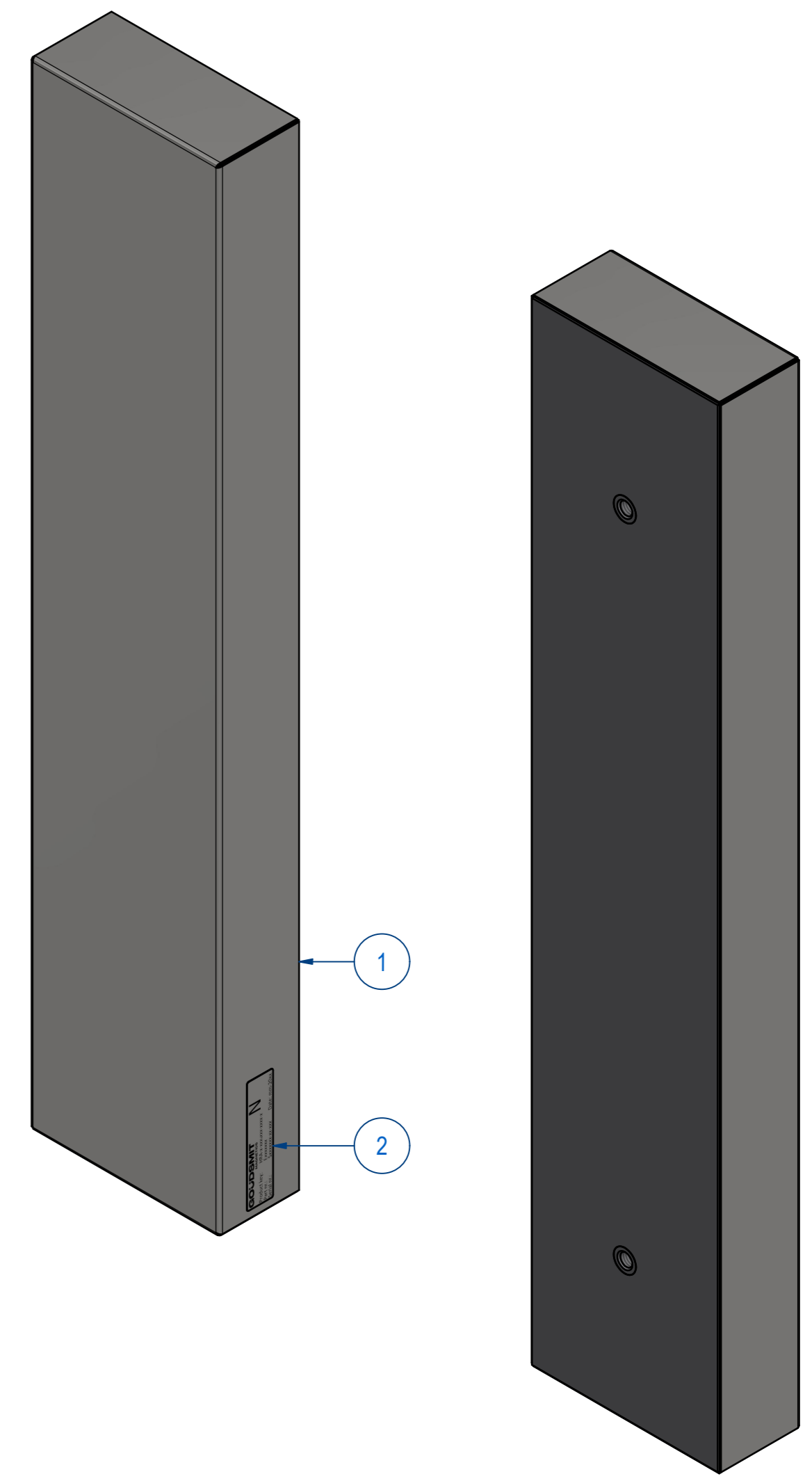
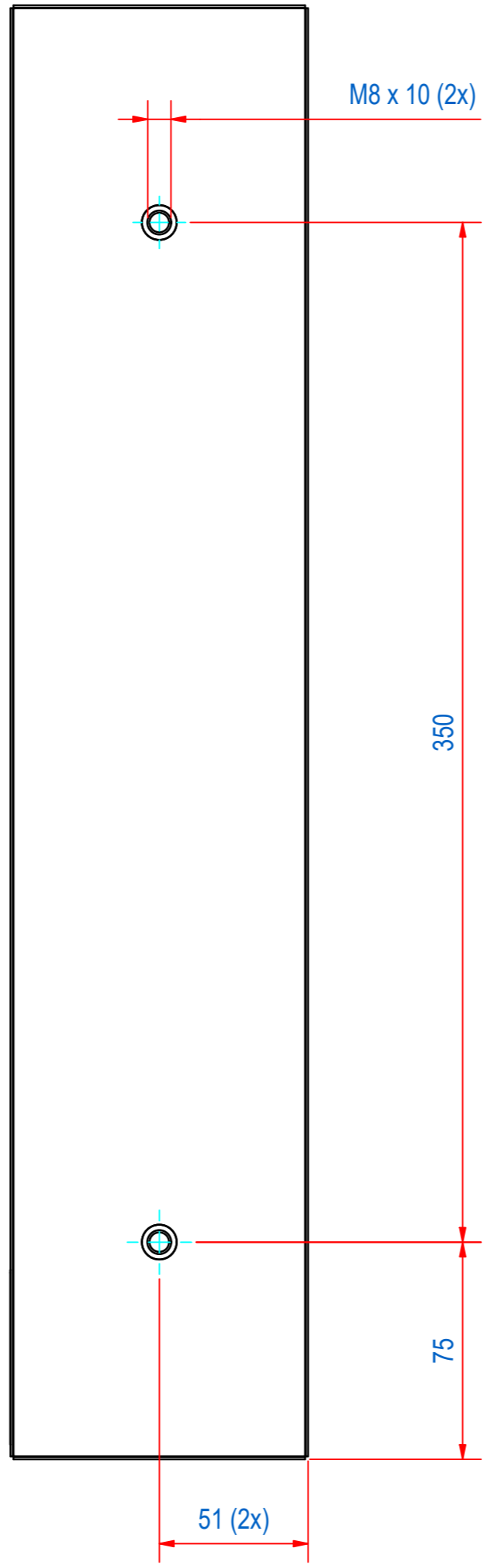
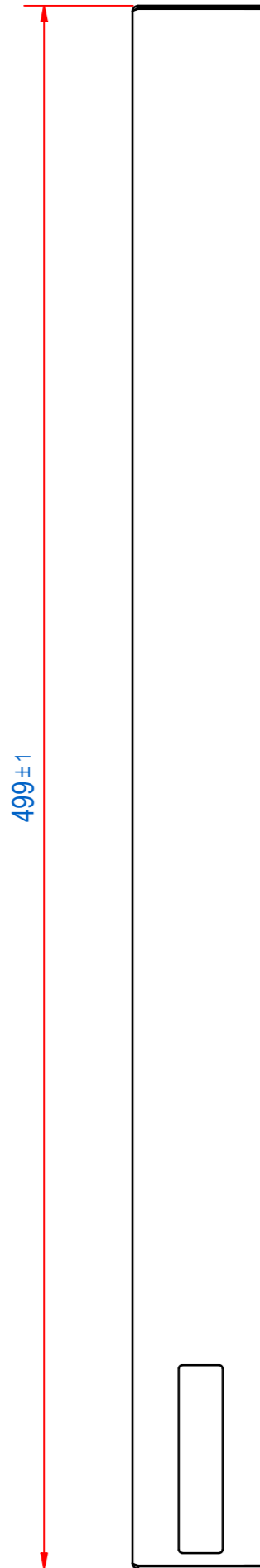
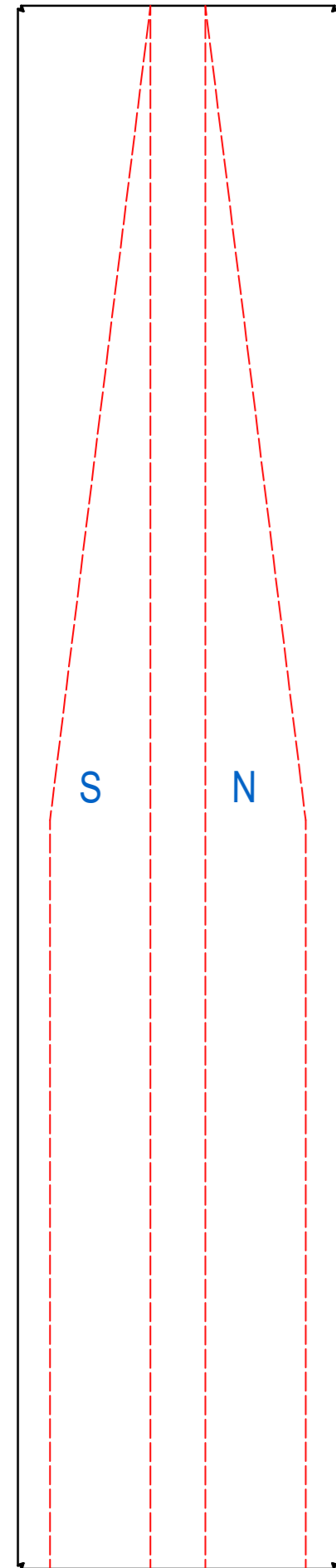

© All rights reserved. Reproduction is not permitted without written permission of GOUDSMIT Magnetic Systems BV