

REV	DATE	BY	DESCRIPTION
-	3-2-2016	PB	NEW VAULT, NEW REVISION NOTHING CHANGED. OLD REV WAS A
A	4-1-2023	DK	ETCH AND SOURCE CODE ADDED AND FILES DEMOTED
B	7-2-2023	DK	VIEWS UPDATED

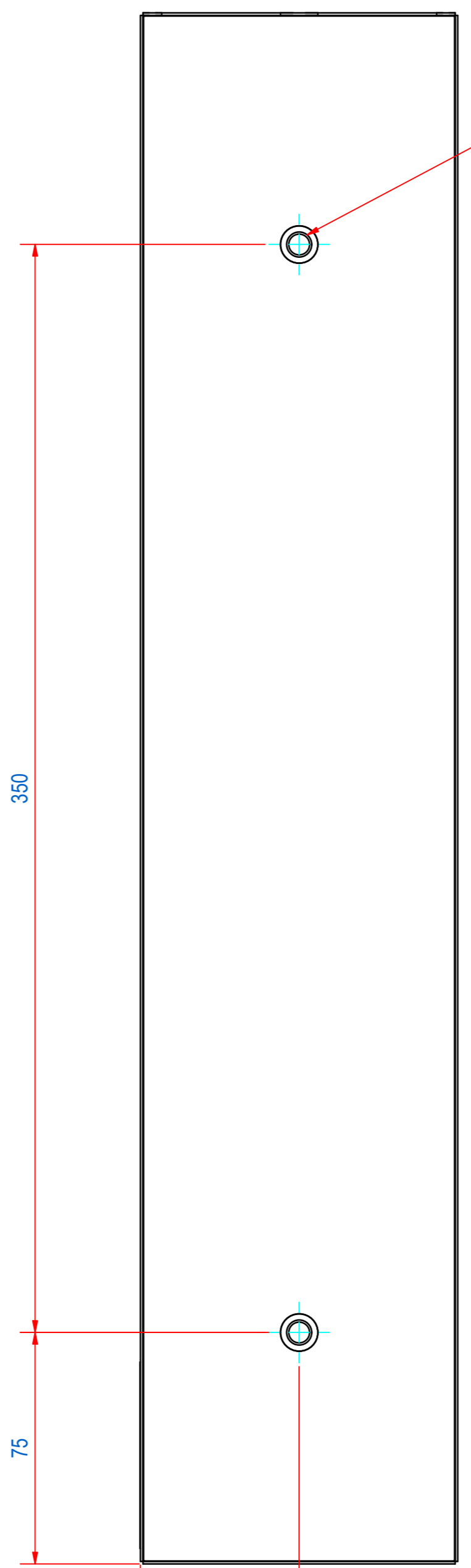

M8x10 (2x)

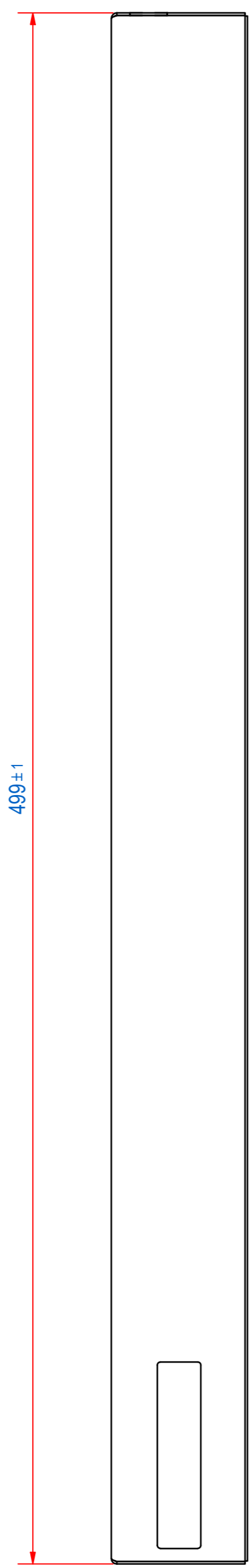
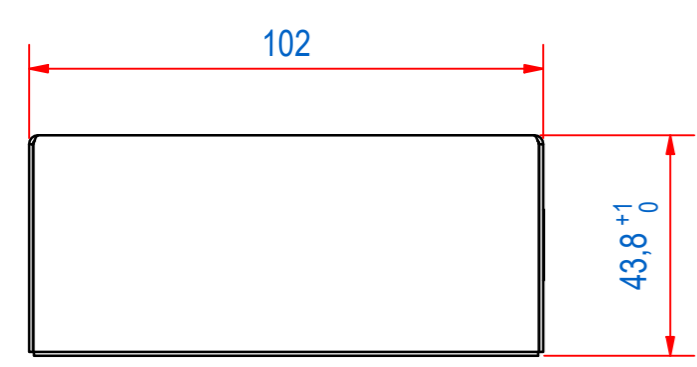
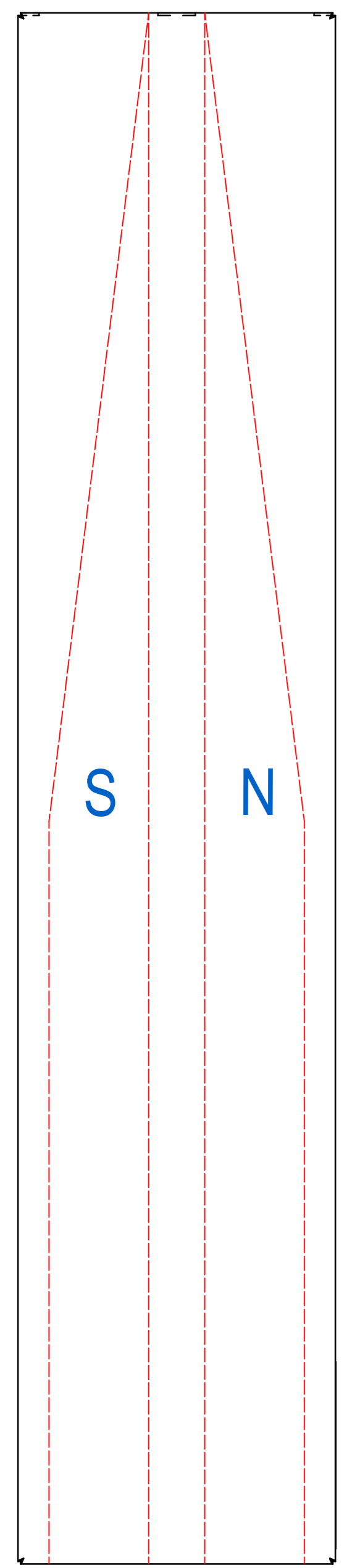
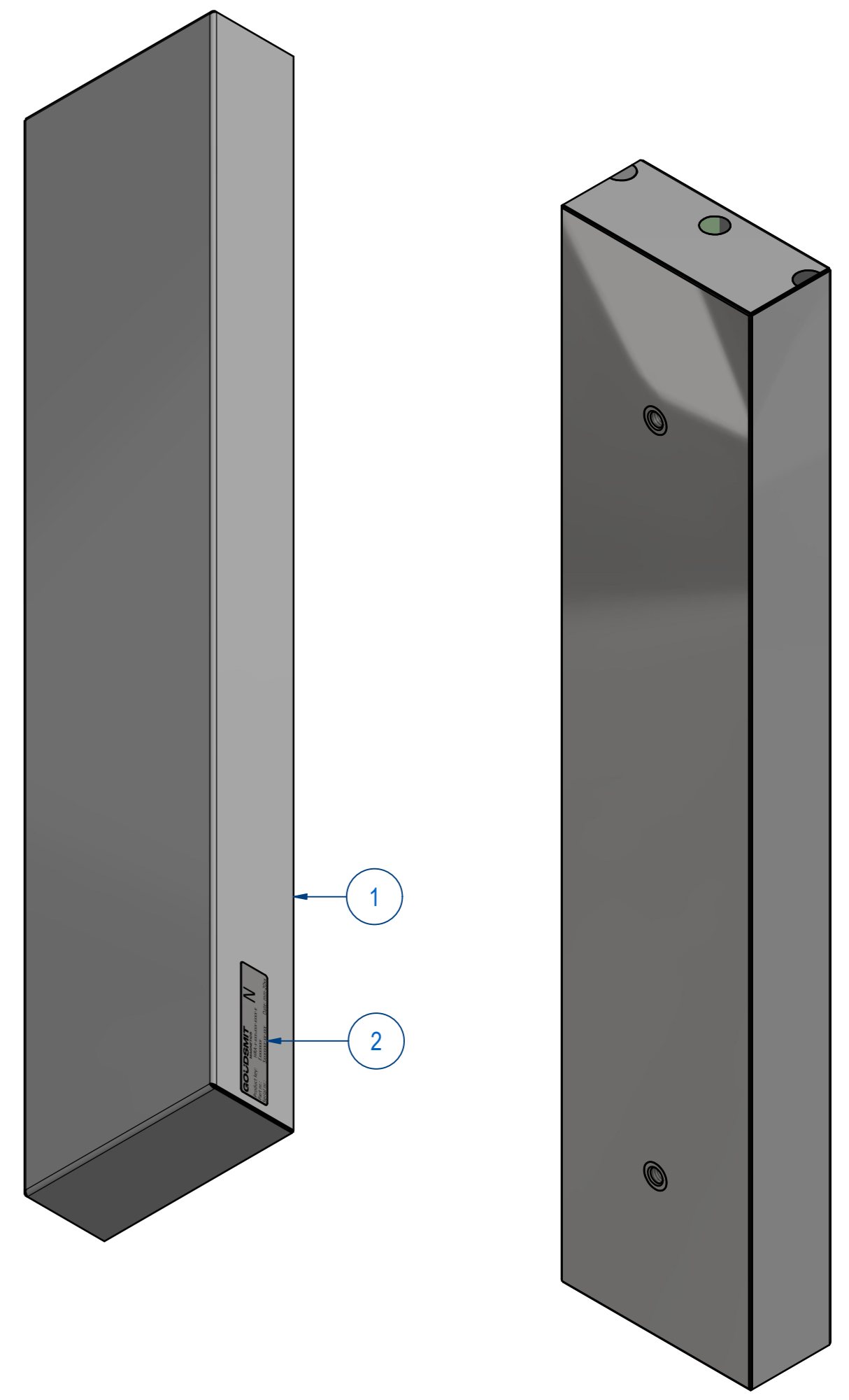

ITEM	QTY	PART NUMBER	DESCRIPTION	Dimensions
2	1	E0156683	HRA-TYPE PLATE ETCH	
1	1	E0156928	HRA-WELD AND MOULD ASSY	
RAW MAT.	1			
Quantity		Material Number	Material Description	Length (mm) Width (mm)
Sheet:	A2	Extra info:	MAGNETIC RAIL	General tolerance:
Drawn:	PB	Weight (kg):	8,0	ISO 2768- mK
Date:	3-2-2016	Source:	MC-C	Drawn according:
Spare part:	False	Quick search:	TBAB54	ISO268; ISO1101; ISO2553
Description:			HRA-F-102x44-AB-0500-R-W	Status:
				Standard
				Customer reference number:
				Document number:
				TBAB050054
				Doc.Rev:
				B
				Part number:
				TBAB050054
				Rev:
				B