

DOC.NR.	REV	DATE	BY	DESCRIPTION
	A	5-10-2022	PB	ADDED WELD ASSY
TBAC030002	B	4-1-2023	DK	STICKER ADDED
TBAC030002	C	1-2-2023	DK	SOURCE CODE ADDED

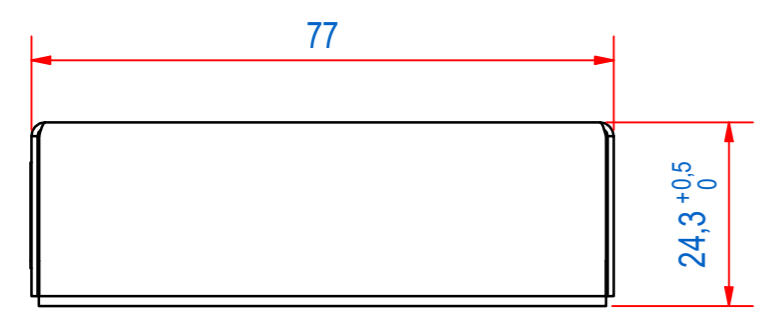
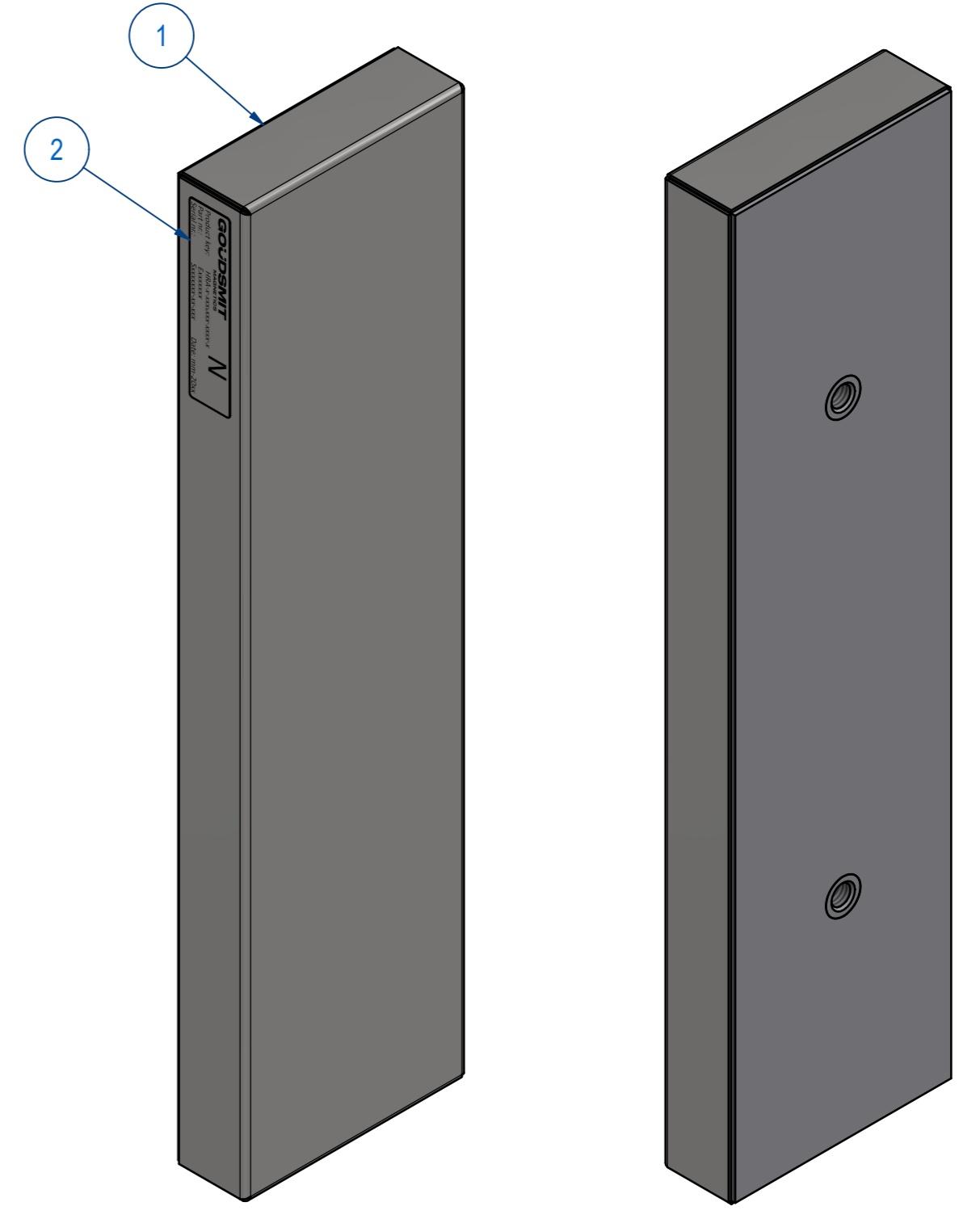
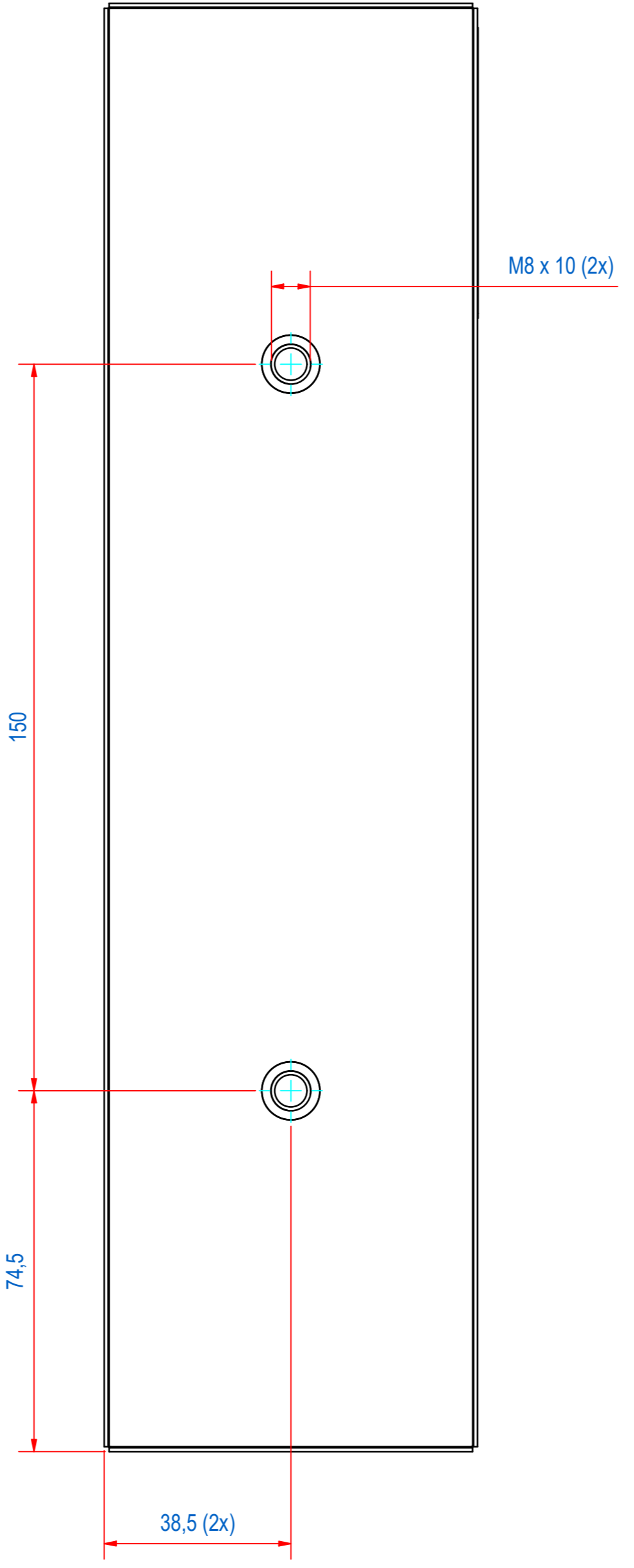
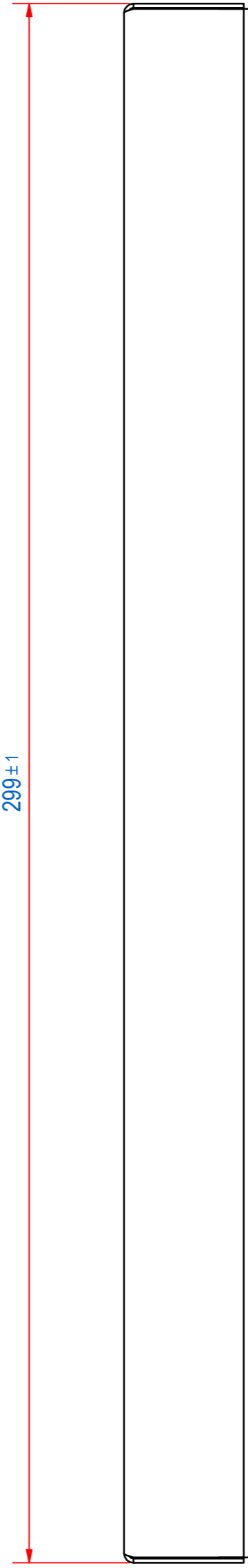
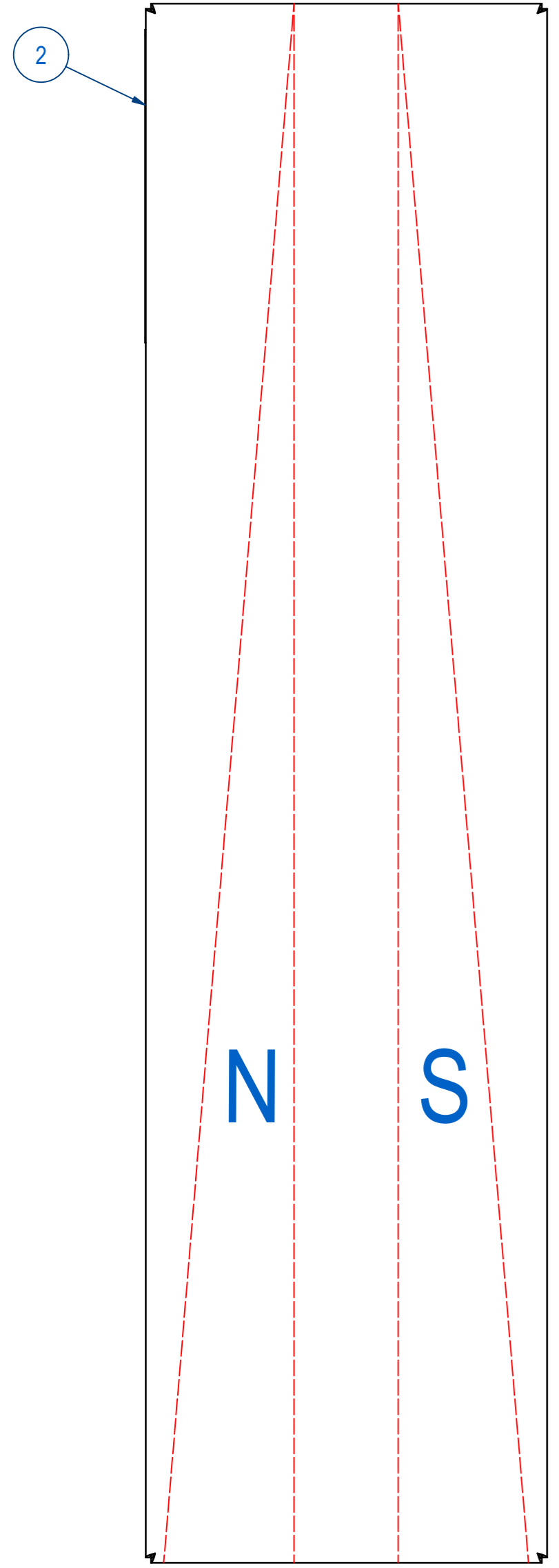

ITEM	QTY	PART NUMBER	DESCRIPTION	Dimensions
2	1	E0156615	HRA-TYPE PLATE STICKER	
1	1	E0155233	HRA-WELD ASSY	

RAW MAT.	Quantity	Material Number	Material Description	Length (mm)	Width (mm)
	1				

Sheet:	A2	Extra info:	General tolerance:	ISO 2768- mK
Drawn:	BS	Weight (kg):	Drawn according:	ISO268; ISO1101; ISO2553
Date:	20-5-2014		Status:	Standard
Spare part:	False	Source:	Customer reference number:	
Quick search:	TBAC02		Document number:	TBAC030002
Description:	HRA-F-077x24-AC-0300-B-B		Doc.Rev:	C
			Part number:	TBAC030002
			Rev:	C