

REV	DATE	BY	DESCRIPTION
-	22-5-2014	BS	NEW VAULT, NOTHING CHANGED, IS EQUAL TO OLD REVISION C
A	8-7-2022	PB	WELD ASSY ADDED
B	18-1-2023	DK	SOURCE CODE ADDED, STICKER ADDED TO BOM

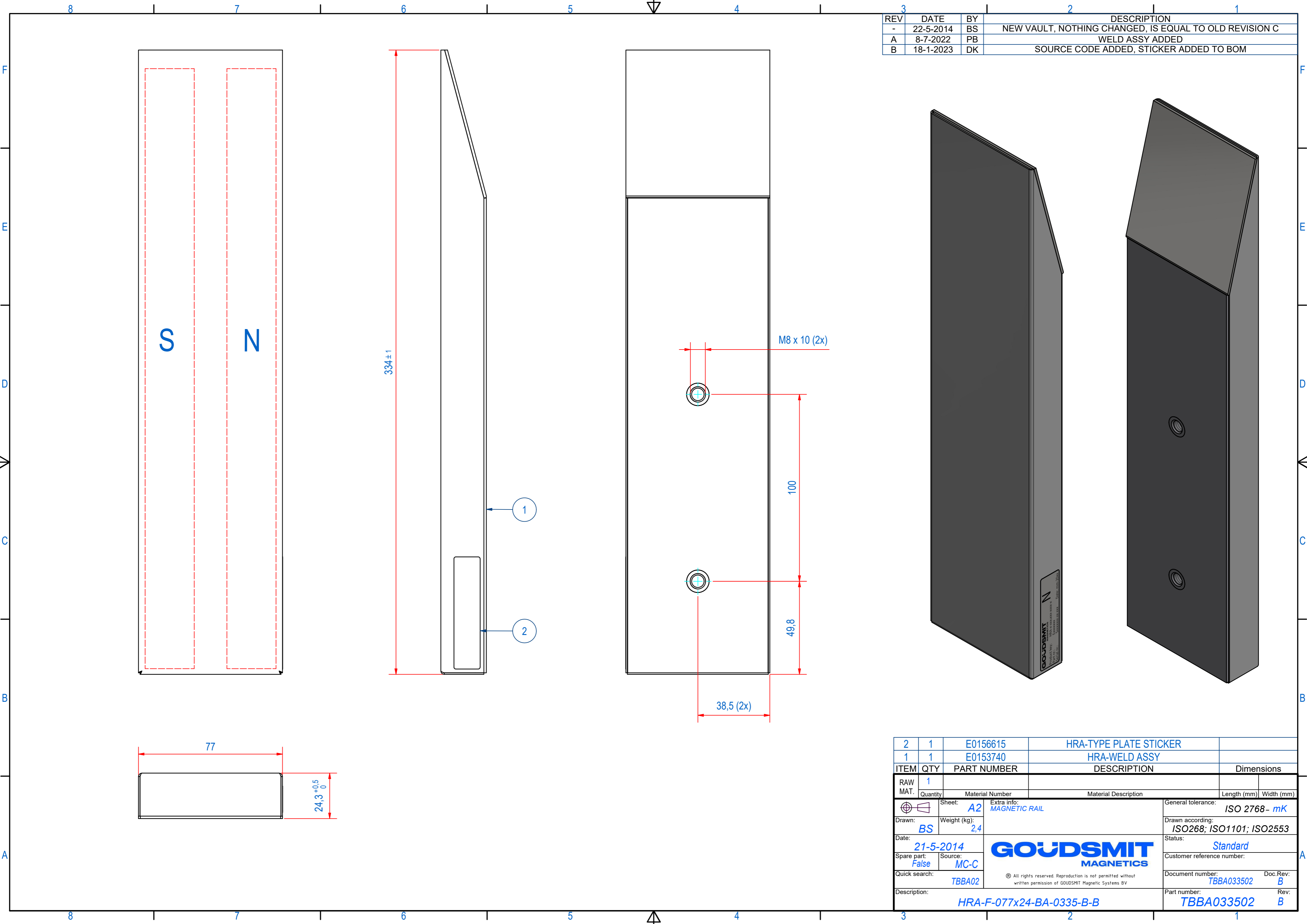

ITEM	QTY	PART NUMBER	DESCRIPTION	Dimensions
2	1	E0156615	HRA-TYPE PLATE STICKER	
1	1	E0153740	HRA-WELD ASSY	

RAW MAT.	Quantity	Material Number	Material Description	Length (mm)	Width (mm)
	1				

Sheet: <b>A2</b>	Extra info: <b>MAGNETIC RAIL</b>	General tolerance: <b>ISO 2768- mK</b>
Drawn: <b>BS</b>	Weight (kg): <b>2,4</b>	Drawn according: <b>ISO268; ISO1101; ISO2553</b>
Date: <b>21-5-2014</b>	Source: <b>MC-C</b>	Status: <b>Standard</b>
Spare part: <b>False</b>	Quick search: <b>TBBA02</b>	Customer reference number:
Description: <b>HRA-F-077x24-BA-0335-B-B</b>		Document number: <b>TBBA033502</b> Doc.Rev: <b>B</b>
		Part number: <b>TBBA033502</b> Rev: <b>B</b>