

| REV | DATE | BY | DESCRIPTION |
|-----|-----------|----|---|
| - | 8-7-2014 | BS | NEW VAULT, NEW REVISION. NOTHING CHANGED. OLD REV WAS D |
| A | 18-1-2023 | DK | SOURCE CODE AND TYPE PLATE STICKER ADDED |

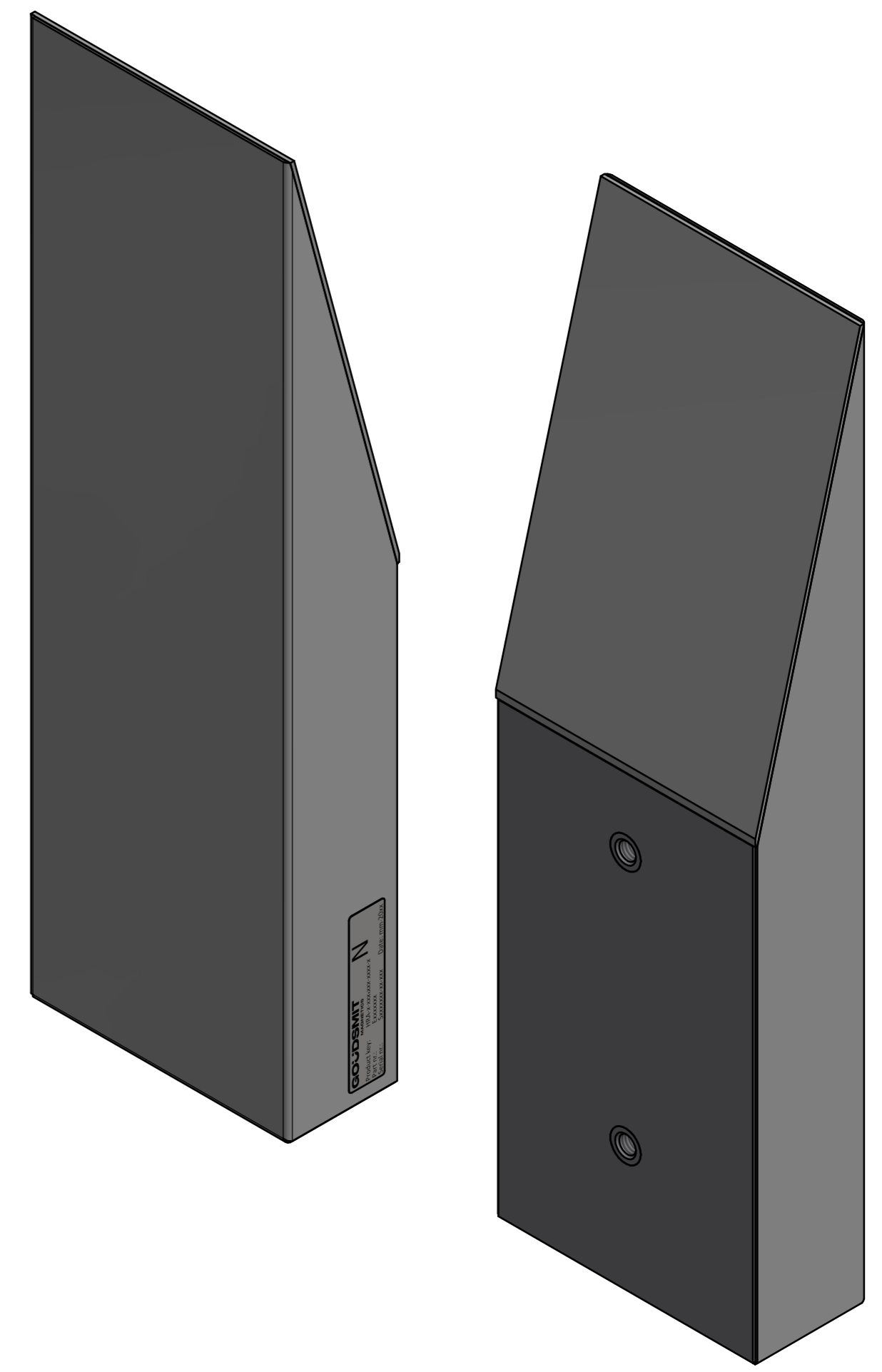
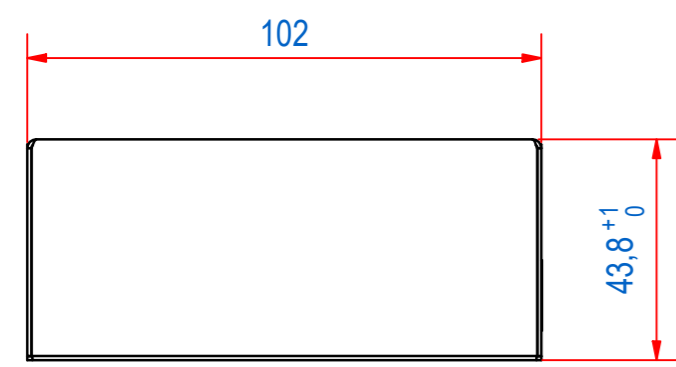
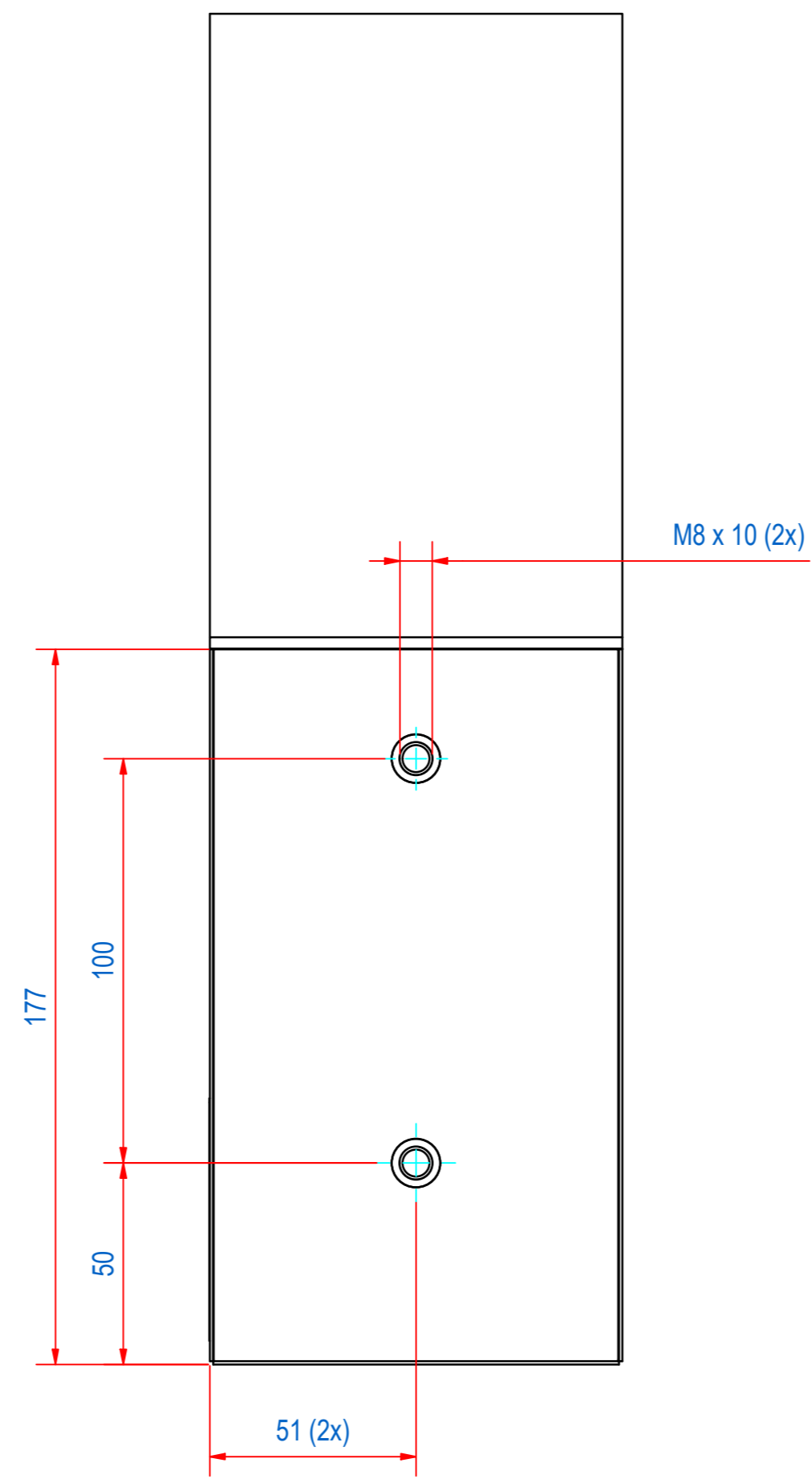
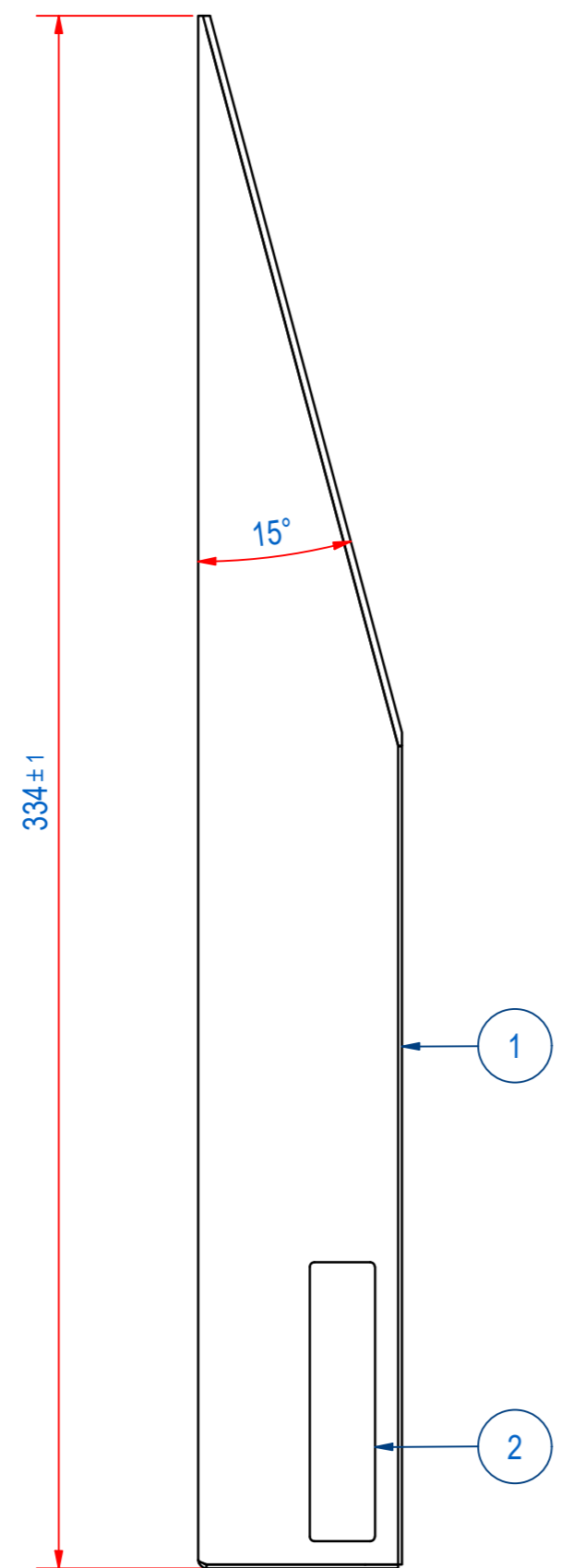
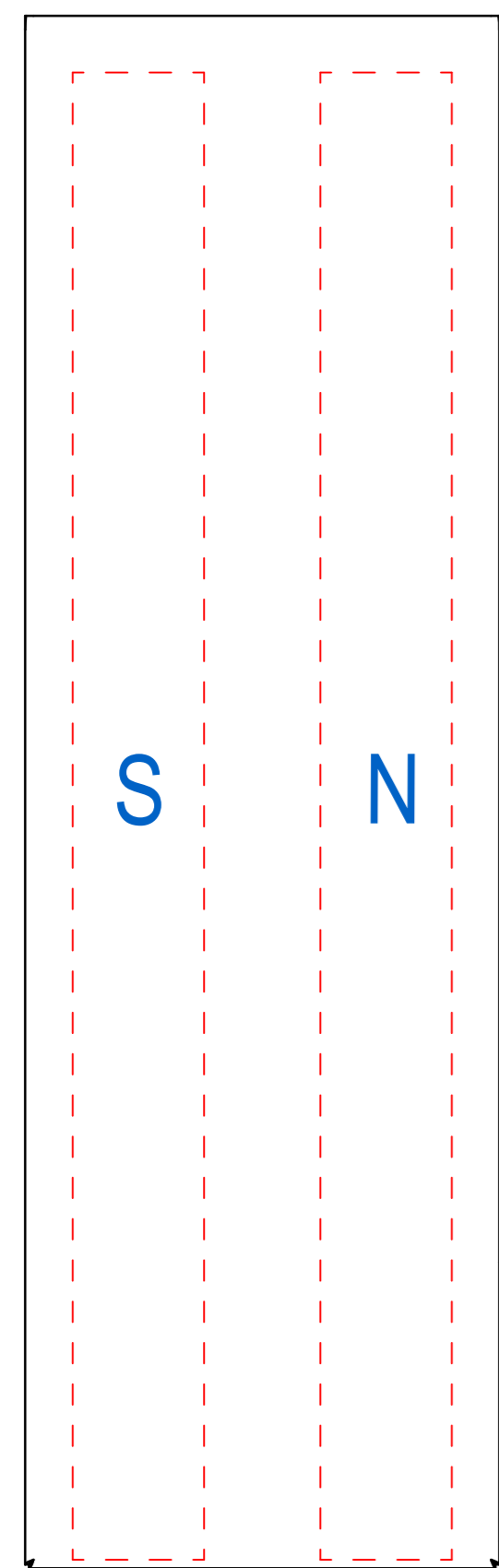

| ITEM | QTY | PART NUMBER | DESCRIPTION | Dimensions |
|------|-----|-------------|------------------------|------------|
| 2 | 1 | E0156615 | HRA-TYPE PLATE STICKER | |
| 1 | 1 | E0157302 | HRA-WELD ASSY | |

| RAW MAT. | Quantity | Material Number | Material Description | Length (mm) | Width (mm) |
|----------|----------|-----------------|----------------------|-------------|------------|
| | 1 | | | | |

| | | | | | |
|-------------|----------|--------------|---------------|----------------------------|--------------------------|
| Sheet: | A2 | Extra info: | MAGNETIC RAIL | General tolerance: | ISO 2768- mK |
| Drawn: | BS | Weight (kg): | 4,4 | Drawn according: | ISO268; ISO1101; ISO2553 |
| Date: | 7-7-2014 | Status: | Standard | Customer reference number: | |
| Spare part: | False | Source: | MC-C | Document number: | TBBA033504 |
| Doc. Rev: | A | Doc. Rev: | A | Part number: | TBBA033504 |
| Rev: | A | Rev: | A | Description: | HRA-F-102x44-BA-0335-B-B |