

REV	DATE	BY	DESCRIPTION
-	8-10-2013	PB	NEW VAULT, NEW REVISION. NOTHING CHANGED. OLD REV WAS C
A	18-1-2023	DK	SOURCE CODE AND TYPE PLATE STICKER ADDED
B	2-2-2023	DK	VIEWS UPDATED

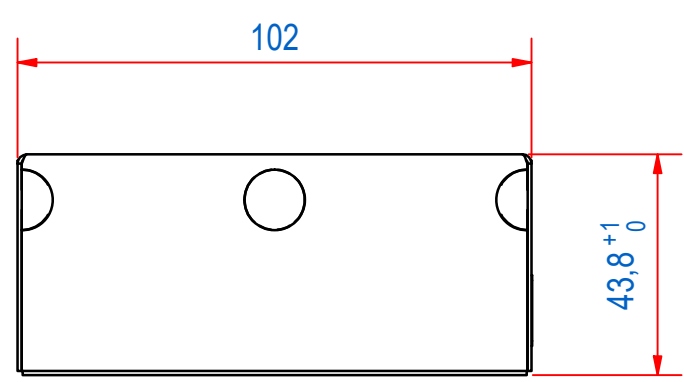
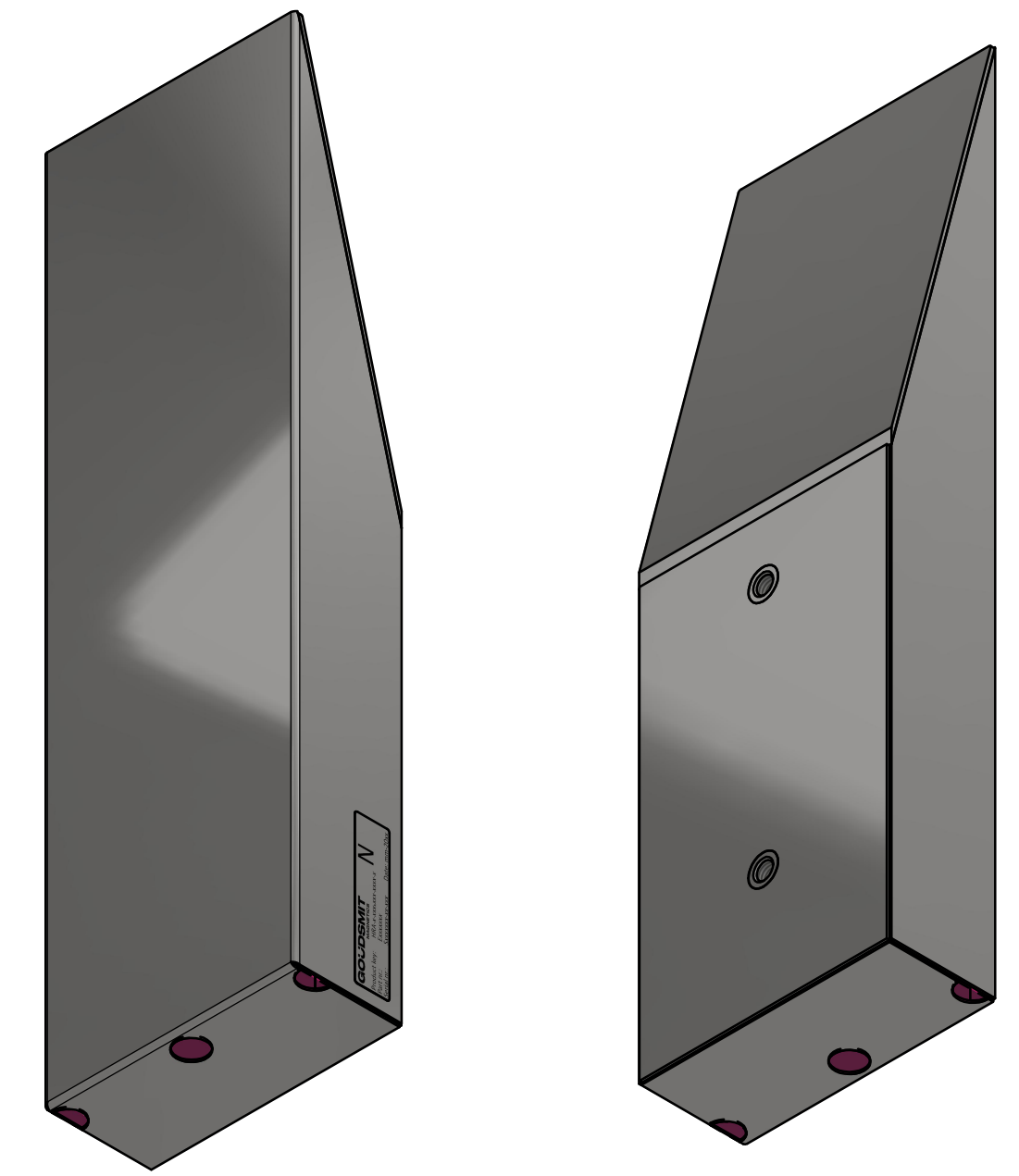
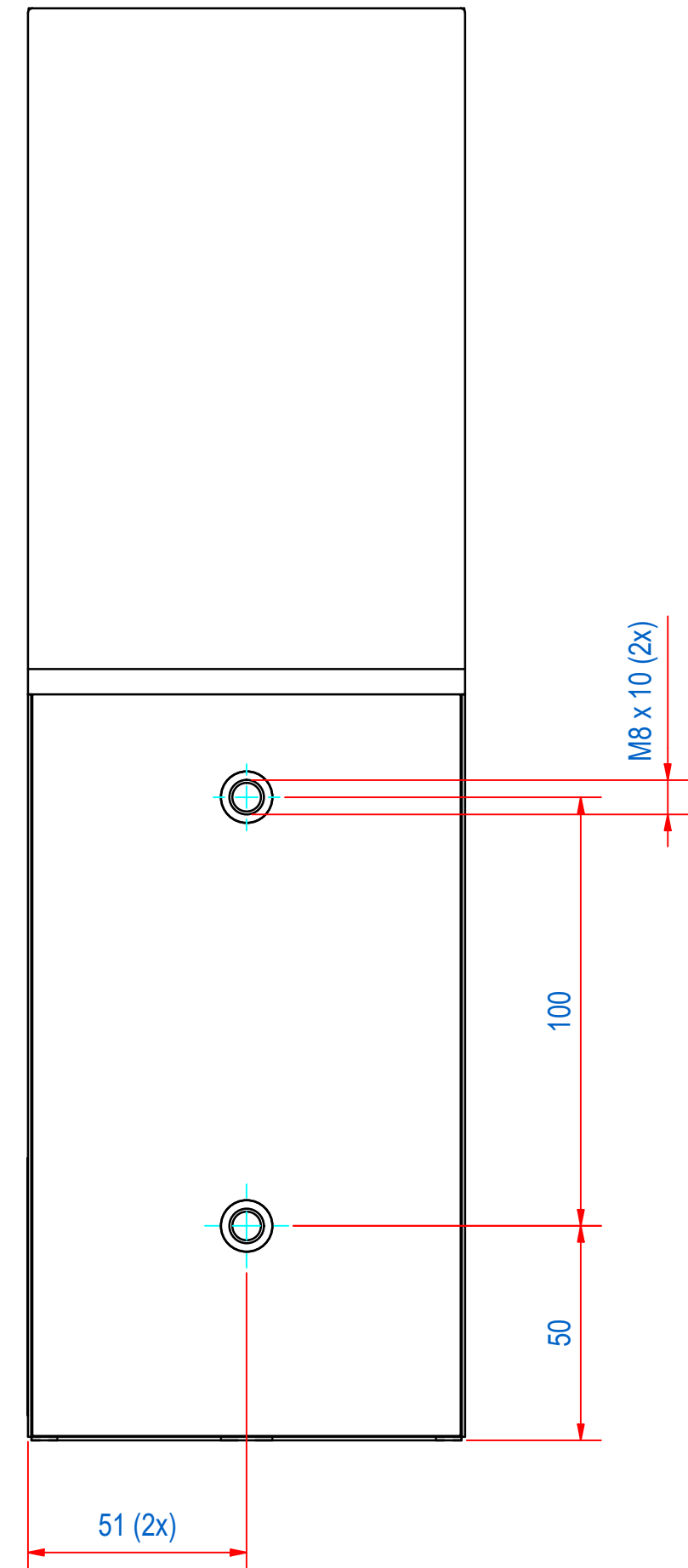
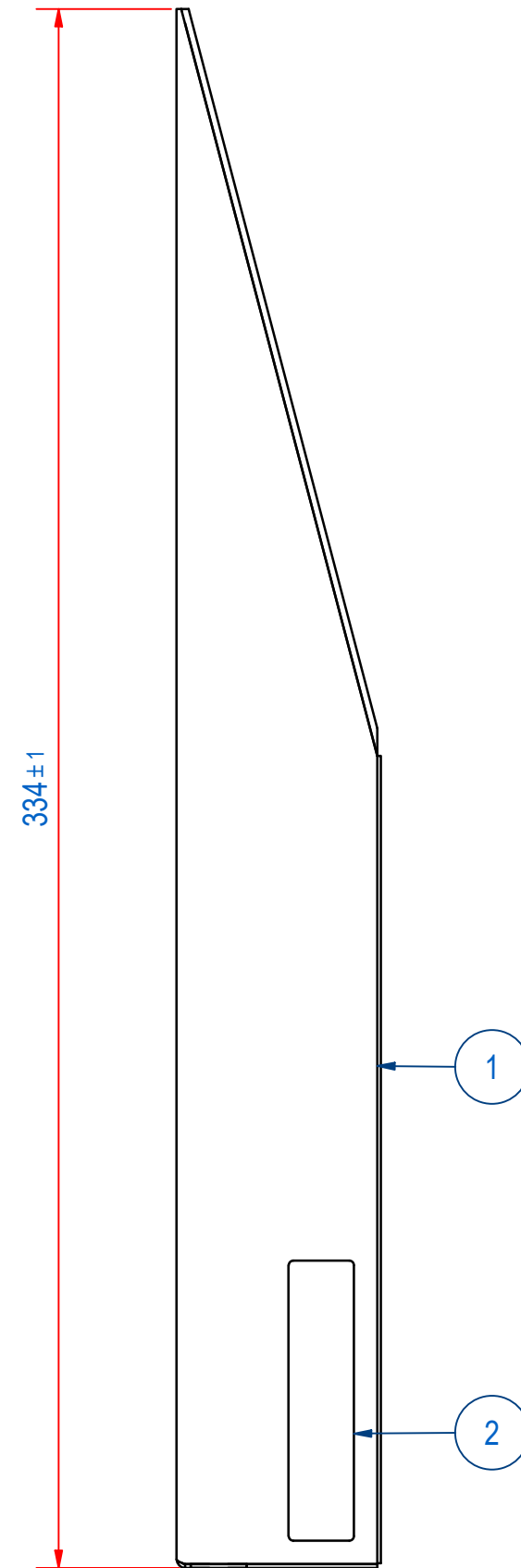
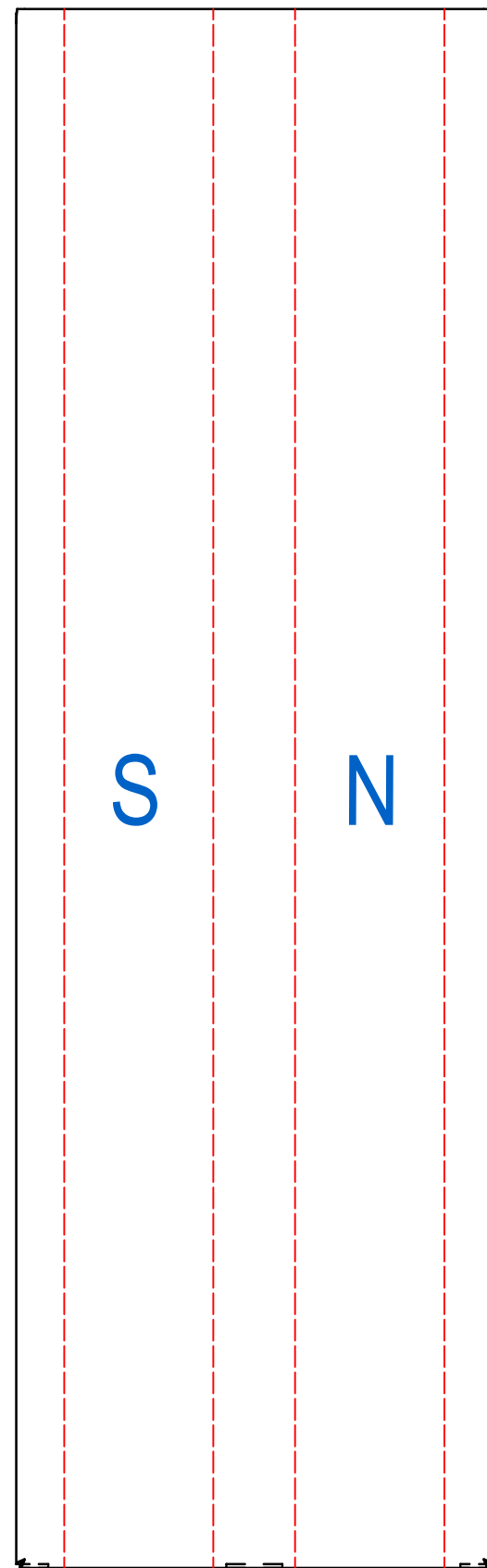

ITEM	QTY	PART NUMBER	DESCRIPTION	Dimensions
2	1	E0156683	HRA-TYPE PLATE ETCH	
1	1	E0157308	HRA-WELD AND MOULD ASSY	
RAW MAT.	Quantity	Material Number	Material Description	Length (mm) Width (mm)
	1			
Sheet:	A2		Extra info: MAGNETIC RAIL REINFORCED WATERTIGHT AISI	General tolerance: ISO 2768 - mK
Drawn:	PB		Weight (kg): 6,3	Drawn according: ISO268; ISO1101; ISO2553
Date:	8-10-2013			Status: Standard
Spare part:	False		Source: MC-C	Customer reference number:
Quick search:	TBBA54			Document number: TBBA033554 Doc.Rev: B
Description:	HRA-F-102x44-BA-0335-R-W			Part number: TBBA033554 Rev: B