

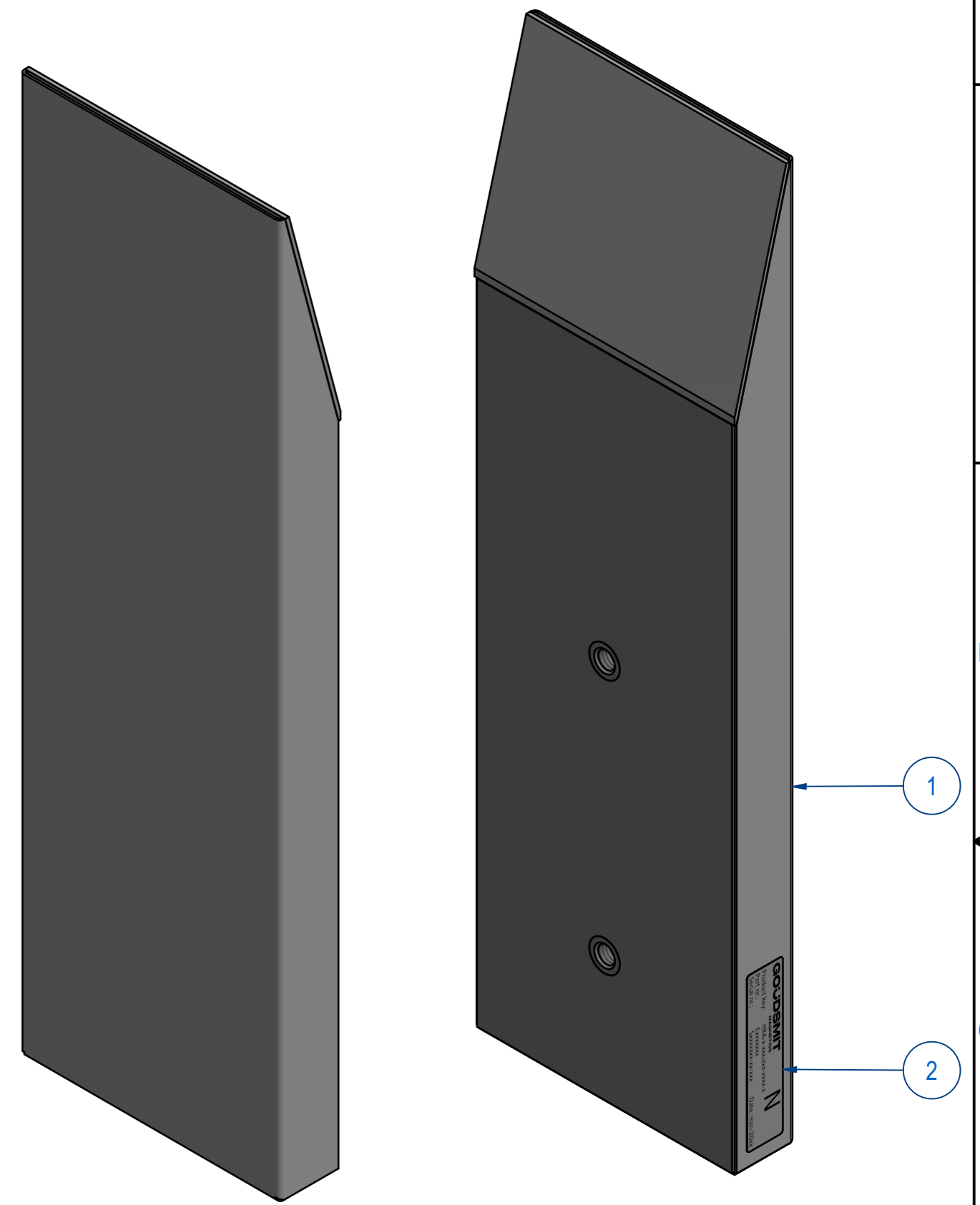

REV	DATE	BY	DESCRIPTION
-	7-7-2014	BS	ORIGINAL DRAWING
A	18-1-2018	PB	POLE DIRECTION CHANGED
B	18-1-2023	DK	SOURCE CODE AND STICKER ADDED TO BOM

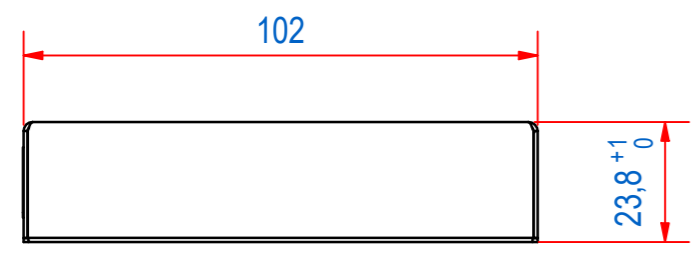
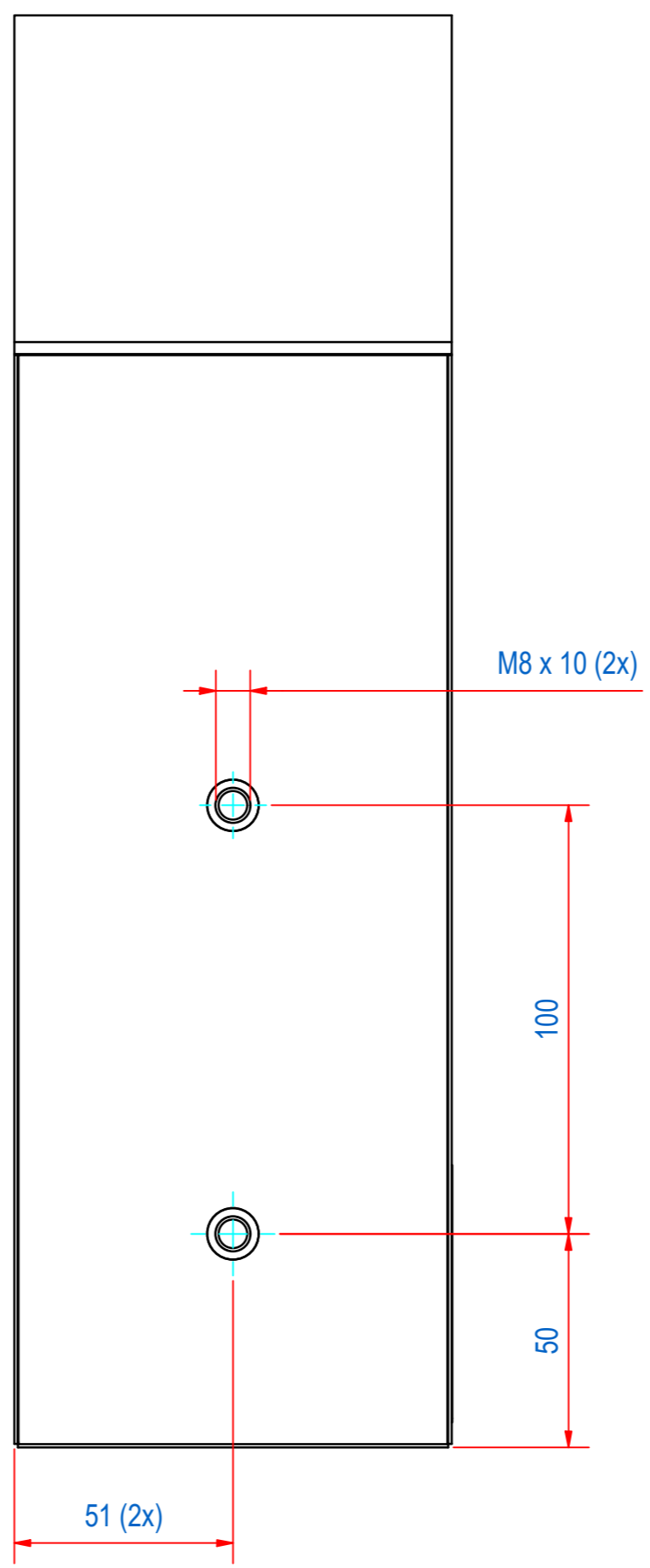
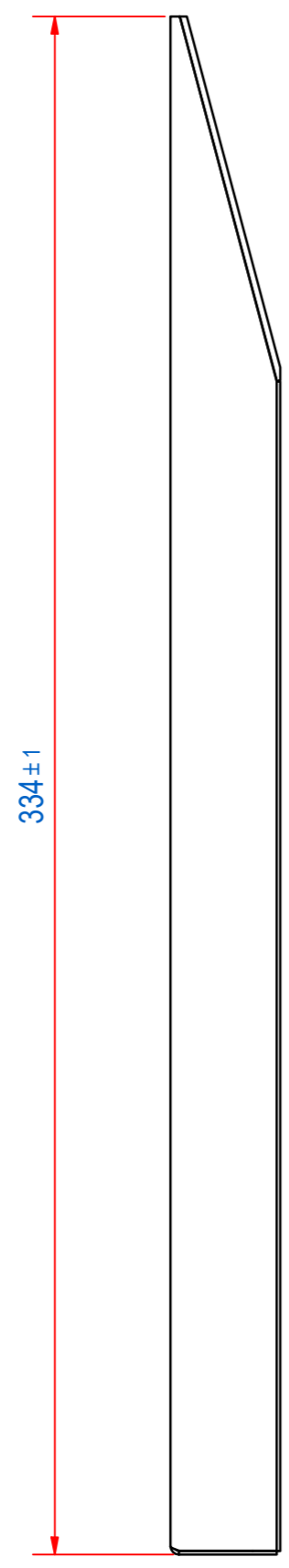
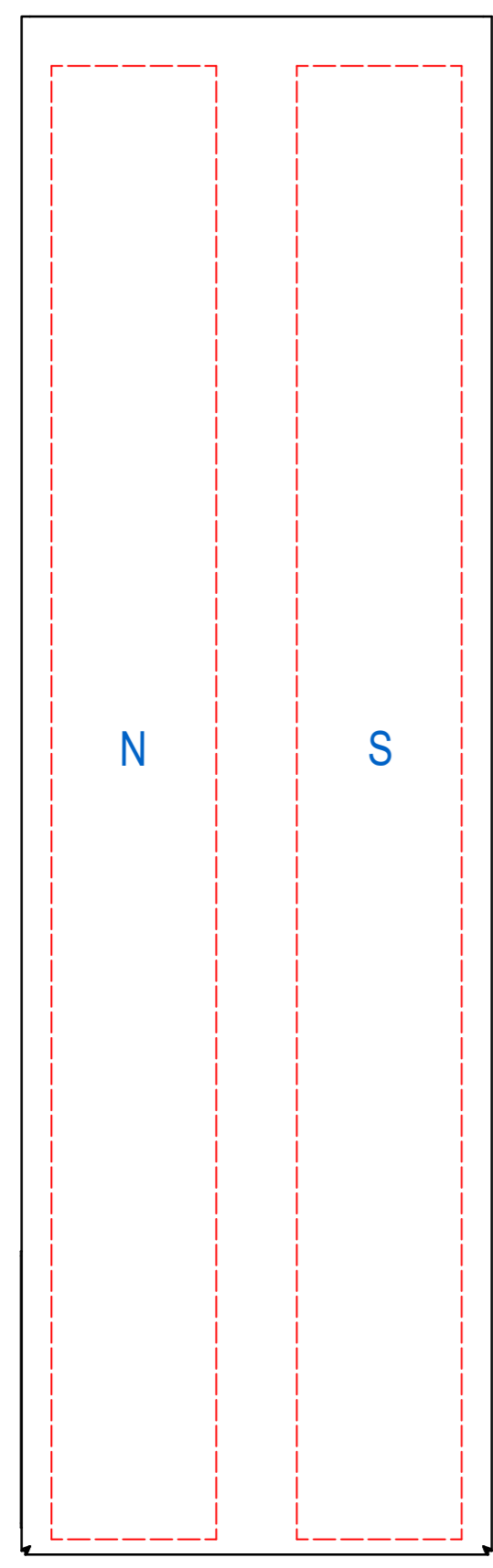

ITEM	QTY	PART NUMBER	DESCRIPTION	Dimensions
2	1	E0156615	HRA-TYPE PLATE STICKER	
1	1	E0157379	HRA-WELD ASSY	
RAW MAT.	1			
Quantity		Material Number	Material Description	Length (mm) Width (mm)
Sheet:	A2	Extra info:	MAGNETIC RAIL	General tolerance: ISO 2768- mK
Drawn:	PB	Weight (kg):	3,2	Drawn according: ISO268; ISO1101; ISO2553
Date:	2-3-1999	Status:	Standard	Customer reference number:
Spare part:	False	Source:	MC-C	Document number: TBBB033503 Doc.Rev: B
Quick search:	TBBB03	 <small>© All rights reserved. Reproduction is not permitted without written permission of GOUDSMIT Magnetic Systems BV</small>		Part number: TBBB033503 Rev: B
Description:	HRA-F-102x24-BB-0335-B-B			