

REV	DATE	BY	DESCRIPTION
-	17-12-2014	AvD	NEW VAULT, NEW REVISION. NOTHING CHANGED. OLD REV WAS B
A	18-1-2023	DK	SOURCE CODE AND TYPE PLATE STICKER

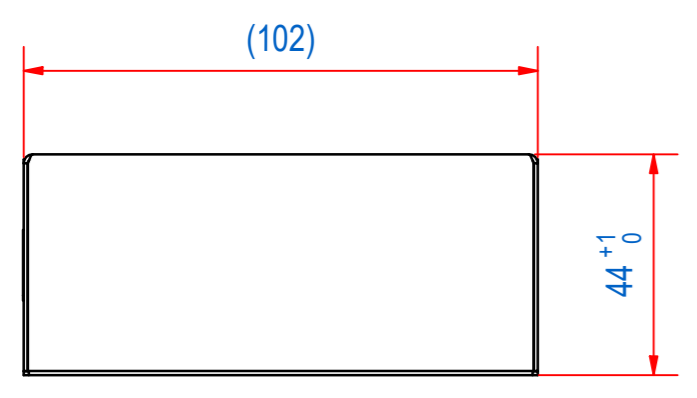
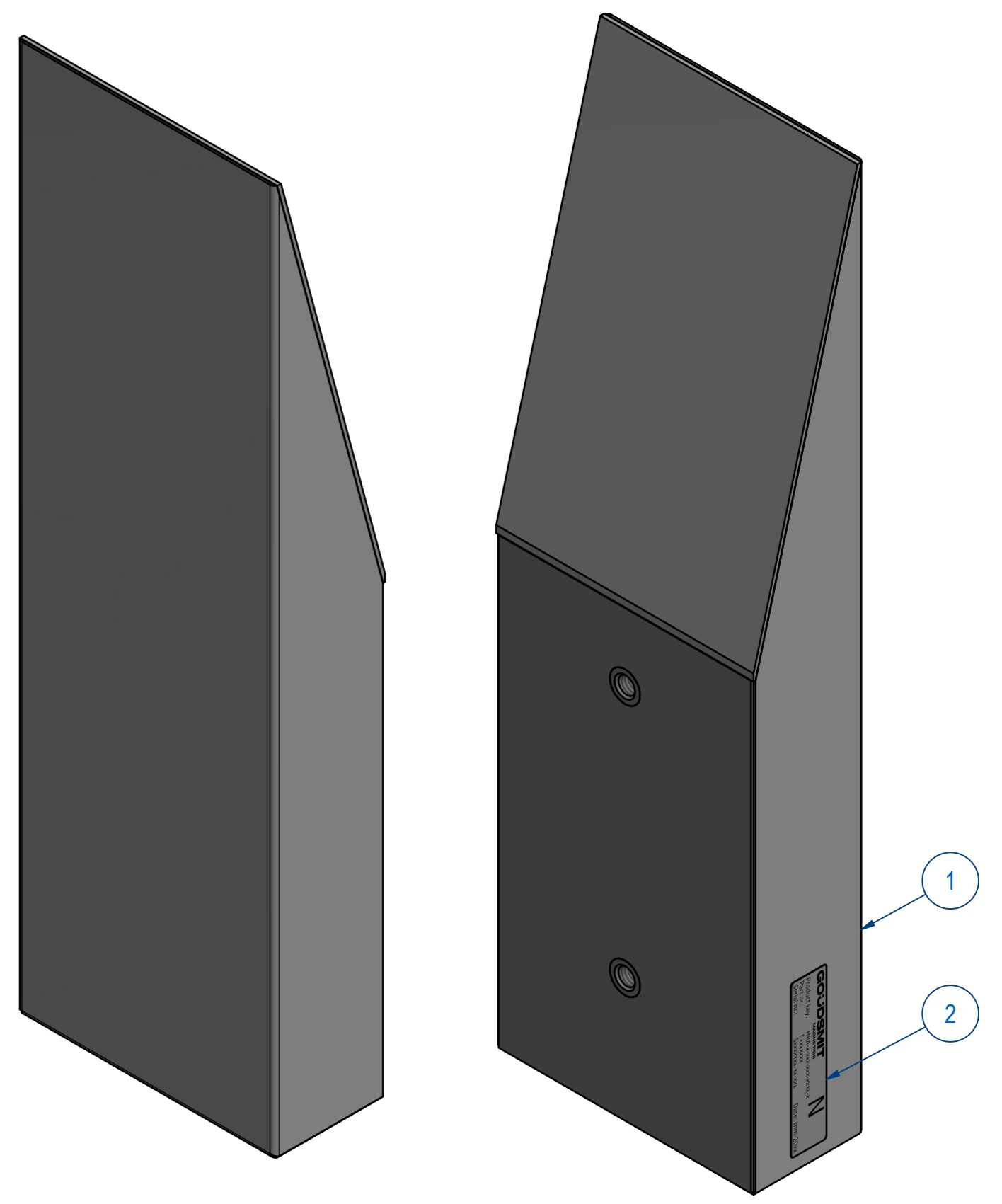
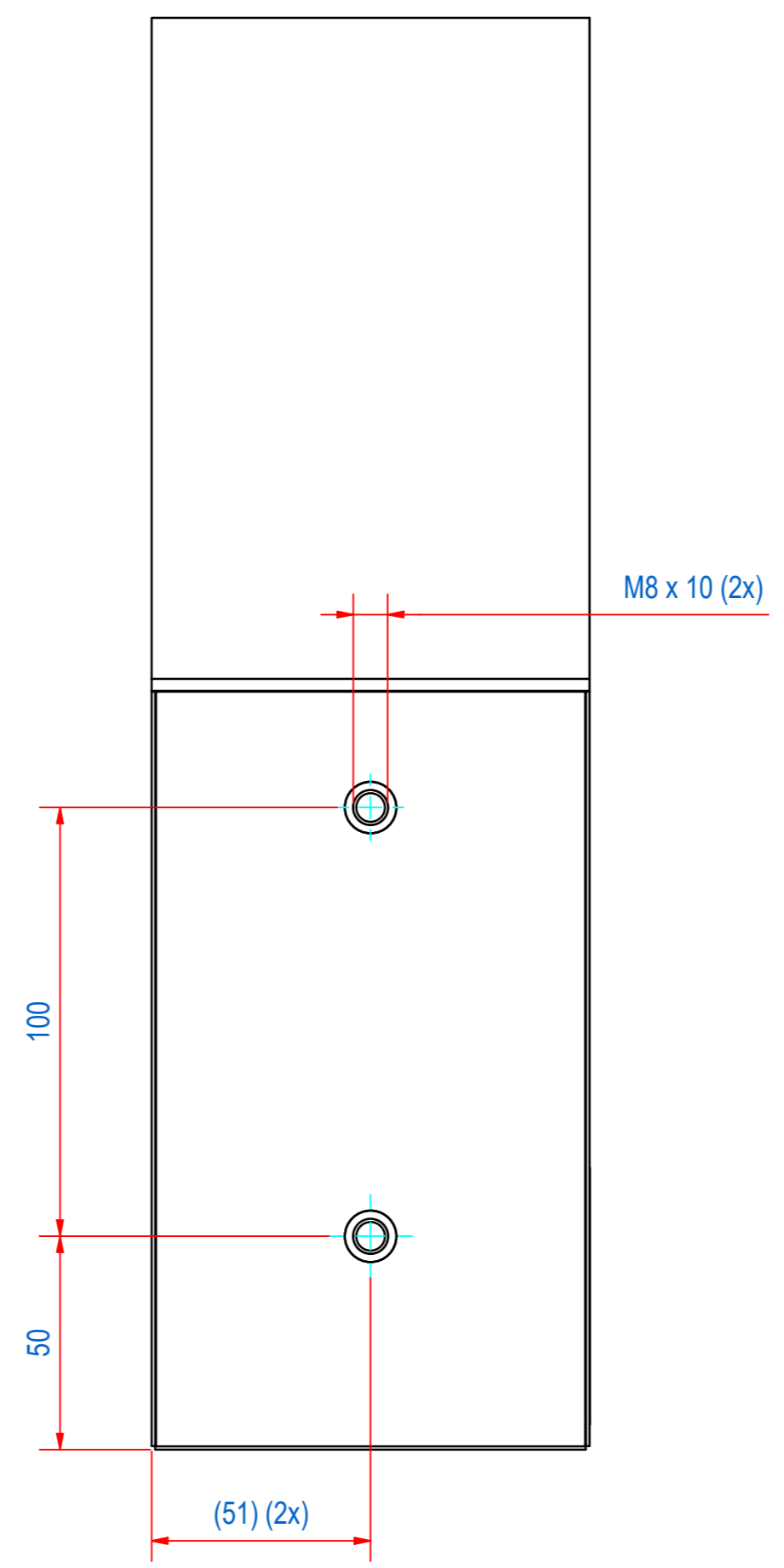
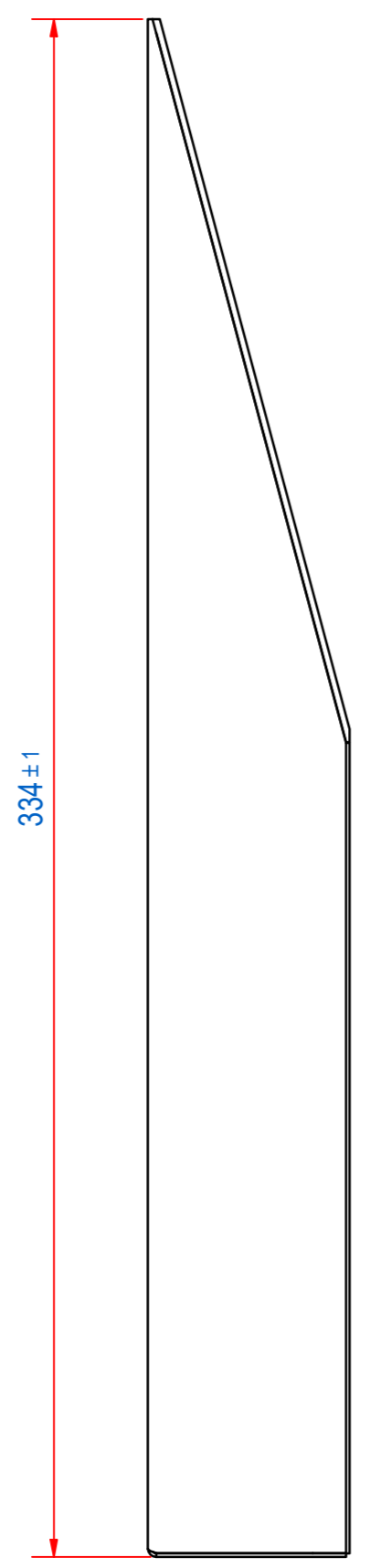
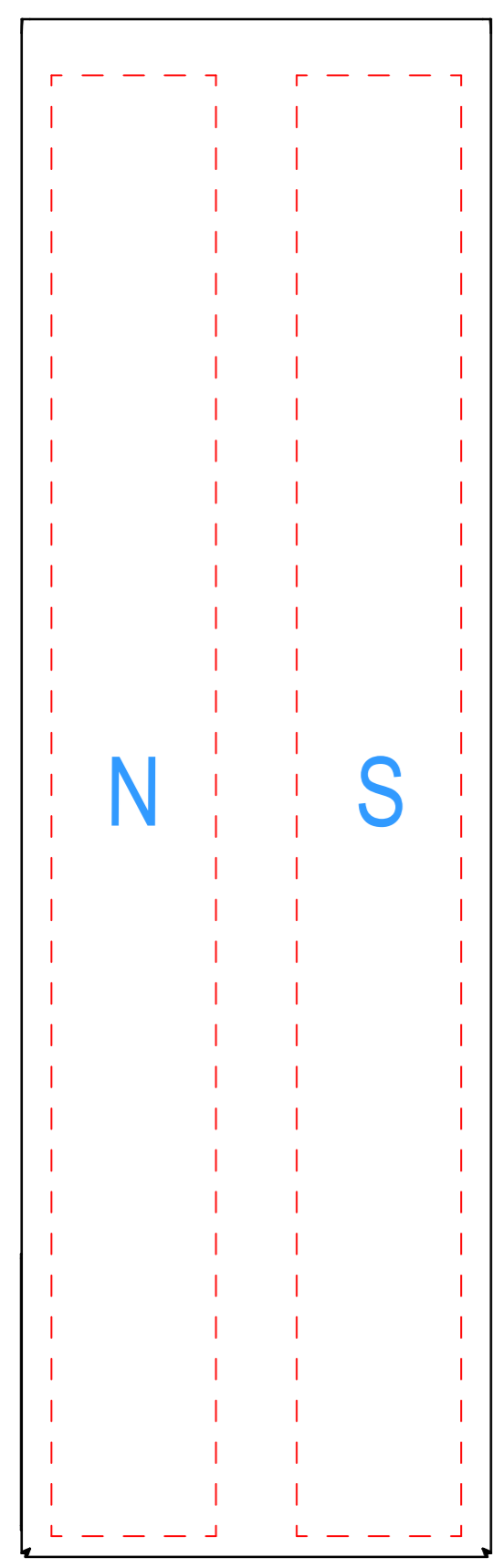

ITEM	QTY	PART NUMBER	DESCRIPTION	Dimensions
2	1	E0156615	HRA-TYPE PLATE STICKER	
1	1	E0157383	HRA-WELD ASSY	
RAW MAT.	1			
Quantity		Material Number	Material Description	Length (mm) Width (mm)
Sheet:	A2	Extra info:	MAGNETIC RAIL	General tolerance: ISO 2768- mK
Drawn:	BS	Weight (kg):	4,4	Drawn according: ISO268; ISO1101; ISO2553
Date:	8-7-2014	Status:	Standard	
Spare part:	False	Source:	MC-C	Customer reference number:
Quick search:	TBBB04			Document number: TBBB033504 Doc.Rev: A
Description:	HRA-F-102x44-BB-0335-B-B			Part number: TBBB033504 Rev: A